

## 2-Wire Surveillance Kit PMLN6225



68012009007-DB

MOTOROLA, MOTO, MOTOROLA SOLUTIONS and the Stylized M logo are trademarks or registered trademarks of Motorola Trademark Holdings, LLC and are used under license. All other trademarks are the property of their respective owners.  
© 2013 and 2021 Motorola Solutions, Inc.  
All rights reserved.  
Printed in



- Turn down the volume before connecting headset or ear piece.
- Limit the amount of time you use headsets or earpieces at high volume.
- When using the radio without a headset or ear piece, do not place the radio's speaker directly against your ear.

### DESCRIPTION

The PMLN6225 is a two-wire surveillance style accessory with one wire for listening through an acoustic tube and another separate wire for transmitting using an integrated microphone/PTT housing. The Clear Acoustic Tube snaps on to the earbud part of the kit for enhanced discrete communication. The integrated microphone/PTT comes with a clothes clip allowing you to wear it under your uniform for more discreet covert operations, yet giving the flexibility of hands-free communication.

**NOTE:** It is the user's responsibility to ensure that the chosen accessory is suitable for his/her intended use.

### FOREWORD

#### RF Energy Exposure and Product Safety Guide for Portable Two-Way Radios

#### ATTENTION!

Before using this product, read the RF Energy Exposure and Product Safety Guide that ships with the radio which contains instructions for safe usage and RF energy awareness and control for compliance with applicable standards and regulation.

### ACOUSTIC SAFETY

Exposure to loud noises from any source for extended periods of time may temporarily or permanently affect your hearing. The louder the radio's volume, the less time is required before your hearing could be affected. Hearing damage from loud noise is sometimes undetectable at first and can have a cumulative effect.

To protect your hearing:

- Use the lowest volume necessary to do your job.
- Turn up the volume only if you are in noisy surroundings.

### OPERATION

#### Attaching and Removing the Surveillance Accessory to the Radio

1. Always turn the radio OFF before connecting the accessory.
2. Firmly plug the accessory connector into the radio side and secure the connector as shown in Figure 1.

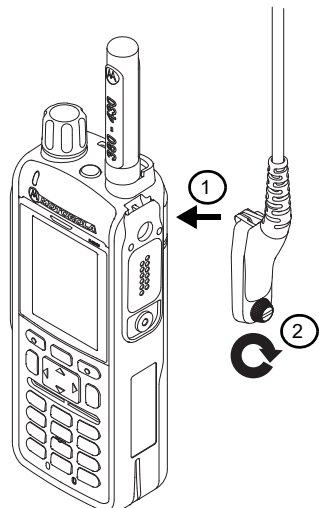
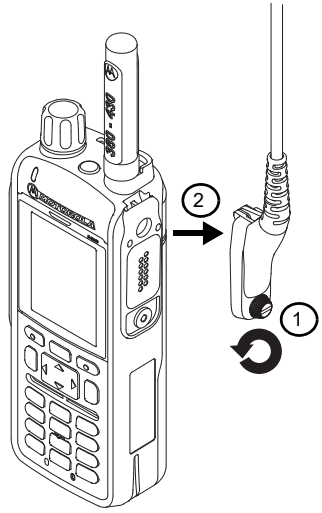

**Figure 1:** Securing the accessory connector

3. Turn the radio ON - make sure you do not set the volume level too high.

**NOTE:** Once the accessory is connected, the radio microphone and speaker are disabled.

4. Place the accessory in the ear.
5. Adjust the volume on the radio to a comfortable listening level.
6. Press the Push-to-Talk (PTT) button, and speak into microphone to confirm that the two-way communication works (the radio-in-transmission light (LED) will be illuminated).
7. To receive information, release the button.
8. Always turn your radio OFF before disconnecting the accessory.
9. Remove the accessory connector as shown in Figure 2.



**Figure 2:** Removing the accessory connector

## SERVICE

The replacement shown in Table 1 is available for the PMLN6225. Please contact your local Motorola Solutions Representative or Dealer for details.

**Table 1. Replacement Part**

Part Description	Part Number
Clear Acoustic Tube Ear piece, Assembly	HKLN4478

## NOTES