

# IMPRES™ 2 MULTI-UNIT CHARGER

## USER GUIDE



en-US

fr-CA

es-LA

pt-BR

zh-CN

ko-KR

de-DE

fr-FR

it-IT

nl-NL

uk-UA



**MOTOROLA SOLUTIONS**



## **FCC Notices**

This equipment has been tested and found to comply with the limits for a Class A digital device, pursuant to part 15 of the FCC Rules. These limits are designed to provide reasonable protection against harmful interference when the equipment is operated in a commercial environment.

This equipment generates, uses, and can radiate radio frequency energy and, if not installed and used in accordance with the instruction manual, may cause harmful interference to radio communications. Operation of this equipment in a residential area is likely to cause harmful interference in which case the user will be required to correct the interference at his own expense.

### **Avis FCC**

Cet équipement a fait l'objet de tests et a été déclaré conforme aux limites établies pour un appareil numérique de classe A, conformément à la section 15 des règlements de la FCC. Ces limites sont conçues pour offrir une protection raisonnable contre les interférences nuisibles lorsque l'équipement est utilisé dans un environnement commercial.

Cet appareil produit, utilise et peut rayonner une énergie sous la forme de radiofréquences et, s'il n'est pas installé et employé en conformité avec les instructions du manuel, il peut provoquer des interférences nuisibles au niveau des communications radios. L'utilisation de cet équipement dans un environnement résidentiel est susceptible de provoquer des interférences nuisibles, auquel cas l'utilisateur devra les corriger à ses propres frais.

# IMPORTANT SAFETY INSTRUCTIONS

## Save These Instructions

This document contains important safety and operating instructions. Please read these instructions carefully and save them for future reference.

Before using the battery charger, read all the instructions and cautionary markings on (1) the charger, (2) the battery, and (3) the radio using the battery.



**WARNING**

1. To reduce risk of damage to the power cord, pull the plug rather than the cord when disconnecting from the AC outlet or the charger.
2. An extension cord should not be used unless absolutely necessary. Use of an improper extension cord could result in risk of fire and electric shock. If an extension cord must be used, make sure that the cord size is 18 AWG for lengths of up to 6.5 feet (2.0 m), and 16 AWG for lengths up to 9.8 feet (3.0 m).
3. To reduce risk of fire, electric shock, or injury, do not operate the charger if it has been broken or damaged in any way. Take it to a qualified Motorola Solutions service representative.
4. Do not disassemble the charger. Disassembling the charger may result in risk of electric shock or fire. The only repairable/ replacement parts are the NNTN9212 and NNTN9213 Pocket Inserts. Follow the instructions in APX-Series IMPRES 2 Multi-Unit Charger Pocket Insert Kits MN005697A01.
5. To reduce risk of electric shock, unplug the charger power supply from the AC outlet before attempting any maintenance or cleaning.
6. To reduce risk of injury, charge only the rechargeable Motorola Solutions authorized batteries listed in Table 2. Other batteries may explode, causing personal injury and damage.
7. Use of accessories not recommended by Motorola Solutions may result in risk of fire, electric shock, or injury.

## Operational Safety Guidelines

- This equipment is not suitable for outdoor use. Use only in dry locations and conditions.
- Maximum ambient temperature around the charger must not exceed 40 °C (104 °F).
- While a radio is in a charger pocket, the radio may be turned ON only if the radio is transmitting data wirelessly, such as using Wi-Fi. Otherwise, turn OFF the radio.
- Connect the charger only to an appropriate power supply as listed in Table 3.
- The AC outlet to which the power cord is connected must be close and easily accessible.
- Make sure the power supply cord connected to the charger is located where it cannot be stepped on, tripped over, or subjected to water, damage, or stress.
- Connect the power cord only to an appropriately fused and wired AC outlet with the correct voltage, as specified on the product.
- Disconnect from line voltage by removing the power cord from the AC outlet.
- Connect no more than the appropriate number of chargers to a 15 A or 20 A circuit, as limited by any certified power strip being used. Daisy chaining power strips is NOT RECOMMENDED. Limit circuit loading below 80 % of the circuit rating.
- Use only Motorola Solutions Authorized Pockets.

## Supported Models

**Table 1: Supported Models and Description**

Model	Description
PS000029A01 (UNIV) PS000029A04 (EU/UK) PS000029A06 (RK)	APX 1-Display IMPRES 2 Multi-Unit Charger with Charger Reprogramming and Fleet Management
PS000029A02 (UNIV) PS000029A05 (EU/UK) PS000029A07 (RK)	APX 6-Display IMPRES 2 Multi-Unit Charger with Charger Reprogramming and Fleet Management
PS000029A03 (EU/UK) PS000029A08 (RK)	APX 6-Display IMPRES 2 Multi-Unit Charger with Charger Reprogramming, Fleet Management, and USB Accessory Charging
PS000337A01 (US/NA/ AU/NZ)	APX NEXT 6-Display IMPRES 2 Multi-Unit Charger with Charger Reprogramming and Fleet Management

## Motorola Solutions Authorized Batteries

The APX-Series IMPRES 2 Chargers charge the batteries listed in Table 2. The batteries may be attached to a radio or may be stand-alone.

**Table 2: Motorola Solutions Authorized Batteries.**

Kit (PN)	Description
NNTN7033	IMPRES Li-Ion FM (HazLoc) IP67 4100 mAh
NNTN7034	IMPRES Li-Ion IP67 4200 mAh
NNTN7035	IMPRES NiMH FM (HazLoc) Ruggedized 2000 mAh
NNTN7036	IMPRES NiMH FM (HazLoc) IP67 2000 mAh
NNTN7037	IMPRES NiMH IP67 2100 mAh
NNTN7038	IMPRES Li-Ion IP67 2900 mAh
NNTN7573	IMPRES NiMH Ruggedized 2100 mAh
NNTN8092	IMPRES Li-Ion FM (HazLoc) Ruggedized 2300 mAh
NNTN8182	IMPRES Li-Ion Ruggedized 2900 mAh
NNTN8921	IMPRES 2 Li-Ion TIA4950 (HazLoc) Ruggedized IP67 3700 mAh
NNTN8930	IMPRES 2 Li-Ion TIA4950 (HazLoc) Ruggedized IP67 2700 mAh
NNTN9087	IMPRES 2 Li-Ion IP68 3800 mAh

**Table 2: Motorola Solutions Authorized Batteries.**

Kit (PN)	Description
NNTN9088	IMPRES 2 Li-Ion DIVISION 2 (HazLoc) IP68 3800 mAh
NNTN9089	IMPRES 2 Li-Ion IP68 5650 mAh
NNTN9090	IMPRES 2 Li-Ion DIVISION 2 (HazLoc) IP68 5650 mAh
NNTN9126	IMPRES 2 Li-Ion IP68 4400 mAh
NNTN9127	IMPRES 2 Li-Ion DIVISION 2 (HazLoc) IP68 4400 mAh
PMNN4403	IMPRES Li-Ion IP67 2150 mAh
PMNN4485	IMPRES 2 Li-Ion Ruggedized IP67 2500 mAh
PMNN4486	IMPRES 2 Li-Ion Ruggedized IP67 3400 mAh
PMNN4487	IMPRES 2 Li-Ion Ruggedized IP67 4400 mAh
PMNN4494	IMPRES 2 Li-Ion Ruggedized IP67 5000 mAh
PMNN4504	IMPRES 2 Li-Ion DIVISION 2 (HazLoc) Ruggedized IP67 3400 mAh
PMNN4505	IMPRES 2 Li-Ion DIVISION 2 (HazLoc) Ruggedized IP67 4850 mAh
PMNN4547	IMPRES 2 Li-Ion TIA4950 (HazLoc) Ruggedized IP68 3100 mAh
PMNN4573	IMPRES 2 Li-Ion TIA4950 (HazLoc) Ruggedized IP68 4600 mAh
PMNN4812	APX NEXT XN IMPRES 2 Li-Ion DIV 2 (HAZLOC) IP68 3400 mAh

## Motorola Solutions Authorized Power Supplies

**Table 3: Motorola Solutions Authorized Power Supplies**

Kit (PN)	Description
3087791G01	Power Cord, US/NA
3087791G04	Power Cord, EU
3087791G07	Power Cord, UK/HK
3087791G10	Power Cord, AU/NZ
3087791G13	Power Cord, AR
3087791G16	Power Cord, KR
3087791G20	Power Cord, JP
3087791G22	Power Cord, BR
CB000460A01	Power Cord, CH

## Motorola Solutions Authorized Communications Modules

**Table 4:** Motorola Solutions Authorized Communications Modules

Kit (PN)	Description
AS000013A01	IMPRES 2 Charger Reprogramming and Battery Fleet Management Module
AS000012A02	IMPRES 2 Charger Reprogramming/Battery Fleet Management and Accessory Charging Module

### Charger, Pocket, and Communications Module

The APX-Series IMPRES 2™ Adaptive Charger System is a fully automated battery care system. The charger is equipped with the following features:

- Adaptive charging to accommodate a wide variety of battery types, including IMPRES 2, IMPRES™, and other authentic Motorola Solutions batteries.
- Pocket that accommodates either a stand-alone battery or a radio with attached battery.
- Red / Amber / Green LED indicating charger pocket status.
- Communications Module
  - Charger reprogramming
  - IMPRES 2 or IMPRES battery data upload to an IMPRES Battery Fleet Management System
  - (Optional) Six USB Type A charging ports, each with 0.5A for charging of a USB accessory
- Keypad Menu
  - Charger Setup
  - Battery Analysis
- Information Display on Pocket #1.
  - Optional displays on other pockets
- Preparation of a stand-alone IMPRES 2 or IMPRES battery for long-term storage or preparation of a stand-alone Motorola Solutions Lithium-Ion battery for shipment. DO NOT leave batteries in the charger after preparation for Long-Term Storage or Lithium-Ion Shipment is complete.



- Energy Efficiency Features
  - Compliant with the California Energy Commission appliance standards for small battery charging systems. The charger pockets automatically sleep, then wake to respond to user action or to service a battery in the pocket.
  - Compliant with the European Standby Current Limits (European Charger Kit). When Power Saver Mode is enabled, all charger pockets, except Pocket #1, turn off automatically when there is no activity for a period of time. Pressing any Keypad button turns these pockets back on.
- Higher-rate IMPRES 2 Lithium-Ion battery charging.
- Faster charging.
- Extended battery life cycle.

Operation of a radio while it is in the charger is not recommended.

During the charging process, radio operation may result in minimally reduced radio performance and extended battery charge time.

During Calibration/Reconditioning, the battery is fully discharged before being fully charged. As a result, the radio may shut down during the discharge phase. It is recommended that you calibrate the battery without the radio attached or with the attached radio turned off.

## **IMPRES 2 and IMPRES Batteries and Chargers**

### **Features and Benefits**

The IMPRES 2 energy solution is an advanced Tri-Chemistry energy system developed by Motorola Solutions. This system includes:

- IMPRES 2 and IMPRES Batteries
- IMPRES 2 Adaptive Charger
- IMPRES Radios

Charging IMPRES 2 or IMPRES batteries using an IMPRES 2 Adaptive Charger, which periodically calibrates or reconditions the battery, yields the following benefits:

- Extends battery cycle life.
- Measures battery capacity and determines the current battery state of charge, giving you an indication of effective use time.

- Monitors the IMPRES 2 or IMPRES battery usage pattern.
- Updates pattern information stored in the IMPRES 2 or IMPRES battery.
- Automatically performs Calibration/Reconditioning only as needed.
- Minimizes IMPRES 2 or IMPRES battery heating, regardless of how long the battery is left in the pocket.
- Periodically “tops off” a battery stored in the charger pocket, maintaining a high state of readiness for the user.
- Eliminates Nickel battery memory effect, eliminating the need to purchase special equipment or train personnel in tasks to maintain battery cycle life.

Using this unique patented system, there is no need to track and record IMPRES 2 or IMPRES battery use, conduct manual Calibration/Reconditioning, or remove batteries from chargers following completion of charge.

### **IMPRES 2 or IMPRES Battery Initialization**

For full IMPRES 2 or IMPRES functionality, a new IMPRES 2 or IMPRES battery must be initialized by the charger. The charger automatically detects the new IMPRES 2 or IMPRES battery, and automatically starts Initialization. Initialization is the first IMPRES battery Calibration/Reconditioning of an IMPRES 2 or IMPRES battery. This is a two-phase process. The first phase is Battery Discharge, indicated by a **Steady Amber** LED. The second phase is full charge, eventually indicated by a **Steady Green** LED. This process can take up to 12 hours or more to complete, depending on the state of charge and capacity of the battery. Interruption of either phase delays Initialization until the next charging opportunity.

### **IMPRES 2 or IMPRES Pocket-to-Pocket**

When charging IMPRES 2 or IMPRES batteries, the IMPRES 2 or IMPRES charger records charging information within the battery memory. If the IMPRES 2 or IMPRES battery is removed from one IMPRES 2 or IMPRES charger pocket and, within 30 minutes, inserted into another or the same IMPRES 2 or IMPRES charger pocket, then charging resumes at the point where charging was interrupted. This

feature prevents battery over-charging and minimizes the loss of cycle life. This is especially important when charging Nickel batteries.

## Automatic IMPRES 2 or IMPRES Battery Calibration / Reconditioning

The IMPRES 2 charger automatically assesses the condition of an IMPRES 2 or IMPRES battery. Based on this condition, the charger automatically calibrates / reconditions the battery. Interruption of either the discharge phase or the full charge phase delays Calibration until the next charging opportunity.

Use Charger Setup Mode to enable or disable Calibration/Reconditioning. When disabled and the IMPRES 2 or IMPRES battery requires Calibration/Reconditioning, the LED indicates **Alternating Amber/Green** at battery insertion and after the battery is charged.

**Note:** The IMPRES 2 or IMPRES battery must be outside the charger pocket for more than 30 minutes for automatic Calibration/Reconditioning.

## IMPRES Battery with Self Calibration and Recondition



**ATTENTION:** IMPRES 2 batteries that has this icon on the battery label do not require periodic calibration and reconditioning when docked into this IMPRES 2 charger (with software version V2.05 or newer).

**Note:** Ensure that your charger is always updated with the latest firmware. The MSI Charger Reprogrammer application package can be downloaded from Motorola Online (MOL) or Motorola Solutions website.

## Updating Firmware

**Note:** Applies to all IMPRES Gen 1 and Gen 2 devices or chargers; which includes Charger Interface Unit (CIU), Battery Data Reader (BDR), Single-Unit Charger (SUC), Dual-Unit Charger (DUC), and Multi-Unit Charger (MUC).

Remove all inserted batteries from target device or charger before upgrading an IMPRES device or charger to a newer version.

1. Connect the device or charger to your computer using USB. The connected device or charger is shown on the main window of the MSI Charger Reprogrammer.

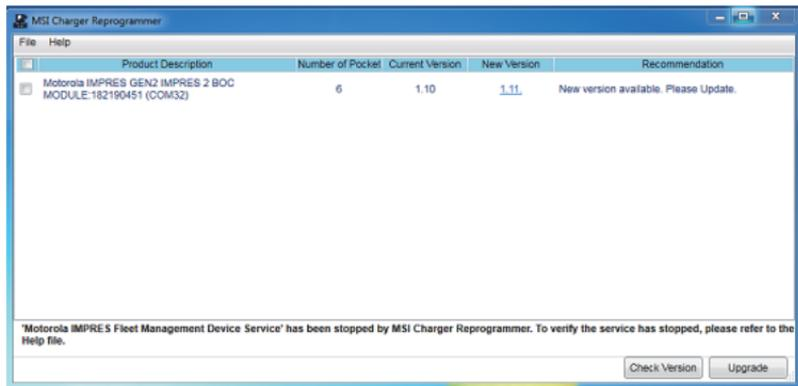

2. Click Check Version to find the latest available version from MSI server.

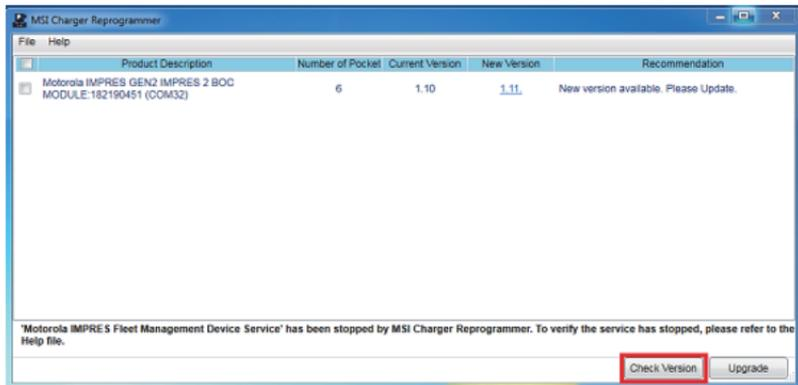

3. Select the device or charger which requires update.

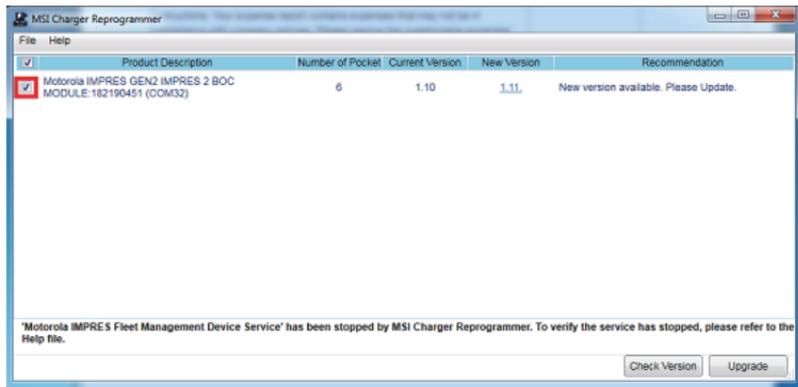

**Note:** You cannot select device or charger already updated with the latest firmware version.

4. To initiate firmware upgrade, click Upgrade.

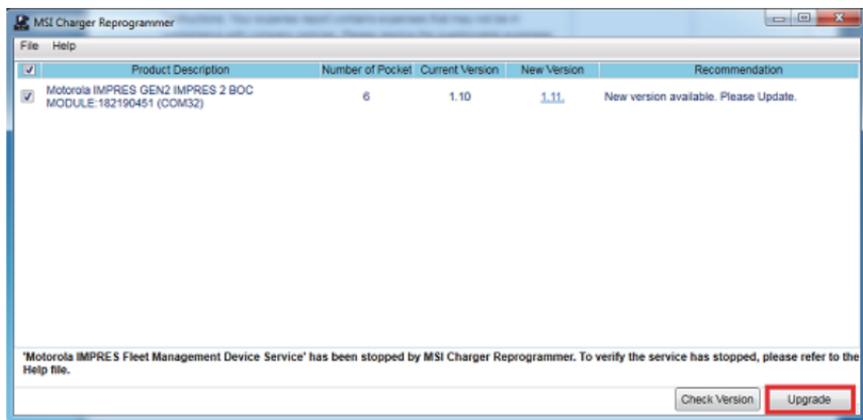

5. Click OK on the confirmation window when prompted to start the upgrade. A window shows the progress of the upgrade until completion.

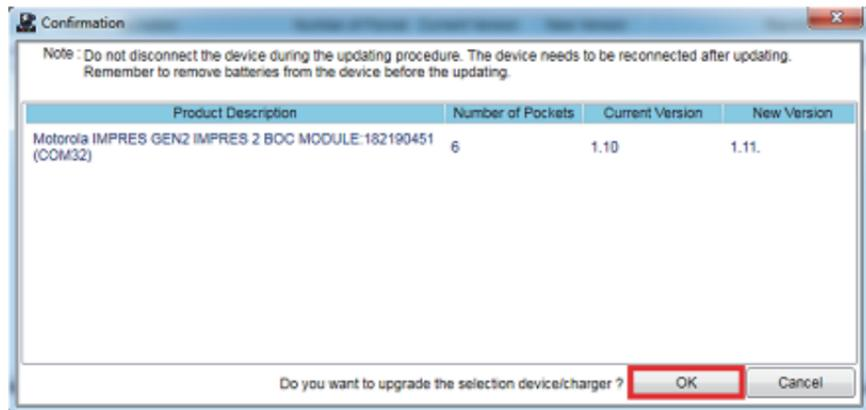

6. Close the window once all upgrades have been completed.

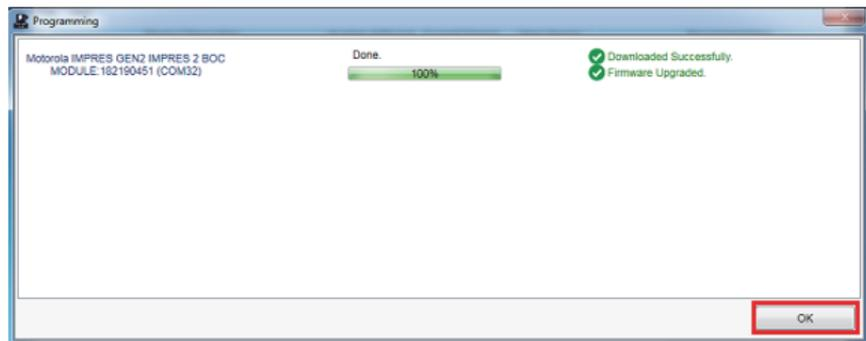

## Manually Initiating Calibration/Reconditioning



**ATTENTION:** Manual calibration or reconditioning does not apply to IMPRES or IMPRES 2 batteries that has this icon.

Though Calibration/Reconditioning is automatic, there may be situations in which manual initiation is desired. For example, the charger may be indicating **Alternating Amber/Green** for the IMPRES 2 or IMPRES battery, because calibration is disabled in the charger. If within 30 minutes that battery is moved to a charger that has calibration enabled, the last charging state resumes, preventing automatic start of Calibration/Reconditioning.

To manually initiate Calibration/Reconditioning, remove the IMPRES 2 or IMPRES battery from the charger for more than 2.5 minutes. Then, perform the following steps:

1. Insert the battery into the charger pocket.
2. Within 2.5 minutes, remove the battery from the charger pocket.
3. Within 5 seconds, reinsert the battery into the charger pocket.

Calibration/Reconditioning starts immediately, typically beginning with Battery Discharge (**Steady Amber**). Calibration/Reconditioning is complete only after full charge (**Steady Green**).

## Manually Terminating Calibration/Reconditioning

At any time during IMPRES 2 or IMPRES battery discharge (Steady Amber), terminate Calibration/Reconditioning by performing the following steps:

1. Remove the battery from the charger pocket.
2. Within 5 seconds, reinsert the battery into the charger pocket.

Battery discharge immediately terminates and normal battery charging starts. The LED indicates Charge Status.

## Charger Overview

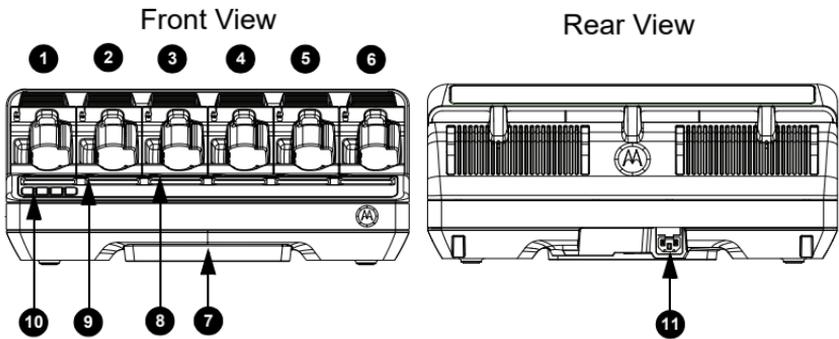

**Figure 1:** Charger Overview

**Table 5:** Charger Overview and Description

No.	Name	Description
1–6	Charger Pockets	Each pocket accommodates a compatible radio or stand-alone battery
7	Communications Module	In certain chargers, the Communications Module also charges USB Accessories: <ul style="list-style-type: none"> <li>• EU/UK PS000029A03</li> <li>• RK PS000029A08</li> </ul>
8	Pocket LED Status Indicator	Charge Status LED (one per pocket)
9	Display	Optional Display for pockets other than Pocket #1
10	Keypad Display	Pocket #1 Display with Menu Keypad
11	AC Inlet Socket	Uses power cord specific to the country or region



## IMPRES 2 or IMPRES End-of-Service-Life LED Indication

The charger may indicate IMPRES 2 or IMPRES battery End-of-Service (**Alternating Red/Green**) upon successful completion of Calibration/Reconditioning.

As batteries are used, normal wear reduces available capacity. At the successful completion of Calibration/Reconditioning, the charger compares IMPRES 2 or IMPRES battery capacity to the battery rated capacity. When the capacity is at a very low value, the IMPRES 2 or IMPRES battery may be nearing its end of service. The IMPRES 2 or IMPRES battery remains usable. In some scenarios, it may be desirable to deploy the battery to someone who does not require large battery capacity to complete a work shift.

APX NEXT XN battery comes with high temperature detection feature that is detectable from IMPRES 2 charger with software version V2.05 or newer. When this feature is enabled, the status LED flashes Red and Green alternately upon charge completion for battery that went through prolonged exposure under extreme high temperature environment. The charger displays the following:

REPLACE BATTERY  
EXPOSED OVERTEMP

It is recommended to remove this battery out from the service.

## Charging Batteries or Radios with Batteries Attached

Batteries charge best at room temperature. IMPRES 2 Multi-Unit Chargers can charge a stand-alone battery or a battery attached to a radio.

1. Place the charger on a flat surface.
2. Firmly insert the power cord into the charger AC Inlet Socket on the back of the charger.
3. Plug the power cord into a matching power outlet.
4. Upon successful power-up, each Charge Status LED flashes **Green** for approximately one second and `IMPRES 2 CHARGER` is displayed. If the Charger Status LEDs do not flash and no message is displayed, check both power cord connections.

5. Insert a radio with attached battery or a stand-alone battery into an available pocket.

**Note:** Grip the body of the radio when inserting or removing it from the charger. Avoid pulling the radio antenna.

6. When the radio or stand-alone battery is properly seated in the pocket, charging status is indicated by the associated Charge Status LED. The associated Display provides additional information. For single-display chargers, the display provides charging status of only Pocket #1.
7. The battery is ready for use when the charging status is **Steady Green**.
8. Turn on the radio only when the Charger Communications Module is detached from a PC. Otherwise, turn OFF the device or radio.

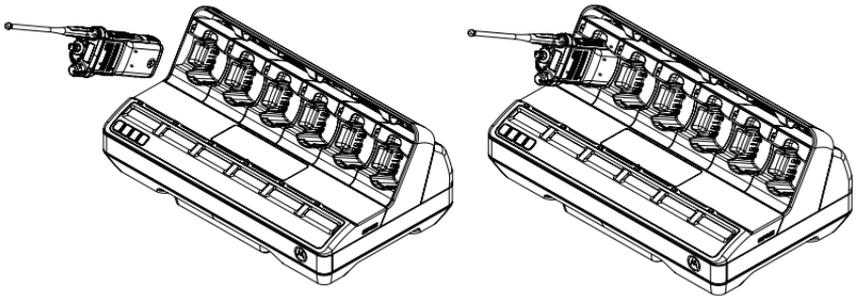

**Figure 2:** Charging Battery Attached to Radio

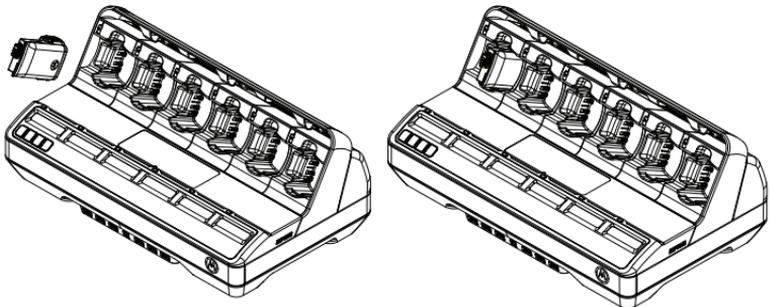

**Figure 3:** Charging Stand-Alone Battery

## Charging USB Accessories

Some IMPRES 2 Multi-Unit Charger Communications Modules provide USB Type-A sockets to charge USB accessories. USB accessories charge best at room temperature.

1. Place the IMPRES 2 Adaptive Charger on a flat surface.
2. Firmly insert the power cord into the charger AC Socket on the back of the charger.
3. Plug the power cord into a matching power outlet.
4. Upon successful power-up, each pocket Status LED flashes **Green** for 1 second and `IMPRES 2 CHARGER` is displayed. If the Status LEDs do not flash and no message is displayed, check power cord connections.
5. A USB accessory can have one Micro-AB receptacle for charging. Use a standard 1-meter or shorter USB cable with a Type A plug on one end and an accessory-compatible plug on the other end (typically Micro-B or Micro-AB).
6. Orient the USB cable Type A plug to align properly with a Type A port on the Communications Module. Insert the plug into the port.
7. Orient the USB cable Micro-B plug to align properly with the Micro-AB receptacle on the USB accessory. Insert the plug into the receptacle.
8. When the USB connections are properly seated, the charging status is indicated by the USB accessory. Refer to the USB accessory User Guide for details.

## Charging Indications

**Table 6:** Charging Indications for IMPRES 2 or IMPRES Battery - Calibration not Required

Status	Pocket Display	LED Indicator
Charger Powers On	IMPRES 2 CHARGER	Green for approximately 1 second 
Battery Detected	IMPRES 2 BATTERY OR IMPRES BATTERY	Steady Red 
Rapid Charging	RAPID CHARGE xxxxx0mAh yyyzPt1	Steady Red 
Charged to 90 % or more	TRICKLE CHARGE xxxxx0mAh yyyzPt1	Flashing Green 
Charged to 95 % or more	CHARGE COMPLETE xxxxx0mAh yyyzPt1	Steady Green 
Fault	WARNING: NOT CHARGEABLE REMOVE & REINSERT	Flashing Red 
Standby <ul style="list-style-type: none"> <li>Battery is waiting to rapid charge.</li> <li>Battery is too hot, too cold, or low voltage.</li> <li>Charger is too hot.</li> </ul>	WARNING: HOT BATTERY WAITING TO CHARGE OR COLD BATTERY WAITING TO CHARGE OR VERY LOW BATTERY WAITING TO CHARGE OR HOT CHARGER WAITING TO CHARGE	Flashing Amber 

### Note:

- The Hot Charger message is introduced in V1.05 software.
- State of Charger percentage indications, with respect to Potential Capacity versus Rated Capacity, is introduced in V1.11.01 software.

**Table 7: Charging Indications for IMPRES 2 or IMPRES Battery Calibration - Calibration Enabled**

Status	Pocket Display	LED Indicator
Charger Powers On	IMPRES 2 CHARGER	Green for approximately 1 second 
Battery Detected	IMPRES 2 BATTERY OR IMPRES BATTERY	Steady Amber 
Battery Discharging	CAL DISCHARGE xxxxx0mAh yy%Pt1	Steady Amber 
Rapid Charging	CAL RAPID CHARGE xxxxx0mAh yy%Pt1	Steady Red 
Charged to 90 % or more	CAL TRICKLE CHARGE xxxxx0mAh yy%Pt1	Flashing Green 
Charged to 95 % or more		Battery Calibration successful: Steady Green 
	CHARGE COMPLETE xxxxx0mAh yy%Pt1	Battery Calibration successful, but may be nearing End of Service (battery is usable): Flashing Red / Green 
	REPLACE BATTERY EXPOSED OVERTEMP	Battery Calibration successful, but battery has been exposed to cumulative over temperature (advise to remove from fleet): Flashing Red/Green  NOTE: Applicable only for APX NEXT XN battery
Fault	WARNING: NOT CHARGEABLE REMOVE & REINSERT	Flashing Red 

**Table 7: Charging Indications for IMPRES 2 or IMPRES Battery Calibration - Calibration Enabled (Cont.)**

Status	Pocket Display	LED Indicator
<p>Standby</p> <ul style="list-style-type: none"> <li>• Battery is waiting to rapid charge.</li> <li>• Battery is too hot, too cold, or low voltage.</li> <li>• Charger is too hot.</li> </ul>	<p>WARNING:  HOT BATTERY  WAITING TO CAL  OR  COLD BATTERY  WAITING TO CAL  OR  VERY LOW BATTERY  WAITING TO CHARGE  OR  HOT CHARGER  WAITING TO CAL</p>	<p>Flashing Amber</p> 

**Table 8: Charging Indications for IMPRES 2 or IMPRES Battery Calibration - Calibration initially Disabled, then Enabled**

Status	Charger Display	LED Indicator
Charger Powers On	IMPRES 2 CHARGER	Green for approximately 1 second 
Battery Detected	IMPRES 2 BATTERY or IMPRES BATTERY	Battery requires Calibration, but Calibration is disabled in charger: Alternating Amber / Green for 4 seconds  
Requesting IMPRES Battery Calibration <ul style="list-style-type: none"> <li>• Calibration is disabled in charger.</li> <li>• Battery is charging</li> </ul>	WARNING: ENABLE BATTERY CALIBRATION?  • Press OK to enable Calibration • Ignore for normal charging (message removed after 1 minute)	Steady Red 
Battery Discharging <ul style="list-style-type: none"> <li>• OK selected</li> </ul>	CAL DISCHARGE xxxxx@mAh yyy%P t1	Steady Amber 
Rapid Charging	CAL RAPID CHARGE xxxxx@mAh yyy%P t1	Steady Red 
Charged to 90 % or more	CAL TRICKLE CHARGE xxxxx@mAh yyy%P t1	Flashing Green 
Charged to 95 % or more	CHARGE COMPLETE xxxxx@mAh yyy%P t1	Battery Calibration successful: Steady Green   Battery Calibration successful, but may be nearing End of Service (battery is usable): Flashing Red / Green  
	REPLACE BATTERY EXPOSED OVERTEMP	Battery Calibration successful, but battery has been exposed to cumulative over temperature (advise to remove from fleet): Flashing Red/Green   NOTE: Applicable only for APX NEXT XN battery
Fault	WARNING: NOT CHARGEABLE REMOVE& REINSERT	Flashing Red 

**Table 8:** Charging Indications for IMPRES 2 or IMPRES Battery Calibration - Calibration initially Disabled, then Enabled (Cont.)

Status	Charger Display	LED Indicator
<p>Standby</p> <ul style="list-style-type: none"> <li>• Battery is waiting to rapid charge.</li> <li>• Battery is too hot, too cold, or low voltage.</li> <li>• Charger is too hot.</li> </ul>	<p>WARNING:  HOT BATTERY  WAITING TO CAL  OR  COLD BATTERY  WAITING TO CAL  OR  VERY LOW BATTERY  WAITING TO CHARGE  OR  HOT CHARGER  WAITING TO CAL</p>	<p>Flashing Amber</p> 



**Table 9:** Charging Indications for IMPRES 2 or IMPRES Battery - Calibration Required, but not Enabled

Status	Charger Display	LED Indicator
Charger Powers On	IMPRES 2 CHARGER	Green for approximately 1 second 
Battery Detected	IMPRES 2 BATTERY or IMPRES BATTERY	Battery requires Calibration, but Calibration is disabled in charger: Alternating Amber / Green for 4 seconds  
Requesting IMPRES Battery Calibration <ul style="list-style-type: none"> <li>• Calibration is disabled in charger.</li> <li>• Battery is charging.</li> </ul>	WARNING: ENABLE BATTERY CALIBRATION?  • Press OK to enable Calibration. • Ignore for normal charging (message removed after 1 minute).	Steady Red 
Rapid Charging <ul style="list-style-type: none"> <li>• Request for Calibration timed out.</li> </ul>	RAPID CHARGE xxxxx@mAh yyy%P t1	Steady Red 
Charged to 90 % or more	TRICKLE CHARGE xxxxx@mAh yyy%P t1	Flashing Green 
Charged to 95 % or more	CHARGE COMPLETE xxxxx@mAh yyy%P t1	Alternating Amber / Green  
Fault	WARNING: HOT CHARGEABLE REMOVE& REINSERT	Flashing Red 
Standby <ul style="list-style-type: none"> <li>• Battery is waiting to rapid charge.</li> <li>• Battery is too hot, too cold, or low voltage.</li> <li>• Charger is too hot.</li> </ul>	WARNING: HOT BATTERY WAITING TO CHARGE OR COLD BATTERY WAITING TO CHARGE OR VERY LOW BATTERY WAITING TO CHARGE OR HOT CHARGER WAITING TO CHARGE	Flashing Amber 

**Table 10: Charging Indications for Fully Charged IMPRES 2 or IMPRES Battery - Calibration Required, but not Enabled**

Status	Charger Display	LED Indicator
Charger Powers On	IMPRES 2 CHARGER	Green for approximately 1 second 
Battery Detected	IMPRES 2 BATTERY or IMPRES BATTERY	Battery requires Calibration, but was fully charged within the last 30 minutes, but calibration is disabled in charger: Alternating Amber /   Green
Fault	WARNING: NOT CHARGEABLE REMOVE & REINSERT	Flashing Red 
Standby <ul style="list-style-type: none"> <li>• Battery is waiting to rapid charge.</li> <li>• Battery is too hot, too cold, or low voltage.</li> <li>• Charger is too hot.</li> </ul>	WARNING: HOT BATTERY WAITING TO CHARGE OR COLD BATTERY WAITING TO CHARGE OR VERY LOW BATTERY WAITING TO CHARGE OR HOT CHARGER WAITING TO CHARGE	Flashing Amber 

## Other Motorola Solutions Batteries

**Table 11: Charging Indications for Other Motorola Solutions Batteries**

Status	Charger Display	LED Indicator
Charger Powers On	IMPRES 2 CHARGER	Green for approximately 1 second 
Battery Detected	MOTOROLA SOLUTIONS BATTERY	Steady Red 
Rapid Charging	RAPID CHARGE	Steady Red 
Charged to 90 % or more	TRICKLE CHARGE	Flashing Green 
Charged to 95 % or more	CHARGE COMPLETE	Steady Green 
Fault	WARNING: NOT CHARGEABLE REMOVE & REINSERT	Flashing Red 
Standby <ul style="list-style-type: none"> <li>Battery is waiting to rapid charge.</li> <li>Battery is too hot, too cold, or low voltage.</li> <li>Charger is too hot.</li> </ul>	WARNING: HOT BATTERY WAITING TO CHARGE OR COLD BATTERY WAITING TO CHARGE OR VERY LOW BATTERY WAITING TO CHARGE OR HOT CHARGER WAITING TO CHARGE	Flashing Amber 

## Unknown Battery

Some unknown batteries may not be detectable by the charger. Unknown batteries do not declare charging parameters in a manner recognizable by the charger. If an unknown battery is detected, then the charger indicates charging as summarized in Table 12.

**Table 12: Charging Indications for Unknown Batteries**

Status	Charger Display	LED Indicator
Charger Powers On	IMPRES 2 CHARGER	Green for approximately 1 second 
Battery Detected	UNKNOWN BATTERY	Steady Red 
Rapid Charging	RAPID CHARGE	Steady Red 
Nearly Charged • Battery Capacity Unknown	TRICKLE CHARGE	Flashing Green 
Charged • Battery Capacity Unknown	CHARGE COMPLETE	Steady Green 
Fault	WARNING: NOT CHARGEABLE REMOVE & REINSERT	Flashing Red 
Standby • Battery is waiting to rapid charge. • Battery is too hot, too cold, or low voltage. • Charger is too hot.	WARNING: HOT BATTERY WAITING TO CHARGE OR COLD BATTERY WAITING TO CHARGE OR VERY LOW BATTERY WAITING TO CHARGE OR HOT CHARGER WAITING TO CHARGE	Flashing Amber 

## IMPRES 2 or IMPRES Battery Long-Term Storage

You can prepare stand-alone authentic Motorola Solutions IMPRES 2 or IMPRES batteries (Lithium-Ion or Nickel) for Long-Term Storage, in a suitable storage location, by using an IMPRES 2 Multi- Unit Charger. Other battery types are faulted. If the IMPRES 2 battery is equipped with a Sleep mode, the charger puts the battery to sleep upon completion of Long-Term Storage charge.

Prepare only the IMPRES 2 or IMPRES batteries for Long-Term Storage. Remove the battery from the radio before placing it into the charger.

DO NOT store a stand-alone battery in the charger. When preparation for Long-Term Storage is complete, immediately remove the stand-alone battery from the charger.

Selection of Long-Term Storage supersedes Calibration/Reconditioning. Lithium batteries prepared for Long-Term Storage may not meet regulations for shipment by air cargo.

**Table 13:** Long-Term Storage Indications of an IMPRES 2 or IMPRES Battery - Battery is due for Calibration

Status	Charger Display	LED Indicator
Charger Powers On	IMPRES 2 CHARGER	Green for approximately 1 second 
Battery Detected	IMPRES 2 BATTERY or IMPRES BATTERY	Battery requires Calibration: Alternating Amber / Green for 4 seconds 
Battery Discharging	STORAGE DISCHARGE xxxx% Rated Cap	Steady Amber 
Rapid Charging	STORAGE CHARGE xxx% Rated Cap	Steady Red 
Long-Term Storage Complete	LONGTERM STORAGE xxx% Rated Cap	Alternating Amber / Green 

**Table 13:** Long-Term Storage Indications of an IMPRES 2 or IMPRES Battery - Battery is due for Calibration (Cont.)

Status	Charger Display	LED Indicator
<b>Fault</b> <ul style="list-style-type: none"> <li>Battery is not making proper electrical contact with the charger.</li> <li>Battery is not an IMPRES 2 or IMPRES battery.</li> <li>An unknown condition is preventing the battery from being discharged.</li> <li>Charging is completed before the Long-Term Storage goal is reached.</li> <li>The charger pocket is a special type.</li> </ul>	WARNING: NOT CHARGEABLE REMOVE& REINSERT OR WRONG BATT TYPE CANNOT LT STORE OR CANNOT DISCHARGE FOR LT STORAGE OR STORE INCOMPLETE Low Capacity:yy% OR RADIO POCKET CANNOT LT STORE OR CHARGING POCKET CANNOT LT STORE	Flashing Red 
<b>Standby</b> <ul style="list-style-type: none"> <li>Battery is waiting to rapid charge.</li> <li>Battery is too hot, too cold, or low voltage.</li> <li>Charger is too hot.</li> </ul>	WARNING: HOT BATTERY WAITING TO CHRGE OR COLD BATTERY WAITING TO CHRGE OR VERY LOW BATTERY WAITING TO CHRGE OR HOT CHARGER WAITING TO CHRGE	Flashing Amber 

**Note:**

- The following messages are introduced in software version V1.05:
  - Cannot Discharge, for LT Storage
  - Store Incomplete, Low Capacity:yy%
  - Hot Charger, Waiting to Chrge
- The following messages are introduced in software version V1.11.01:
  - Wrong Batt Type, Cannot LT Store
  - Radio Pocket, Cannot LT Store
  - Charging Pocket, Cannot LT Store

**Table 14:** Long-Term Storage Indications of an IMPRES 2 or IMPRES Battery - Calibrated Battery, Must Charge Up to Selection

Status	Charger Display	LED Indicator
Charger Powers On	IMPRES 2 CHARGER	Green for approximately 1 second 
Battery Detected	IMPRES 2 BATTERY or IMPRES BATTERY	Steady Red 
Rapid Charging	STORAGE CHARGE xxx% Rated Cap	Steady Red 
Long-Term Storage Complete	LONGTERM STORAGE xxx% Rated Cap	Steady Green 
<b>Fault</b> <ul style="list-style-type: none"> <li>Battery is not making proper electrical contact with the charger.</li> <li>Battery is not an IMPRES 2 or IMPRES battery.</li> <li>An unknown condition is preventing the battery from being discharged.</li> <li>Charging is completed before the Long-Term Storage goal is reached.</li> <li>The charger pocket is a special type.</li> </ul>	<b>WARNING:</b> NOT CHARGEABLE REMOVE & REINSERT OR WRONG BATT TYPE CANNOT LT STORE OR CANNOT DISCHARGE FOR LT STORAGE OR STORE INCOMPLETE Low Capacity:yy% OR RADIO POCKET CANNOT LT STORE OR CHARGING POCKET CANNOT LT STORE	Flashing Red 
<b>Standby</b> <ul style="list-style-type: none"> <li>Battery is waiting to rapid charge.</li> <li>Battery is too hot, too cold, or low voltage.</li> <li>Charger is too hot.</li> </ul>	<b>WARNING:</b> HOT BATTERY WAITING TO CHARGE OR COLD BATTERY WAITING TO CHARGE OR VERY LOW BATTERY WAITING TO CHARGE OR HOT CHARGER WAITING TO CHARGE	Flashing Amber 

**Table 15:** Long-Term Storage Indications of an IMPRES 2 or IMPRES Battery - Calibrated Battery, Must Discharge Down to Selection

Status	Charger Display	LED Indicator
Charger Powers On	IMPRES 2 CHARGER	Green for approximately 1 second 
Battery Detected	IMPRES 2 BATTERY or IMPRES BATTERY	Steady Amber 
Battery Discharging	STORAGE DISCHARGE xxx% Rated Cap	Steady Amber 
Long-Term Storage Complete	LONGTERM STORAGE xxx% Rated Cap	Steady Green 
<b>Fault</b> <ul style="list-style-type: none"> <li>Battery is not making proper electrical contact with the charger.</li> <li>Battery is not an IMPRES 2 or IMPRES battery.</li> <li>An unknown condition is preventing the battery from being discharged.</li> <li>Charging is completed before the Long-Term Storage goal is reached.</li> <li>The charger pocket is a special type.</li> </ul>	<b>WARNING:</b> NOT CHARGEABLE REMOVE& REINSERT OR WRONG BATT TYPE CANNOT LT STORE OR CANNOT DISCHARGE FOR LT STORAGE OR STORE INCOMPLETE Low Capacity:yy% OR RADIO POCKET CANNOT LT STORE OR CHARGING POCKET CANNOT LT STORE	Flashing Red 
<b>Standby</b> <ul style="list-style-type: none"> <li>Battery is waiting to rapid charge.</li> <li>Battery is too hot, too cold, or low voltage.</li> <li>Charger is too hot.</li> </ul>	<b>WARNING:</b> HOT BATTERY WAITING TO CHRGE OR COLD BATTERY WAITING TO CHRGE OR VERY LOW BATTERY WAITING TO CHRGE OR HOT CHARGER WAITING TO CHRGE	Flashing Amber 



## Preparation for Lithium-Ion Battery Shipment

You can prepare stand-alone IMPRES 2, IMPRES, or other authentic Motorola Solutions Lithium-Ion batteries for shipment by air cargo using an IMPRES 2 Multi-Unit Charger. Other battery types are faulted. If the IMPRES 2 Lithium-Ion battery is equipped with a Sleep mode, the charger puts the battery to sleep upon completion of Ship Lithium charge.

Prepare only stand-alone Motorola Solutions Lithium-Ion batteries for shipment. Remove the battery from the radio before placing it into the charger.

DO NOT store a stand-alone battery in the charger. When preparation for Lithium Shipment is complete, immediately remove the stand-alone battery from the charger.

Selection of Lithium Shipment supersedes Calibration/Reconditioning.

### IMPRES 2 or IMPRES Battery

**Table 16:** Status Indications of a Lithium-Ion Battery Prepared for Shipment - IMPRES 2 or IMPRES Battery is due for Calibration

Status	Charger Display	LED Indicator
Charger Powers On	IMPRES 2 CHARGER	Green for approximately 1 second 
Battery Detected	IMPRES 2 BATTERY or IMPRES BATTERY	Battery requires Calibration: Alternating Amber / Green for 4 seconds 
Battery Discharging	SHIP LI DISCHARGE xxx% Rated Cap	Steady Amber 
Rapid Charging	SHIP LI CHARGE xxx% Rated Cap	Steady Red 
Ship Lithium Complete	LI READY TO SHIP xxx% Rated Cap	Alternating Amber / Green 

**Table 16:** Status Indications of a Lithium-Ion Battery Prepared for Shipment - IMPRES 2 or IMPRES Battery is due for Calibration (Cont.)

Status	Charger Display	LED Indicator
<b>Fault</b> <ul style="list-style-type: none"> <li>Battery is not making proper electrical contact with the charger.</li> <li>Battery is Unknown or Nickel.</li> <li>An unknown condition is preventing the battery from being discharged.</li> <li>Charging is completed before the Ship Lithium goal is reached.</li> <li>The charger pocket is a special type.</li> </ul>	WARNING: HOT CHARGEABLE REMOVE& REINSERT OR WRONG BATT TYPE CANNOT SHIP LI OR CANNOT DISCHARGE FOR LI SHIPMENT OR SHIP INCOMPLETE Low Capacity:yy% OR RADIO POCKET CANNOT SHIP LI OR CHARGING POCKET CANNOT SHIP LI	Flashing Red 
<b>Standby</b> <ul style="list-style-type: none"> <li>Battery is waiting to rapid charge.</li> <li>Battery is too hot, too cold, or low voltage.</li> <li>Charger is too hot.</li> </ul>	WARNING: HOT BATTERY WAITING TO CHRGE OR COLD BATTERY WAITING TO CHRGE OR VERY LOW BATTERY WAITING TO CHRGE OR HOT CHARGER WAITING TO CHRGE	Flashing Amber 

**Note:**

- The following messages are introduced in software version V1.05:
  - Ship LI Discharge, xxx% Rated Capacity
  - Ship LI Charge, xxx% Rated Capacity
  - LI Ready to Ship, xx% Rated Capacity
  - Cannot Discharge, for LI Shipment
  - Ship Incomplete, Low Capacity:yy%
- The following messages are introduced in software version V1.11.01:
  - Wrong Batt Type, Cannot Ship LI
  - Radio Pocket, Cannot Ship LI
  - Charging Pocket, Cannot Ship LI

**Table 17:** Status Indications of a Lithium-Ion Battery Prepared for Shipment - IMPRES 2 or IMPRES Battery Calibrated, Must Charge

Status	Charger Display	LED Indicator
Charger Powers On	IMPRES 2 CHARGER	Green for approximately 1 second 
Battery Detected	IMPRES 2 BATTERY or IMPRES BATTERY	Steady Red 
Rapid Charging	SHIP LI CHARGE xxx% Rated Cap	Steady Red 
Ship Lithium Complete	LI READY TO SHIP xxx% Rated Cap	Steady Green 
<b>Fault</b> <ul style="list-style-type: none"> <li>Battery is not making proper electrical contact with the charger.</li> <li>Battery Unknown or Nickel</li> <li>An unknown condition is preventing the battery from being discharged.</li> <li>Charging is completed before the Ship Lithium goal is reached.</li> <li>The charger pocket is a special type.</li> </ul>	<b>WARNING:</b> NOT CHARGEABLE REMOVE & REINSERT OR WRONG BATT TYPE CANNOT SHIP LI OR CANNOT DISCHARGE FOR LI SHIPMENT OR SHIP INCOMPLETE Low Capacity:yy% OR RADIO POCKET CANNOT SHIP LI OR CHARGING POCKET CANNOT SHIP LI	Flashing Red 
<b>Standby</b> <ul style="list-style-type: none"> <li>Battery is waiting to rapid charge.</li> <li>Battery is too hot, too cold, or low voltage.</li> <li>Charger is too hot.</li> </ul>	<b>WARNING:</b> HOT BATTERY WAITING TO CHARGE OR COLD BATTERY WAITING TO CHARGE OR VERY LOW BATTERY WAITING TO CHARGE OR HOT CHARGER WAITING TO CHARGE	Flashing Amber 

**Table 18:** Status Indications of a Lithium-Ion Battery Prepared for Shipment - IMPRES 2 or IMPRES Battery Calibrated, Must Discharge

Status	Charger Display	LED Indicator
Charger Powers On	IMPRES 2 CHARGER	Green for approximately 1 second 
Battery Detected	IMPRES 2 BATTERY or IMPRES BATTERY	Steady Amber 
Battery Discharging	SHIP LI DISCHARGE xxx% Rated Cap	Steady Amber 
Ship Lithium Complete	LI READY TO SHIP xxx% Rated Cap	Steady Green 
<b>Fault</b> <ul style="list-style-type: none"> <li>Battery is not making proper electrical contact with the charger.</li> <li>Battery Unknown or Nickel</li> <li>An unknown condition is preventing the battery from being discharged.</li> <li>Charging is completed before the Ship Lithium goal is reached.</li> <li>The charger pocket is a special type.</li> </ul>	<b>WARNING:</b> NOT CHARGEABLE REMOVE & REINSERT OR WRONG BATT TYPE CANNOT SHIP LI OR CANNOT DISCHARGE FOR LI SHIPMENT OR SHIP INCOMPLETE Low Capacity:yy% OR RADIO POCKET CANNOT SHIP LI OR CHARGING POCKET CANNOT SHIP LI	Flashing Red 
<b>Standby</b> <ul style="list-style-type: none"> <li>Battery is waiting to rapid charge.</li> <li>Battery is too hot, too cold, or low voltage.</li> <li>Charger is too hot.</li> </ul>	<b>WARNING:</b> HOT BATTERY WAITING TO CHARGE OR COLD BATTERY WAITING TO CHARGE OR VERY LOW BATTERY WAITING TO CHARGE OR HOT CHARGER WAITING TO CHARGE	Flashing Amber 

## Other Motorola Solutions Batteries

**Table 19:** Status Indications of a Lithium-Ion Battery Prepared for Shipment - Other Motorola Solutions Battery

Status	Charger Display	LED Indicator
Charger Powers On	IMPRES 2 CHARGER	Green for approximately 1 second 
Battery Detected	MOTOROLA SOLUTIONS BATTERY	Steady Amber 
Battery Discharging	SHIP LI DISCHARGE xxx% Rated Cap	Steady Amber 
Rapid Charging	SHIP LI CHARGE xxx% Rated Cap	Steady Red 
Ship Lithium Complete	LI READY TO SHIP xxx% Rated Cap	Steady Green 
<b>Fault</b> <ul style="list-style-type: none"> <li>Battery is not making proper electrical contact with the charger.</li> <li>Battery Unknown or Nickel</li> <li>An unknown condition is preventing the battery from being discharged.</li> <li>Charging is completed before the Ship Lithium goal is reached.</li> <li>The charger pocket is a special type.</li> </ul>	<b>WARNING:</b> NOT CHARGEABLE REMOVE & REINSERT OR WRONG BATT TYPE CANNOT SHIP LI OR CANNOT DISCHARGE FOR LI SHIPMENT OR SHIP INCOMPLETE Low Capacity:yy% OR RADIO POCKET CANNOT SHIP LI OR CHARGING POCKET CANNOT SHIP LI	Flashing Red 
<b>Standby</b> <ul style="list-style-type: none"> <li>Battery is waiting to rapid charge.</li> <li>Battery is too hot, too cold, or low voltage.</li> <li>Charger is too hot.</li> </ul>	<b>WARNING:</b> HOT BATTERY WAITING TO CHARGE OR COLD BATTERY WAITING TO CHARGE OR VERY LOW BATTERY WAITING TO CHARGE OR HOT CHARGER WAITING TO CHARGE	Flashing Amber 

## Charger Setup Menu



Empty all charger pockets before entering charger setup.

The charger keypad is located below the Pocket #1 display.

To enter Charger Setup, simultaneously press and hold the Left Arrow and Right Arrow buttons for more than the Entry Time selection (3 seconds, default).

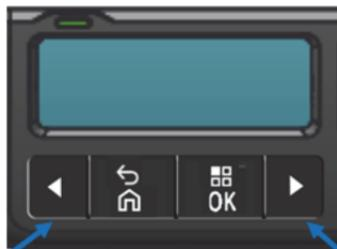

Left Arrow

Right Arrow

**Figure 4:** Menu Display Buttons for Entry to Setup Mode

### Main Menu

Upon entry to Charger Setup, the following message is displayed:

```
Press OK to entr  
SETUP MENU
```

Pressing OK prompts display of available Charger Setup Menu.

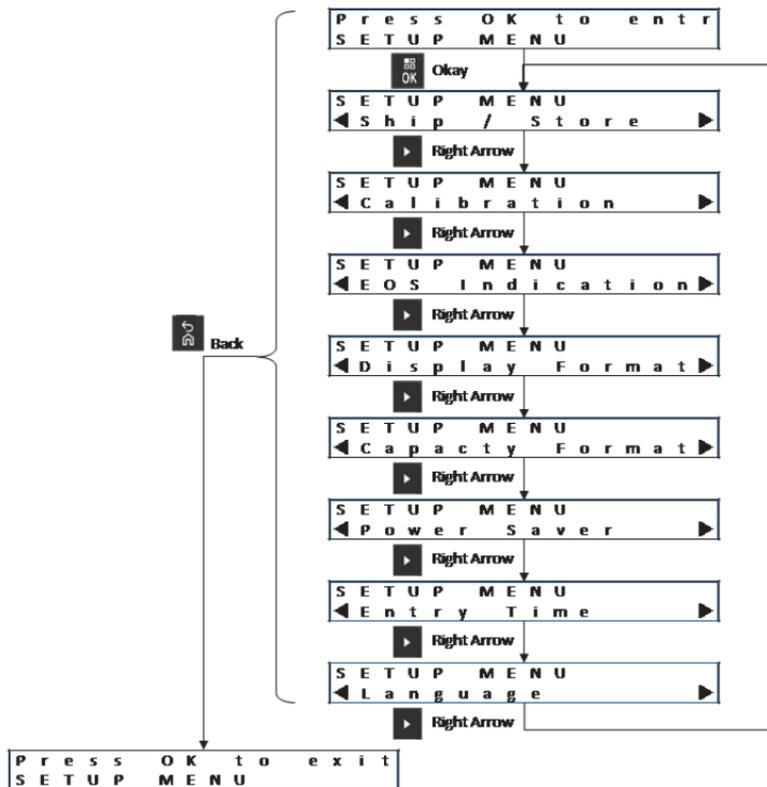

Figure 5: Charger Setup Menu

## Charger Setup Menu Selection

Within each Setup Menu selection:

- To sequence through the menu selections, press the Right Arrow.
- To sequence through the menu selections in reverse order, press the Left Arrow.
- To enter the selected menu or select the desired option, press OK.

**Note:** The check mark identifies the currently selected option.

Introduced in V1.11.01, press OK to display the next pocket on the Pocket #1 display.

- To exit the selected menu, press Back then press OK to confirm exit.

If no Keypad button is pressed for 10 minutes, then the charger exits Charger Setup and returns to normal message displays.

Charger Setup selections are stored in non-volatile memory. Selections are not affected by cycling charger power.

## Ship or Storage Menu

There are four Ship / Storage options:

- Disabled
- Ship Lithium-Ion
- Long-Term Storage
- Long-Term Storage at 75% of Rated Capacity

Ship Lithium-ion, Long-Term Storage, and Long-Term Storage 75% selections supersede the Calibration setting.

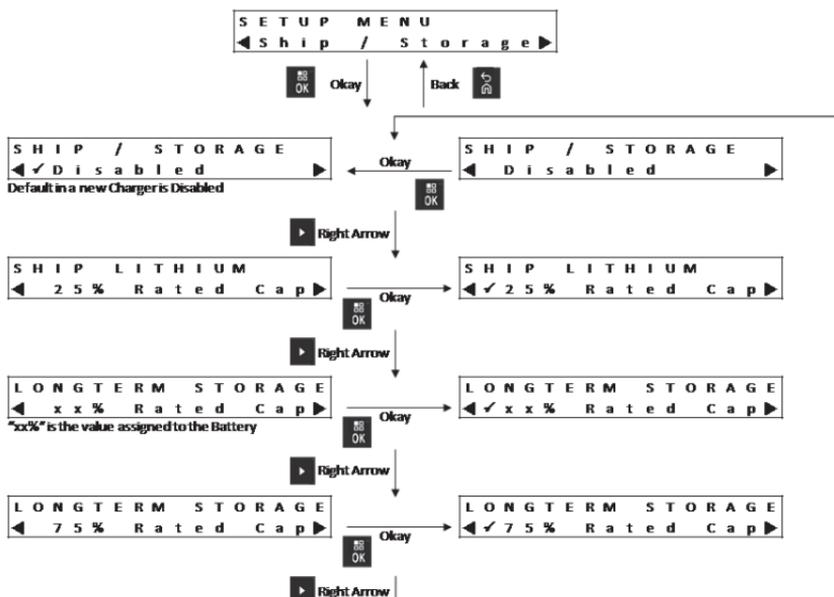

Figure 6: Ship / Storage Menu



## Ship Lithium

Ship Lithium sets the State of Charge of a Motorola Solutions Lithium-Ion battery to a low value permitted for bulk shipment: approximately 25 % of rated capacity.

Some Motorola Solutions batteries may be fully discharged before charging up to the Ship Lithium limit. Such batteries include IMPRES 2 or IMPRES batteries that were never calibrated or require a new calibration and other authentic Motorola Solutions batteries that are not IMPRES 2 or IMPRES.

Ship Lithium applies only to authentic Motorola Solutions Lithium-Ion batteries (IMPRES 2, IMPRES, or other Motorola Solutions Lithium-Ion batteries). Other batteries (such as Unknown or Motorola Solutions Nickel or Clamshell batteries) are faulted.

## Long-Term Storage

Long-Term Storage sets the IMPRES 2 or IMPRES battery to a state of charge suitable for placement into storage for a long period of time. Generally, the preferred storage state of charge is significantly less than full charge. The  $xx\%$  selection is a value programmed in the IMPRES 2 or IMPRES battery or, by default, 50 % of rated capacity. Long-Term Storage at 75 % Rated Capacity is available for scenarios requiring the stored battery to be at a higher state of charge, for example, minimizing full-charge time if the battery must be quickly fielded or enabling storage for a longer period of time.

Some IMPRES 2 or IMPRES batteries may be fully discharged before charging to the Long-Term Storage selection. Such batteries are IMPRES 2 or IMPRES batteries that were never calibrated or require a new calibration.

Long-Term Storage applies only to IMPRES 2 or IMPRES batteries. Other batteries (such as Unknown or Motorola Solutions non-IMPRES or Clamshell batteries) are faulted.

## IMPRES 2 Batteries with Sleep Mode

Some IMPRES 2 batteries are equipped with a Sleep mode. Sleep mode is used to extend the time until the next battery charge. Upon completion of Ship Lithium or Long-Term Storage charging, the charger puts these batteries to sleep.

Placing a sleeping IMPRES 2 battery into any charger will wake it up. If the battery is prepared for Lithium Shipment, placing it into a charger set to Ship Lithium will put the battery back to sleep. If the battery is prepared for Long-Term Storage, placing it into a charger set for Long-Term Storage will put the battery back to sleep.

## Calibration Menu

The Calibration setup selections enables or disables the Discharge phase of Calibration/Reconditioning. The Discharge phase precedes the full charge required for successful Calibration/Reconditioning. This feature is useful when the charger is deployed to a location requiring the battery to be for use as quickly as possible. In these situations, waiting for the battery to discharge may be inconvenient.

If an IMPRES 2 or IMPRES battery is due for calibration and is already discharged when inserted into the charger, the charger takes the opportunity to use charge completion as battery calibration.

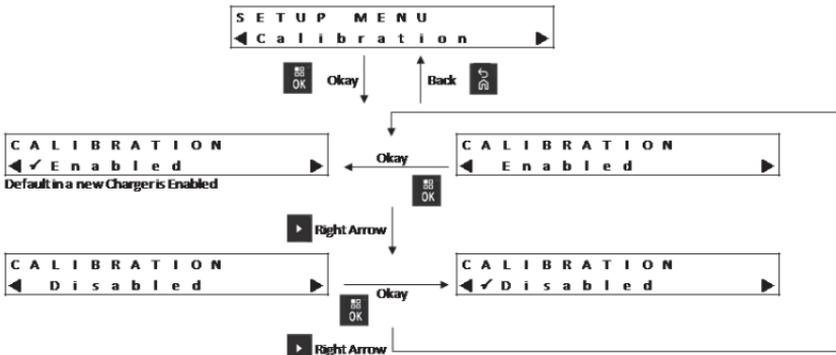
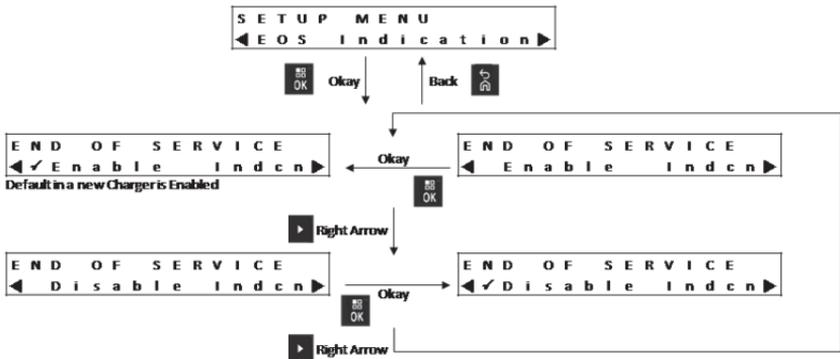

Figure 7: Calibration Menu

## End-of-Service Life LED Indication Menu

Even though the IMPRES 2 or IMPRES battery may be nearing its End of Service, the battery capacity may be more than adequate for lighter use. As a result, it may be desirable to disable the End of Service Life LED Indication (**Alternating Red / Green**).

For APX NEXT XN battery, disabling this indication disables the cumulative over temperature exposed battery indication as well.



**Figure 8:** End-of-Service Life LED Indication Menu

## Display Format Menu

There are four Display Format options:

- Normal orientation (charger sitting on a desktop).
- Inverted orientation (charger hanging on a wall).
- Warning messages only. Other messages are not displayed. This applies to Normal and Inverted orientations. Warning messages are identified in Table 6 through Table 12.
- Display off during Normal operation. The display is always enabled in Setup Mode and Analyzer Mode.

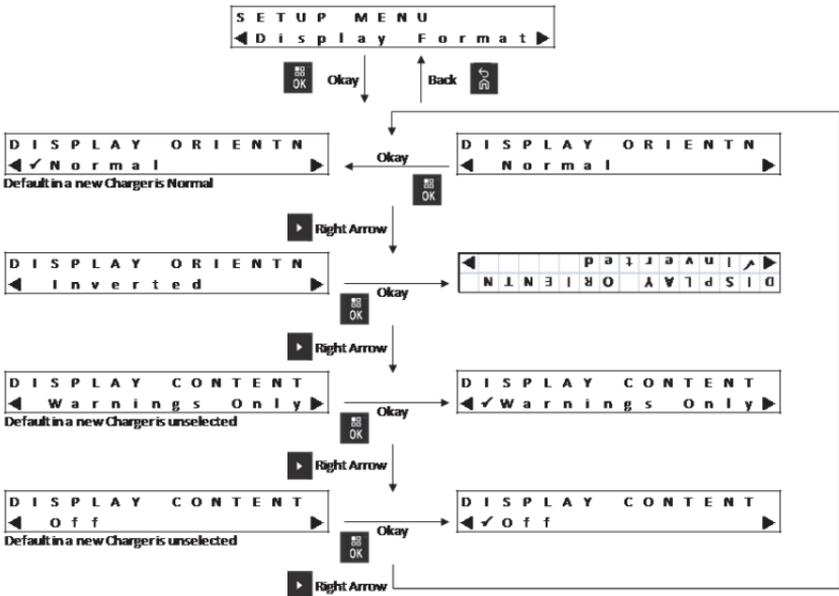

Figure 9: Display Format Menu

## Capacity Format Menu

Battery Capacity is displayed in one of several available formats. If the Battery Capacity is displayed as a percentage, the percentage is referenced to either Potential Capacity (full charge) or Rated Capacity. Typically, IMPRES radios display Battery Capacity percentage referenced to Potential Capacity.

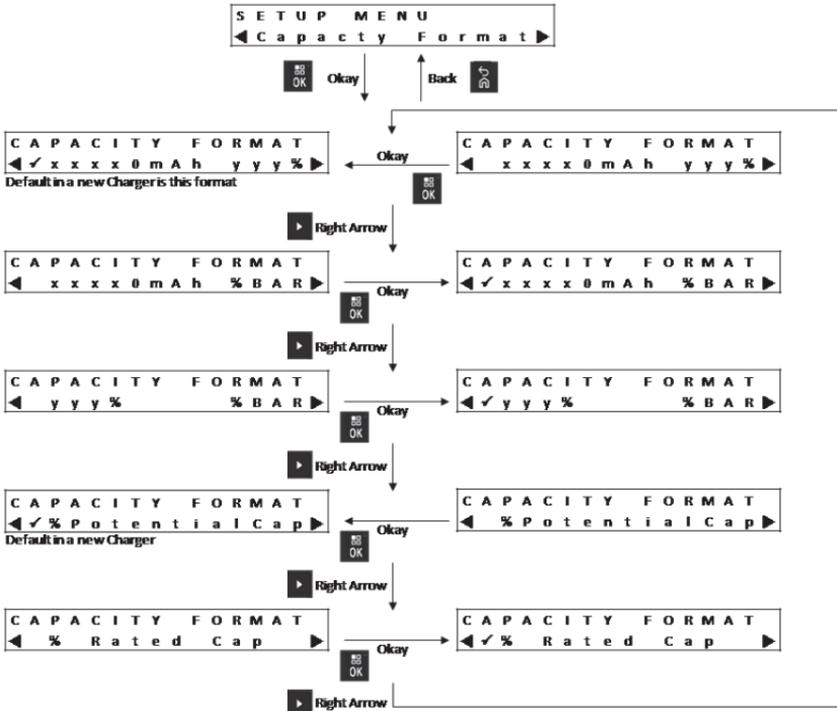

Figure 10: Capacity Format Menu

**Table 20: Battery Capacity Display Options**

Representation	Description
xxx0mAh	Present Charge (State of Charge) in milliamp-hours.
yyy%	Present Charge relative to the Potential Capacity or Rated Capacity, in percent. When referenced to Potential Capacity, the maximum value is 100%. When referenced to Rated Capacity, the maximum value may be greater than 100%, especially for a new battery.
%BAR	The equivalent of yyy% represented in an eight-segment bar.

## Power Saver Menu

To meet certain government low standby power limits, Power Saver mode enables the charger to turn off all pockets except Pocket #1 when there is no activity in those pockets for a period of time.

Examples of activity include the following:

- Radio or battery charging.
- Battery Calibration/Reconditioning.
- Authentic Motorola Solutions Lithium-Ion battery preparation for shipment.
- IMPRES 2 or IMPRES battery preparation for Long-Term Storage.
- Charger Setup Mode Analysis Mode.
- Charger Reprogramming.
- Communicating with the IMPRES Battery Fleet Management System.
- Any flashing LED indication.

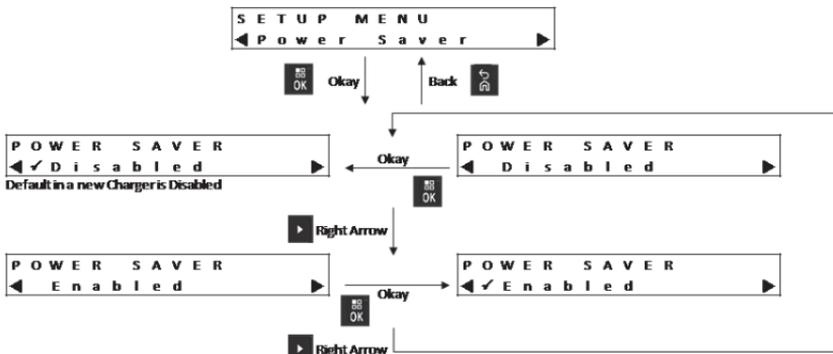

**Figure 11: Power Saver Menu**

Pocket #1 remains on, but may be sleeping. To turn on the other pockets, press any keypad button. Until the other pockets are turned on, they cannot respond to radio or battery insertion, or removal.

## Entry Time Menu

Entry Time is the button press and hold time necessary to enter Charger Setup mode or Charger Analyzer mode.

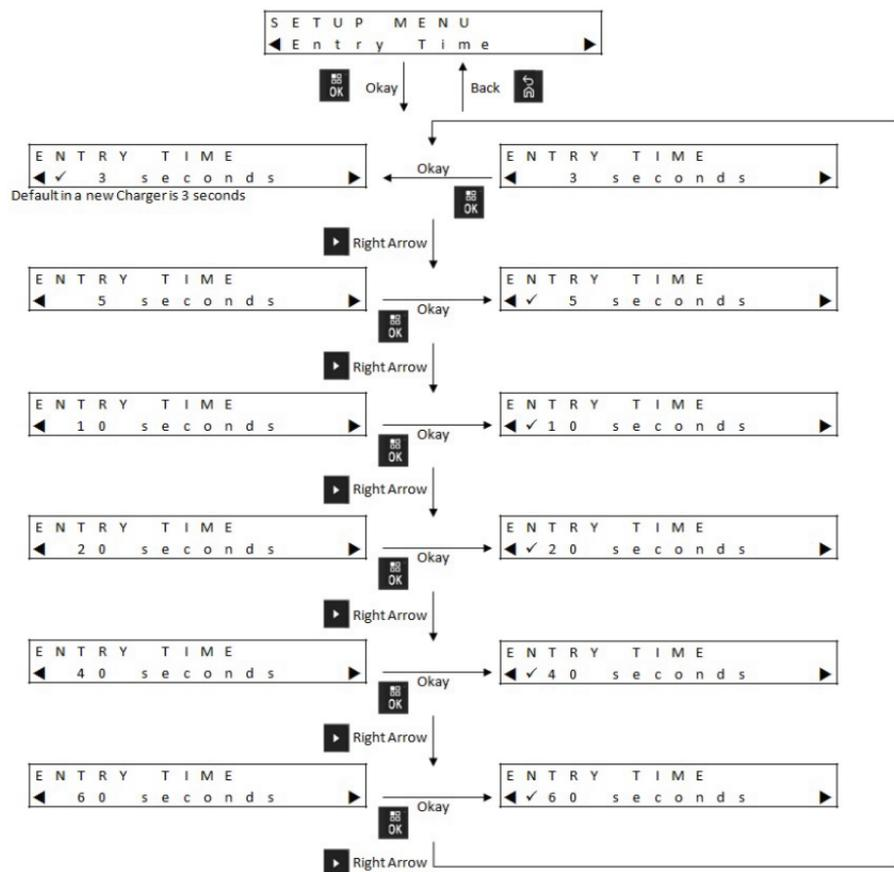
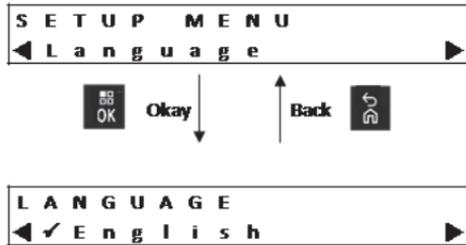

Figure 12: Entry Time Menu

## Language Menu

Currently, the charger displays support on language: North American English.



**Figure 13:** Language Menu

## Analyzer Mode

The charger keypad is located below the Pocket #1 display.

To enter Analyzer Mode, press and hold the OK button for more than the Entry Time selection (3 seconds, default).



**Figure 14:** Menu Display Button for Entry to Analyzer Mode

Upon entry to Analyzer Mode, the following message is displayed:

```
Press OK to entr
ANALYZER MODE
```

Pressing OK prompts display of available battery information.



## Version V1.0 Analyzer Mode

In software version V1.0, Analyzer Mode is limited to Pocket #1. Analyzer information regarding Pocket #1 and its contents are presented on the Pocket #1 display. If no keypad button is pressed for 10 minutes, the charger exits Analyzer Mode and returns to normal message displays.

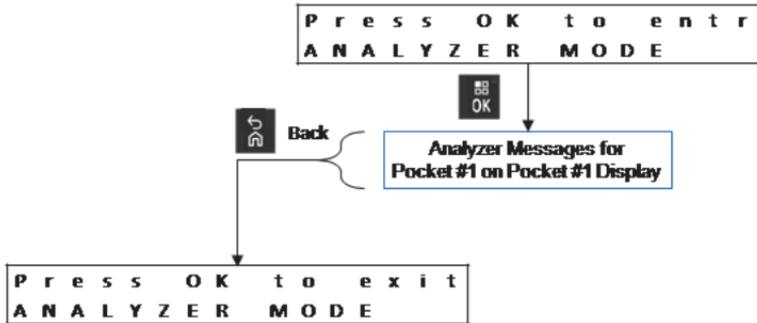

Figure 15: Version V1.0 Analyzer Mode Menu

## Version V1.05 Analyzer Mode

Analyzer Mode is enhanced with the release of software version V1.05. For chargers with a display on each pocket, Analyzer information is displayed on the display adjacent to its pocket. When browsing through Analyzer information on Pocket #1, other displays browse through Analyzer information available for its adjacent pocket.

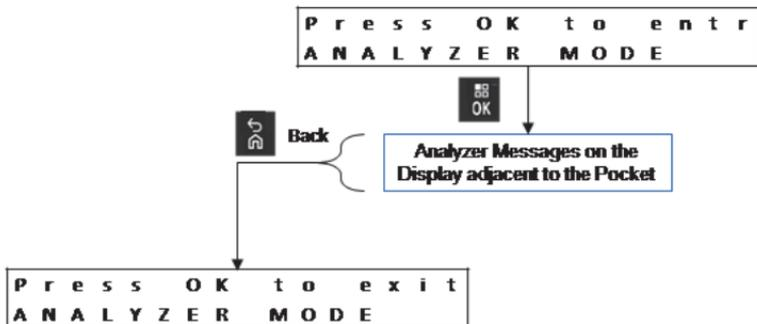
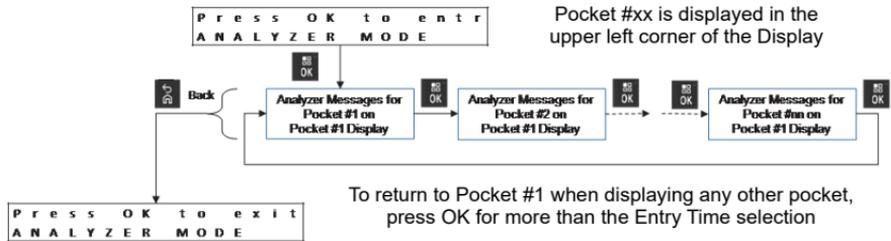

Figure 16: Version V1.05 Analyzer Mode Menu

## Version V1.11.01 Analyzer Mode

Analyzer Mode is enhanced again with the release of software version V1.11.01. For chargers with a display only on Pocket #1, the Pocket #1 Menu Display is used to display information for any other charger pocket. The version V1.05 enhancement remains.



**Figure 17:** Version V1.11.01 Analyzer Mode Menu

## Swapping Batteries in a Pocket

If a battery is removed and then the same or a different battery is inserted into the same pocket, the parameter displayed for the second battery is the same parameter that was being displayed for the first battery.

For example, `Battery IMPRES Cycles` is being displayed for an IMPRES 2 or IMPRES battery. This battery is removed from the pocket. A different IMPRES 2 or IMPRES battery is inserted into the same pocket. The first parameter displayed for the second battery shows `Battery IMPRES Cycles`.

However, the second battery may not have the parameter displayed for the first battery. In this case, the identification message is displayed for the second battery.

# IMPRES 2 Battery

## Display Adjacent to Pocket

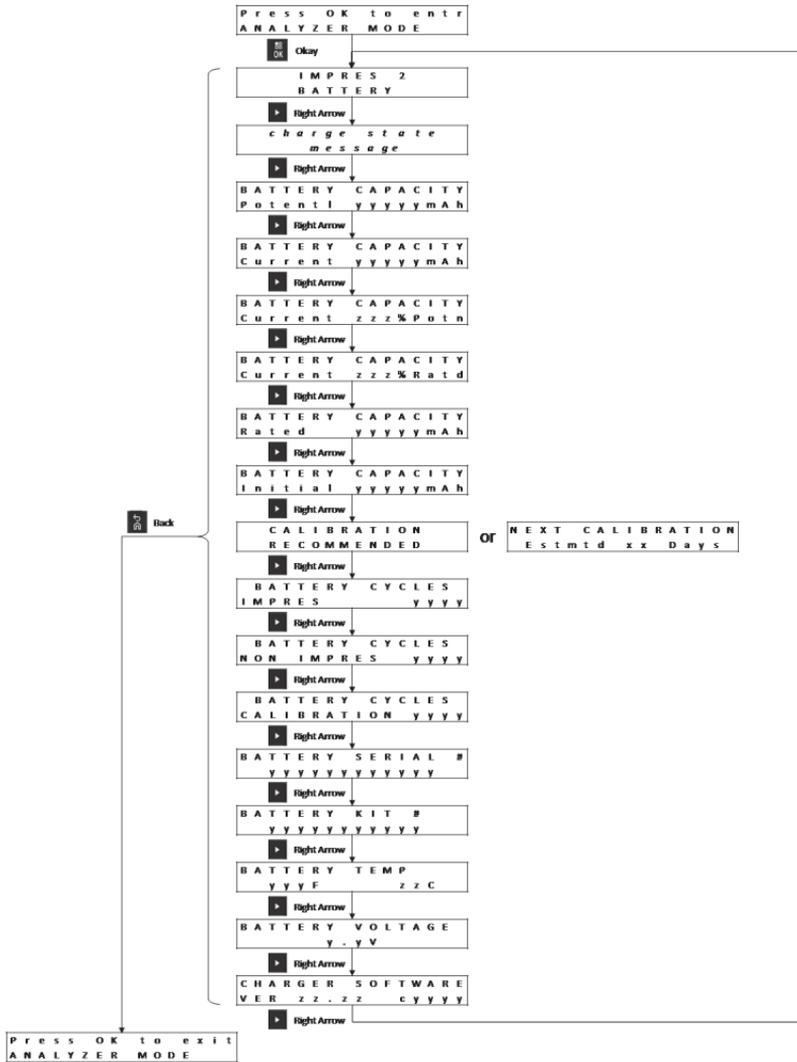

Figure 18: IMPRES 2 Battery Analyzer Mode Menu for Display Adjacent to Pocket

# Pocket #1 Displaying Another Pocket

Pocket #xx is displayed in the upper left corner of the Display

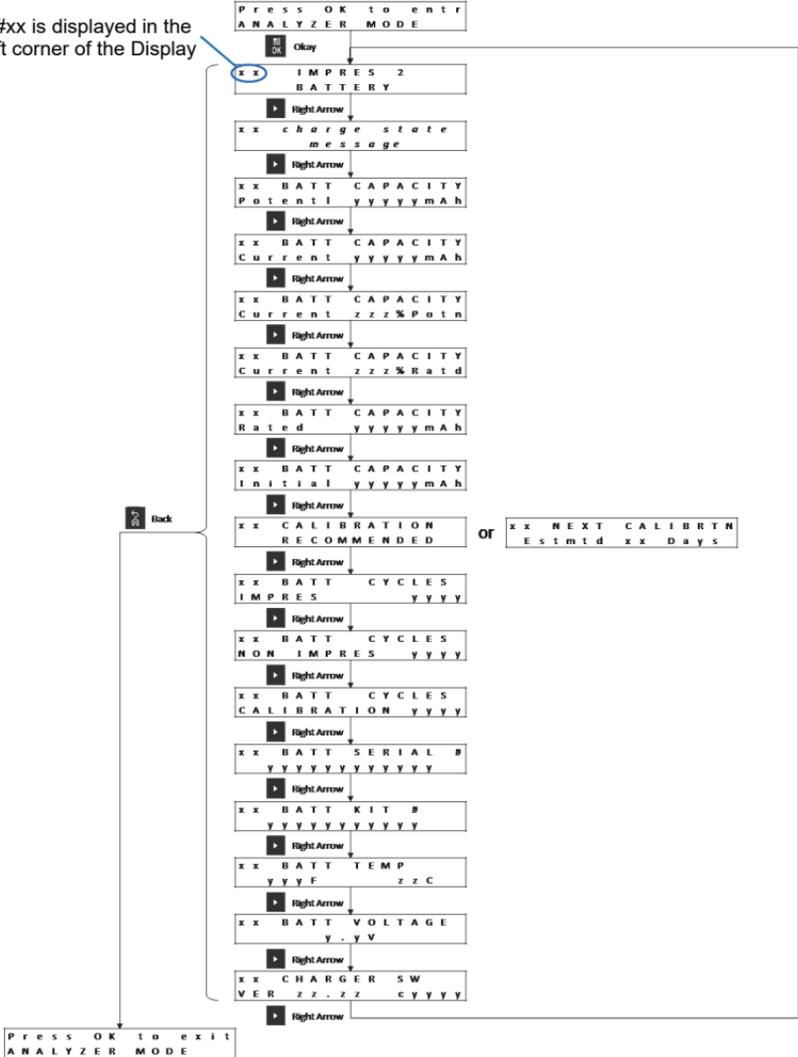

Figure 19: IMPRES 2 Battery Analyzer Mode Menu for Another Pocket (not Pocket #1)

# IMPRES Battery

## Display Adjacent to Pocket

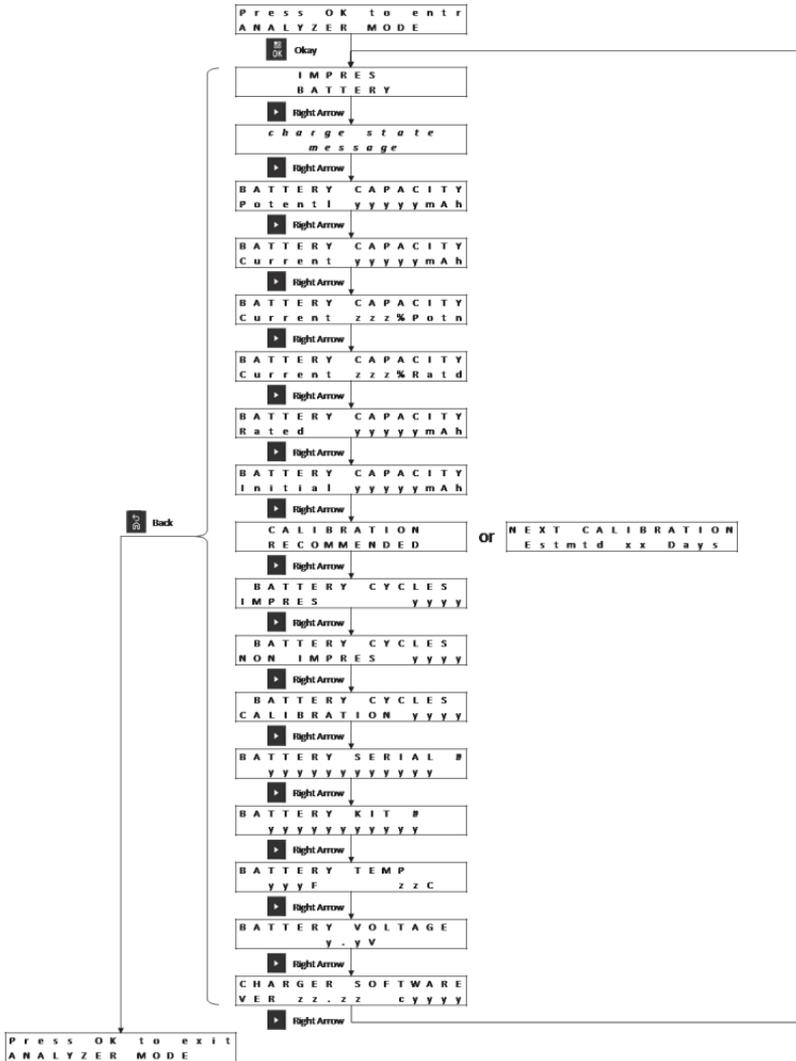

Figure 20: IMPRES Battery Analyzer Mode Menu for Display Adjacent to Pocket

# Pocket #1 Displaying Another Pocket

Pocket #xx is displayed in the upper left corner of the Display

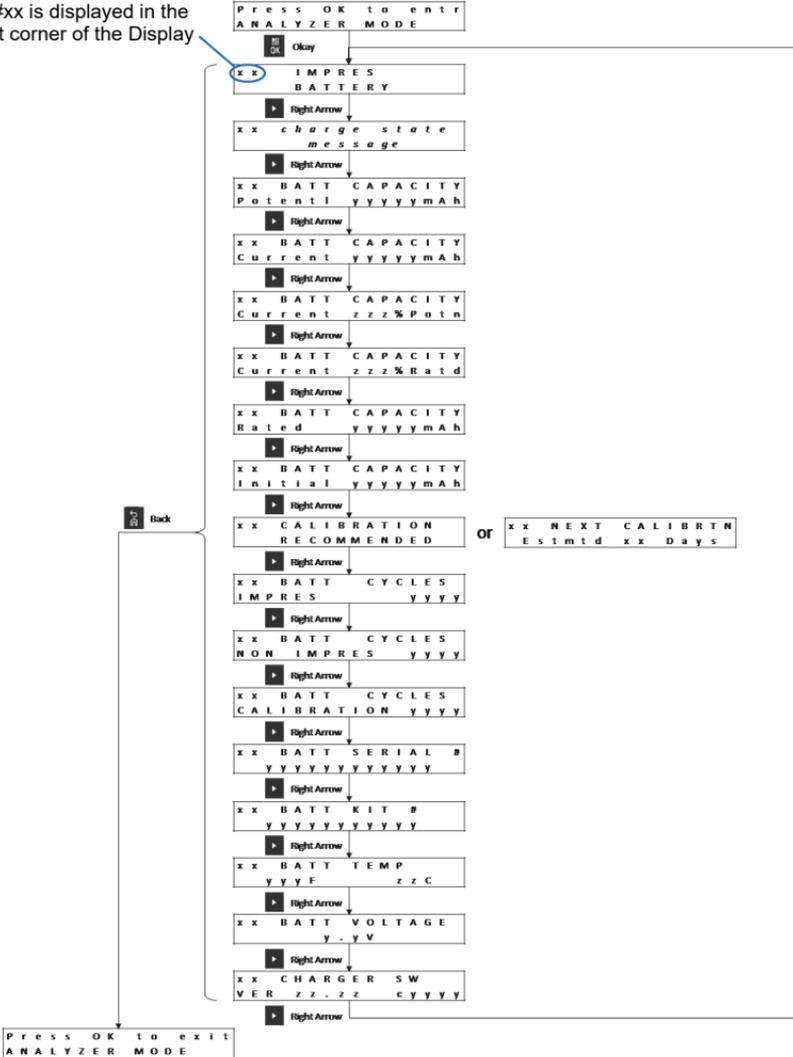
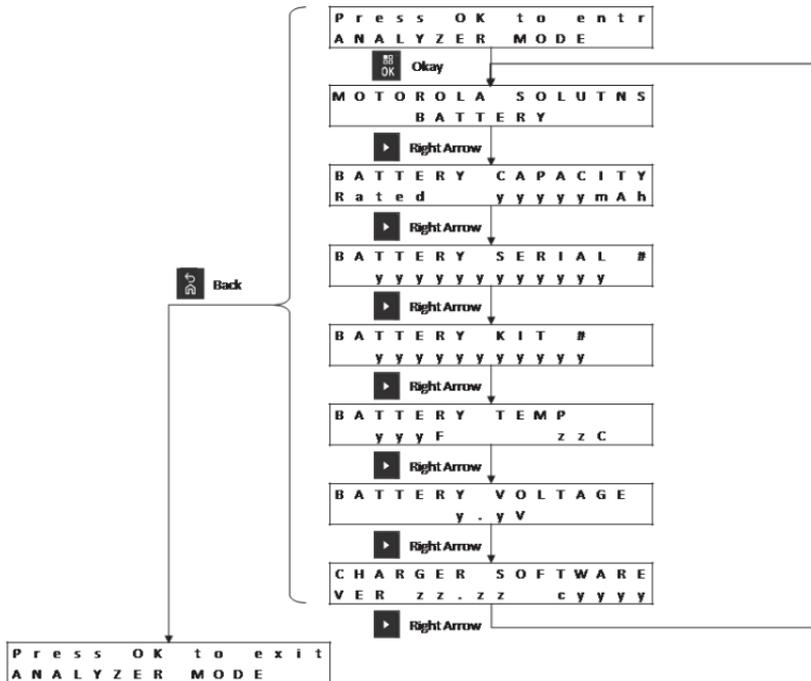

Figure 21: IMPRES Battery Analyzer Mode Menu for Another Pocket (not Pocket #1)

## Other Motorola Solutions Battery

### Display Adjacent to Pocket



**Figure 22:** Other Motorola Solutions Battery Analyzer Mode Menu for Display Adjacent to Pocket

## Pocket #1 Displaying Another Pocket

Pocket #xx is displayed in the upper left corner of the Display

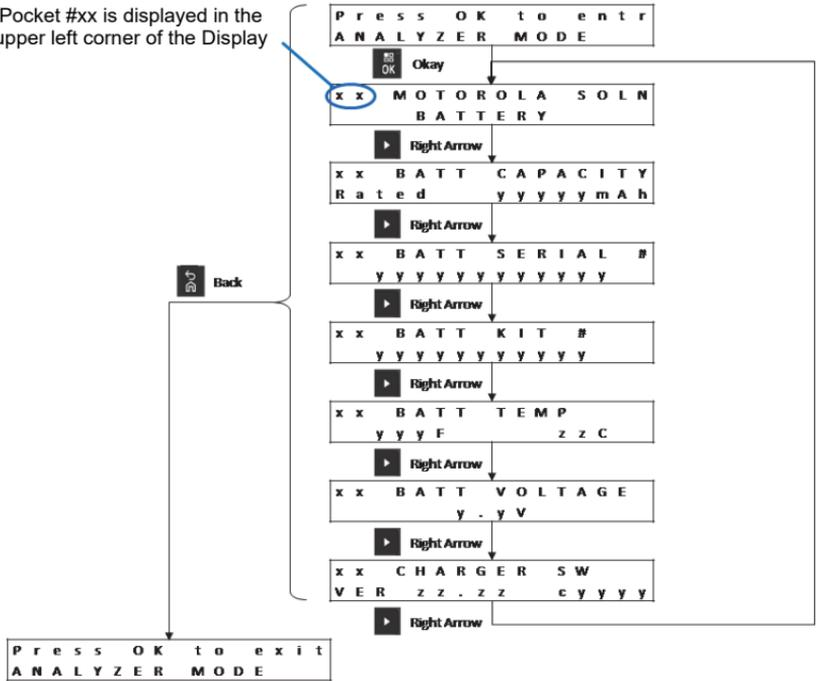
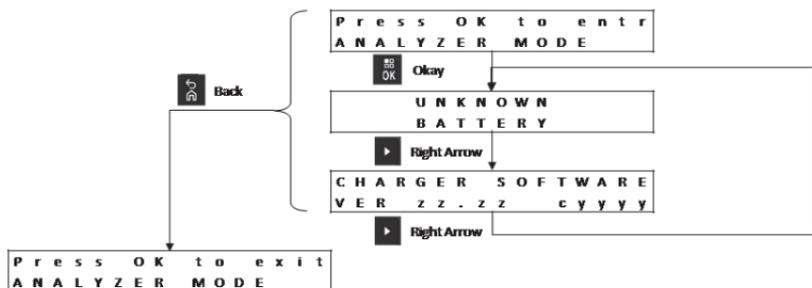

**Figure 23:** Other Motorola Solutions Battery Analyzer Mode Menu for Another Pocket (not Pocket #1)



## Unknown Battery

### Display Adjacent to Pocket



**Figure 24:** Unknown Battery Analyzer Mode Menu for Display Adjacent to Pocket

### Pocket #1 Displaying Another Pocket

Pocket #xx is displayed in the upper left corner of the Display

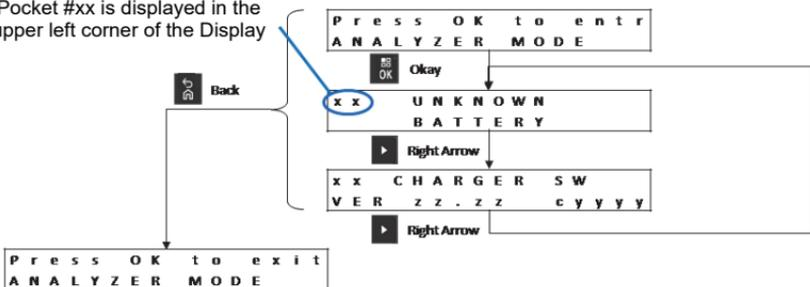

**Figure 25:** Unknown Battery Analyzer Mode Menu for Another Pocket (not Pocket #1)

## Empty Pocket

### Display Adjacent to Pocket

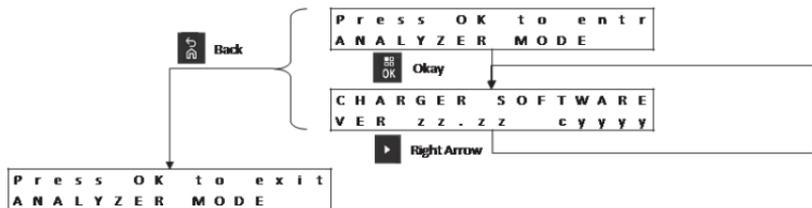

Figure 26: Analyzer Mode Menu for Empty Pocket Adjacent to Display

### Pocket #1 Displaying Another Pocket

Pocket #xx is displayed in the upper left corner of the Display

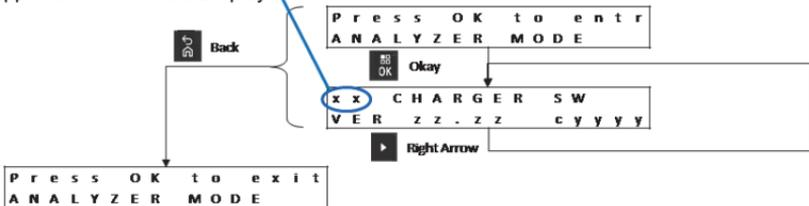

Figure 27: Analyzer Mode Menu for Empty Pocket (not Pocket #1)

## Charger State Message

Some IMPRES 2 batteries are equipped with Sleep mode. At the end of Ship Lithium, xx% Long-Term Storage, or 75% Long-Term Storage, a Sleep-mode-equipped battery is put to sleep. The Charge State Message in Analyzer mode allows you to check the State of Charge of sleeping batteries.

Table 21: Ship Lithium Enabled and the Battery Completed Ship Lithium Charge

Display Adjacent to Pocket	Pocket #1 Displaying Another Pocket
SHIP LI SLEEP xxx% Rated Cap	xx SHIP LI SLEEP xxx% Rated Cap

**Table 22: xx% Long-Term Storage Enabled and the Battery Completed xx% Long-Term Storage Charge**

Display Adjacent to Pocket	Pocket #1 Displaying Another Pocket
STORAGE SLEEP xxx% Rated Cap	xx STORAGE SLEEP xxx% Rated Cap

For example, the Charger State Message is not displayed if xx% Long-Term Storage is enabled and the battery completed 75% Long-Term Storage charge in a different charger.

## Charger Reprogramming

Charger reprogramming requires the Communications Module connected to a computer via a standard USB cable. Using the IMPRES Battery Fleet Management System to initiate charger reprogramming, the following messages are displayed by the charger.

Remove batteries from the charger pockets before reprogramming:

```
REPROGRAMMING
REMOVE BATTERIES
```

All charger pockets are empty:

```
REPROGRAMMING
WAITING FOR DATA
```

Reprogramming data is downloading:

```
REPROGRAMMING
Progress yyy%
```

For chargers with a display associated with each pocket, the percentage value is the percentage of data successfully downloaded into the pocket associated with the display. For chargers that have only one display (Pocket #1), the percentage value is the percentage of data successfully downloaded into all pockets.

Reprogramming failed in the identified pocket:

```
REPROGRAMMING
POCKET#xx FAILED
```

The identified charger pocket starts normal operations using the previous software.

Reprogramming data download is complete. The charging is completing the Reprogramming process.

IMPRES 2  
CHARGER

The Reprogramming process completed successfully.

REPROGRAMMING  
COMPLETE

The charger starts normal operations using the newly-downloaded software. User-defined setting is preserved after charger reprogramming has been completed.

# Charger Troubleshooting

**Table 23:** Troubleshooting: Normal Charging

Issue	What to do...
Pocket LED does not flash Green for approximately 1 second for charger power-on.	Make sure that the power cord is securely plugged into the charge and an appropriate AC power outlet. Make sure that there is power to the outlet. Inspect fuses and replace as necessary.
Battery or radio is inserted into the pocket, but the pocket LED remains OFF and the battery is not identified on the adjacent display.	If the pocket is not Pocket #1 and Power Saver is enabled, press a Menu button. See below.
Flashing Red LED and Display (if available) shows: NOT CHARGEABLE REMOVE & REINSERT or a Motorola Solutions battery is in the pocket, but the Display (if available) shows: UNKNOWN BATTERY 	Remove the battery or radio from the pocket. Check electrical contacts on the battery and in the charger pocket for contamination, corrosion, or physical damage. Verify that the battery is an authorized Motorola Solutions battery. Other batteries may not charge. Clean the battery electrical contacts using a dry cloth. Remove power from the charger, then clean the pocket electrical contacts using a dry cloth. Try replacing the battery. If the fault no longer exists, then take the faulted battery out of service. If the fault persists with the replacement battery, take the charger out of service.
Alternating Red/ Green LED at the end of calibration.  	The IMPRES 2 or IMPRES battery may be nearing End of Service. The battery is usable, however the available capacity may not be suited for heavy use over an extended shift. Applicable only for APX NEXT XN battery: Battery has been exposed to high temperature for more than 10 minutes. It is recommended to remove battery from service.

**Table 23:** Troubleshooting: Normal Charging (Cont.)

Issue	What to do...
Alternating Amber / Green LED for approximately 4 seconds at battery insertion into the charger. 	The IMPRES 2 or IMPRES battery requires Calibration/ Reconditioning. At the next available opportunity, place the battery into an IMPRES 2 charger that has Calibration enabled and allow the charger to complete Calibration (Steady Green).
In Analyzer Mode, Pocket #1 can display another pocket.	The charger is unable to detect the display on at least one of the other pockets.

**Table 24:** Troubleshooting: Long-Term Storage Charge

Issue	What to do...
Flashing Red LED and Display (if available) shows: WRONG BATT TYPE CANNOT LT STORE or CANNOT DISCHARGE CANNOT LT STORE 	Remove the battery from the pocket. Verify that the battery is NOT attached to a radio. Verify that the battery is an IMPRES 2 or IMPRES battery. Other batteries will be faulted. Clean the IMPRES 2 or IMPRES battery electrical contacts using a dry cloth. Remove power from the charger, then clean the pocket electrical contacts using a dry cloth. Try replacing the battery with another IMPRES 2 or IMPRES battery. If the fault no longer exists, then take the faulted IMPRES 2 or IMPRES battery out of service. If the fault persists with the replacement IMPRES 2 or IMPRES battery, take the charger out of service.
Flashing Red LED and Display (if available) shows: STORE INCOMPLETE Low Capacity:yy% 	The Potential Capacity of the IMPRES 2 or IMPRES battery may be less than the Long-Term Storage selection. The battery may be nearing End of Life.

**Table 24:** Troubleshooting: Long-Term Storage Charge (Cont.)

Issue	What to do...
Flashing Red LED and Display (if available) shows: RADIO POCKET CANNOT LT STORE or CHARGING POCKET CANNOT LT STORE	 <p>The charger pocket is not the standard pocket for charging a battery (through electrical contacts between the charger and the battery).</p> <ul style="list-style-type: none"> <li>A Radio Pocket is a special pocket in which the battery is attached to a radio, there are no external contacts on the battery, and the battery is charged through electrical contacts on the radio.</li> <li>A Charging Pocket is a pocket that uses charger energy for a special purpose, such as USB charging ports.</li> </ul> <p>Move the battery to a standard pocket or replace the Radio Pocket or Charging Pocket with a standard pocket.</p>

**Table 25:** Troubleshooting: Ship Lithium Charge

Issue	What to do...
Flashing Red LED and Display (if available) shows: WRONG BATT TYPE CANNOT SHIP LI	 <p>Remove the battery from the pocket. Verify that the battery is NOT attached to a radio.</p> <p>Verify that the battery is an IMPRES 2, IMPRES, or other authorized Motorola Solutions Lithium-Ion battery. Other batteries will be faulted.</p> <p>Clean the IMPRES 2, IMPRES, or other authorized Motorola Solutions Lithium-Ion battery electrical contacts using a dry cloth.</p> <p>Remove power from the charger, then clean the pocket electrical contacts using a dry cloth.</p> <p>Try replacing the battery with another IMPRES 2, IMPRES, or other authorized Motorola Solutions Lithium-Ion battery. If the fault no longer exists, then take the faulted IMPRES 2, IMPRES, or other authorized Motorola Solutions Lithium-Ion battery out of service.</p> <p>If the fault persists with the replacement IMPRES 2, IMPRES, or other authorized Motorola Solutions Lithium-Ion battery, take the charger out of service.</p>
Flashing Red LED and Display (if available) shows: SHIP INCOMPLETE Low Capacity:yy%	 <p>The Potential Capacity of the authentic Motorola Solutions Lithium-Ion battery may be less than the Ship Lithium limit. The battery may be nearing End of Life.</p>

**Table 25: Troubleshooting: Ship Lithium Charge (Cont.)**

Issue	What to do...
<p>Flashing Red LED and Display (if available) shows:</p> <p>RADIO POCKET CANNOT LT STORE</p> <p>or</p> <p>CHARGING POCKET CANNOT SHIP LI</p>	<p>The charger pocket is not the standard pocket for charging a battery (through electrical contacts between the charger and the battery).</p> <ul style="list-style-type: none"><li>• A Radio Pocket is a special pocket in which the battery is attached to a radio, there are no external contacts on the battery, and the battery is charged through electrical contacts on the radio.</li><li>• A Charging Pocket is a pocket that uses charger energy for a special purpose, such as USB charging ports.</li></ul> <p>Move the battery to a standard pocket or replace the Radio Pocket or Charging Pocket with a standard pocket.</p>



## IMPRES Battery Fleet Management System

IMPRES Battery Fleet Management software automatically collects critical data from IMPRES or IMPRES 2 batteries that are inserted into an IMPRES charger. The critical data include battery age, capacity, charge history, Calibration/Reconditioning history, date when manufactured, and date when put into service. IMPRES Battery Fleet Management software analyzes battery data, communicates battery health, and recommends when to replace the battery. As a result, you can quickly and efficiently determine whether or not to redeploy the battery to a less demanding user, when to purchase a new replacement battery, or when to search for a missing battery.

IMPRES Battery Fleet Management delivers battery-critical information:

- When batteries are below an acceptable capacity.
- Helps to ensure users have enough capacity for a full work shift.
- Identifies low-capacity batteries so they can be removed from service.
- Eliminates unexpected downtime and work interruptions.
- Avoids the expense of throwing batteries away prematurely.
- Confirms chargers are optimally distributed and used.

The IMPRES Battery Fleet Management application software is scalable from a single site to a multi-site networked system, as represented in Figure 28. The IMPRES Battery Fleet Management System supports:

- One system Administrator Server
- 19 Remote Clients
- 25 IMPRES Chargers or IMPRES Battery Readers per client
- 25,000 IMPRES Batteries in the same location or over geographically dispersed areas (the total number of batteries for the entire system cannot exceed 25,000).

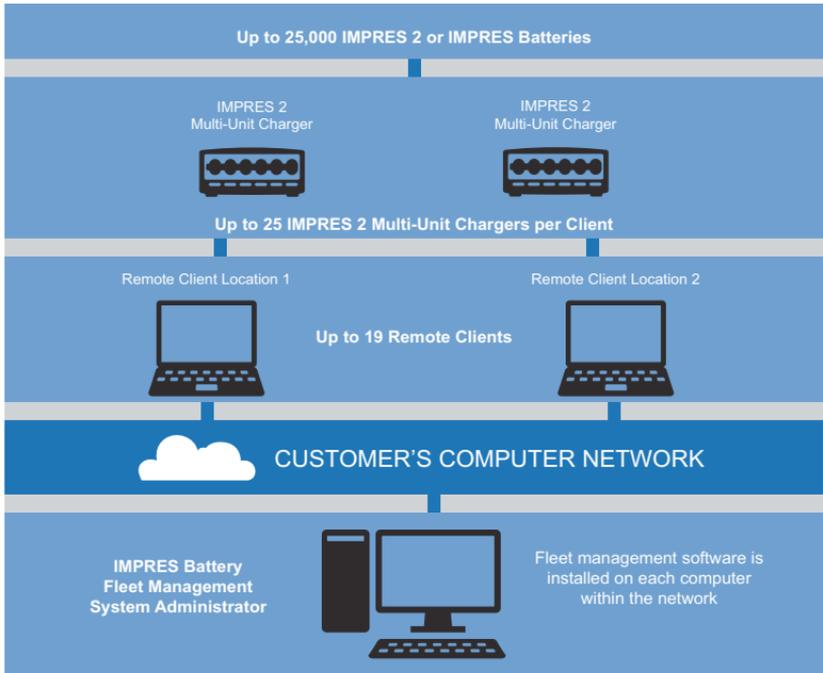

**Figure 28: IMPRES Battery Fleet Management via Network Chargers**  
 IMPRES Battery Fleet Management consists of three major components:

- The application software.
- A software license key.
- A USB cable to connect the IMPRES 2 charger, IMPRES 2 Communications Module, IMPRES Charger Interface Unit (CIU), or IMPRES Battery Data Reader to a computer hosting a Remote Client.

Use existing reports for customize new ones to see the most relevant information for your organization. Data is stored in your database and can be exported to an Excel™ file or printed. IMPRES Battery Fleet Management software records and organizes a variety of data so you can:

- See a status snapshot of your entire battery fleet.
- Evaluate whether batteries are meeting your performance criteria.
- Determine when batteries are nearing their end of life.
- Decided exactly when to buy new batteries.
- Get a lost battery report.
- Optimize your charger utilization.
- Monitor all devices in the system.

Serial Number	Alias	Group	Radio Family	ID Number	Chemistry	IFR	Rated Capacity	Potential Capacity	Date of Next Use
500000E84C9	Sam	Building 1	KTS 5000/2500/2000	HW090118	NCGE	No	1425	1425	8/1/2009
500000E8480	Math	Security	APR	WNTN7972A	NaISe	No	2100	1650	10/15/2008
500000E8488	Michael	Security	APR	WNTN7972A	NaISe	Yes	2000	1400	2/16/2007
500000E8E21	Phil	Administration	HTCG/PRO Series	HW0466A	NCGE	No	1800	1240	3/6/2008
500000CF112	Pat	Building 1	KTS 5000/2500/2000	WNTN4472B	NaISe	Yes	1700	1360	8/14/2008
500000CF488	Steve	Building 2	KTS 2500, HTM/HJ/IR 2500	WNTN7972A	Li-Ion	No	2000	1990	2/6/2008
500000S4881	Active	Home	Seiber	HW06108	NCGE	No	2000	2000	3/5/2009
500000L48173	Nick	Building 2	KTS 2500, HTM/HJ/IR 2500	WNTN7972A	Li-Ion	Yes	1000	1440	8/11/2008
500000B8211	Gene	Building 2	KTS 2500, HTM/HJ/IR 2500	WNTN7972A	Li-Ion	No	2000	1940	9/21/2008
500000S84130	Bob	Home	Seiber	HW06108	NCGE	Yes	2000	2000	10/2/2008
500000CF0211	Carol	Administration	HTCG/PRO Series	HW0466A	NaISe	Yes	1800	1192	11/2/2009
500000L4827	Pat	Building 1	KTS 5000/2500/2000	WNTN7972A	NaISe	Yes	1700	1207	10/21/2008
500000M4360	Ira	Building 1	KTS 5000/2500/2000	HW06118	NCGE	No	1824	1081	8/3/2008
500000S3883	Bill	Security	APR	WNTN7972A	Li-Ion	Yes	4100	2911	7/21/2006
500000S3822	Frank	Security	APR	WNTN7972A	NaISe	No	2100	1491	2/11/2008
500000G4117	Mark	Building 2	KTS 5000/2500/2000	WNTN7435A	Li-Ion	Yes	2900	2804	3/11/2006
500000A2328	PHC	Management	HCTC7R80	PRM0407A	Li-Ion	No	2100	1528	2/28/2008
500000A2329	Steve	Administration	HTCG/PRO Series	HW0466A	NCGE	No	1800	1108	7/10/2008
500000K2841	Phil	Building 1	APR	WNTN7972A	NaISe	No	2100	1491	5/2/2008
500000K2842	Tom	Security	APR	WNTN7972A	Li-Ion	Yes	4100	2911	3/16/2009
500000CF917	Neil	Management	HTCG/PRO Series	HW0466A	NCGE	No	1800	1100	5/5/2009
500000M4211	Steve	Building 2	KTS 5000/2500/2000	PRM0403A	NaISe	No	2000	2070	8/6/2007
500000S4239	Paul	Administration	HCTC7R80	PRM0403A	Li-Ion	Yes	400	869	8/22/2008
500000F4233	Frank	Building 1	APR	WNTN7972A	NaISe	Yes	2000	1300	7/10/2008
500000CF0912	Tom	Security	HCTC7R80	PRM0403A	Li-Ion	Yes	400	866	8/12/2007
500000F0553	Steve	Management	APR	WNTN7972A	NaISe	No	2100	1491	3/1/2008
500000FP416	Seuff	Building 2	HTCG/PRO Series	HW0466A	NaISe	No	1800	1240	10/11/2007
500000F0188	Gary	Security	KTS 5000/2500/2000	WNTN7972A	Li-Ion	Yes	4100	2883	8/6/2008
500000F0223	Bob	Administration	APR	WNTN7972A	NaISe	No	2100	1491	3/17/2008
500000F0781	Mark	Building 1	HCTC7R80	PRM0466A	Li-Ion	No	3000	1033	10/11/2007

Figure 29: Active Battery Report

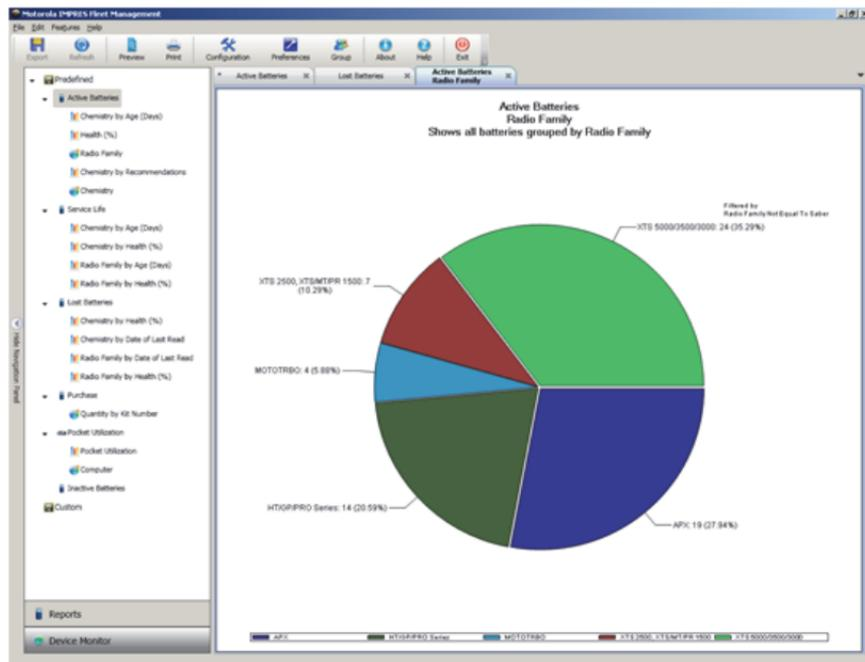

Figure 30: Batteries in Use by Radio Family



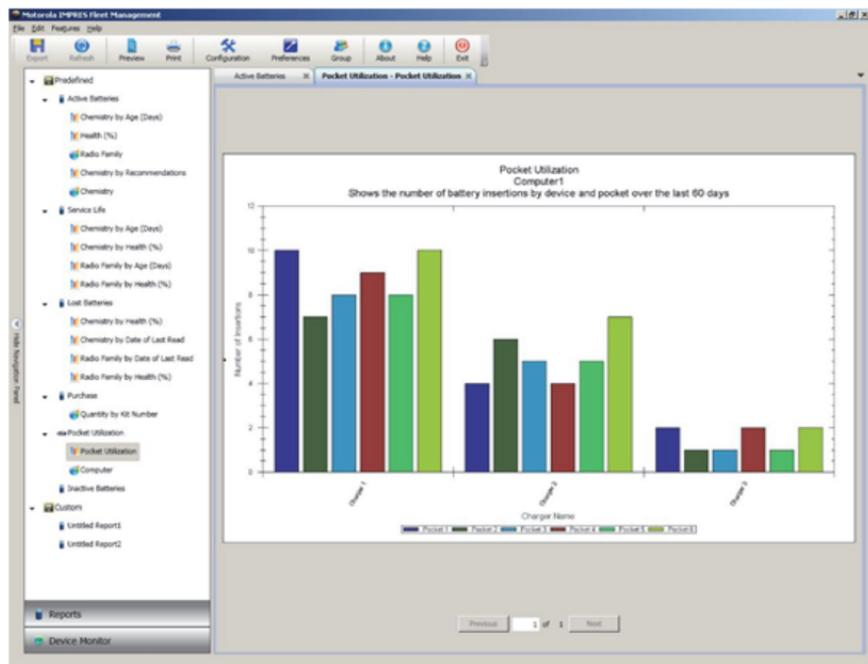

Figure 32: Charger Pocket Utilization

## Multi-Unit Charger Wall Mount

A wall mount bracket (Part Number: 0705559L01) is available for the Multi-Unit Charger. Contact your local dealer to order this item. Installation is shown below.



**WARNING**

- This wall mount bracket must be installed by a trained and experienced technician. Having the product installed by a non specialized technician is very dangerous, and can cause damage or injury.
- Do not install the product where the weight cannot be supported. If the strength of the location where the wall mount is installed is not strong enough, it can fall off and cause an injury.
- Do not install on a structure that is prone to vibration, movement, or chance of impact.

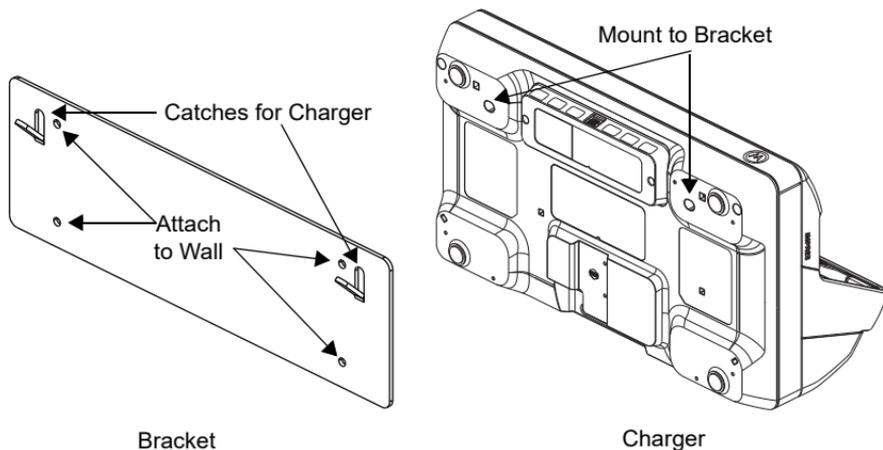

**Figure 33:** Bracket Mounting Holes and Catches Position

## Mounting Multi-Unit Charger to Wall Bracket

1. Position the wall mount bracket in the desired position, and mark the location of the mounting holes on the wall surface.



Caution

Ensure the area behind the mounting surface is always free of electrical wires, cables, and pipes before cutting, drilling, or installing the mounting screws.

2. Mount bracket to wall using the appropriate mounting hardware required for the type of wall material fixture it is being mounted to. Drill based on the marked mounting holes on the wall surfaces.
3. Secure the wall bracket in position by installing mounting hardware over the mounting holes on the wall bracket tightly.

**Note:** It is recommended to use 10-16x1.5 in. tapping screw and washer (not included) on wood stud and solid-flat concrete/brick wall.

4. Hang the Multi-Unit Charger on the wall bracket.

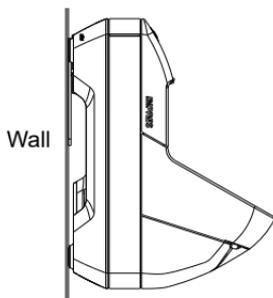

**Figure 34:** Charger Mounted on Wall Bracket



## Notes

# INSTRUCTIONS DE SÉCURITÉ IMPORTANTES

## Conserver ces instructions

Ce document contient d'importantes directives relatives à la sécurité et au fonctionnement de l'appareil. Veuillez lire attentivement cette notice et la conserver pour vous y référer ultérieurement.

Avant d'utiliser le chargeur de batterie, lisez toutes les directives et les marquages d'avertissement sur (1) le chargeur, (2) la batterie et (3) la radio associée à la batterie.



AVERTISSEMENT

1. Afin de réduire la possibilité d'endommager le cordon d'alimentation, tirez sur la prise et non sur le cordon au moment de le débrancher de la prise c.a. ou du chargeur.
2. Il n'est pas recommandé d'utiliser une rallonge, sauf en cas de nécessité absolue. L'utilisation d'une rallonge inappropriée pourrait causer un risque d'incendie et de décharge électrique. Si une rallonge doit être utilisée, assurez-vous que le format du cordon est de calibre 18 lorsque sa longueur est de 2 m (6,5 pieds) ou moins et de calibre 16 lorsque sa longueur est de 3 m (9,8 pieds) ou moins.
3. Pour réduire le risque d'incendie, de décharge électrique ou de blessure, n'utilisez pas le chargeur s'il est brisé ou endommagé de quelque manière que ce soit. Portez-le chez un représentant de service Motorola Solutions.
4. Ne désassemblez pas le chargeur. Le désassemblage du chargeur pourrait occasionner des risques de décharge électrique ou d'incendie. Les seules pièces réparables ou remplaçables sont les garnitures des logements NNTN9212 et NNTN9213. Suivez les instructions fournies avec les trousse de garnitures de logement pour multichargeurs IMPRES 2 de série APX (MN005697A01).
5. Pour réduire les risques de décharge électrique, débranchez l'alimentation du chargeur de la prise c.a. avant de procéder à une maintenance ou à un nettoyage.



6. Afin de réduire les risques de blessure, ne chargez que les batteries rechargeables approuvées par Motorola Solutions apparaissant dans le Tableau 2. Les batteries non approuvées pourraient exploser et causer des blessures corporelles et d'autres dommages.
7. L'utilisation d'accessoires non recommandés par Motorola Solutions pourrait occasionner des risques d'incendie, de décharge électrique ou de blessure.

## Directives d'utilisation sécuritaire

- Cet équipement n'est pas conçu pour une utilisation à l'extérieur. Ne l'utilisez que dans des emplacements secs et sous des conditions sans risque d'humidité.
- La température ambiante maximale autour du chargeur ne doit pas dépasser 40 °C (104 °F).
- Lorsqu'une radio est dans un logement du chargeur, elle ne peut être activée que si elle transmet des données sans fil, comme lorsqu'elle utilise un réseau Wi-Fi. Dans le cas contraire, éteignez la radio.
- Branchez le chargeur uniquement à un bloc d'alimentation approprié, comme indiqué dans le Tableau 3.
- La prise de courant à laquelle le cordon d'alimentation est branché doit se trouver à proximité et être facilement accessible.
- Assurez-vous que le cordon du bloc d'alimentation est placé à un endroit où il ne sera pas écrasé ou endommagé, ne gênera pas le passage, ne sera pas trop tendu et ne sera pas exposé à une source d'humidité.
- Ne branchez le cordon d'alimentation qu'à une prise à fusible câblée appropriée et de tension prescrite comme spécifiée sur le produit.
- Débranchez le chargeur de la tension de secteur en retirant le cordon d'alimentation de la prise de courant.
- Ne branchez pas plus de chargeurs que le nombre approprié à un circuit de 15 A ou 20 A, selon la limite indiquée pour toute barre d'alimentation certifiée utilisée. La configuration en guirlande de barres d'alimentation n'est PAS RECOMMANDÉE. Limitez la charge du circuit à 80 % de sa valeur nominale.
- Utilisez uniquement les logements approuvés par Motorola Solutions.

## Modèles pris en charge

**Tableau 1 : Modèles pris en charge et description**

Modèle	Description
PS000029A01 (UNIV) PS000029A04 (UE/RU) PS000029A06 (RK)	Multichargeur APX IMPRES 2 à un seul écran avec reprogrammation de chargeur et Battery Fleet Management
PS000029A02 (UNIV) PS000029A05 (UE/RU) PS000029A07 (CO)	Multichargeur APX IMPRES 2 à six écrans avec reprogrammation de chargeur et Battery Fleet Management
PS000029A03 (UE/RU) PS000029A08 (CO)	Multichargeur APX IMPRES 2 à six écrans avec reprogrammation de chargeur, Battery Fleet Management et charge d'accessoires USB
PS000337A01 (ÉU/AN, AU/NZ)	Multichargeur APX NEXT IMPRES 2 à six écrans avec reprogrammation de chargeur et Battery Fleet Management

## Batteries approuvées par Motorola Solutions

Les chargeurs de série APX IMPRES 2 peuvent charger les batteries répertoriées dans le Tableau 2. Les batteries peuvent être branchées à une radio ou autonomes.

**Tableau 2 : Batteries approuvées par Motorola Solutions**

Trousse (n° pièce)	Description
NNTN7033	IMPRES au lithium-ion FM (pour emplacements dangereux) IP67 4100 mAh
NNTN7034	IMPRES au lithium-ion IP67 4200 mAh
NNTN7035	IMPRES NiMH FM robuste (pour emplacements dangereux) 2000 mAh
NNTN7036	IMPRES NiMH FM (pour emplacements dangereux) IP67 2000 mAh
NNTN7037	IMPRES NiMH IP67 2100 mAh
NNTN7038	IMPRES au lithium-ion IP67 2900 mAh
NNTN7573	IMPRES NiMH robuste 2100 mAh
NNTN8092	IMPRES au lithium-ion FM robuste (pour emplacements dangereux) 2300 mAh
NNTN8182	IMPRES au lithium-ion robuste 2900 mAh

**Tableau 2 : Batteries approuvées par Motorola Solutions (suite)**

<b>Trousse (n° pièce)</b>	<b>Description</b>
NNTN8921	IMPRES 2 au lithium-ion robuste TIA4950 (pour emplacements dangereux) IP67 3700 mAh
NNTN8930	IMPRES 2 au lithium-ion robuste TIA4950 (pour emplacements dangereux) IP67 2700 mAh
NNTN9087	IMPRES 2 au lithium-ion IP68 3800 mAh
NNTN9088	IMPRES 2 au lithium-ion DIVISION 2 (pour emplacements dangereux) IP68 3800 mAh
NNTN9089	IMPRES 2 au lithium-ion IP68 5650 mAh
NNTN9090	IMPRES 2 au lithium-ion DIVISION 2 (pour emplacements dangereux) IP68 5650 mAh
NNTN9126	IMPRES 2 au lithium-ion IP68 4400 mAh
NNTN9127	IMPRES 2 au lithium-ion DIVISION 2 (pour emplacements dangereux) IP68 4400 mAh
PMNN4403	IMPRES au lithium-ion IP67 2150 mAh
PMNN4485	IMPRES 2 au lithium-ion robuste IP67 2500 mAh
PMNN4486	IMPRES 2 au lithium-ion robuste IP67 3400 mAh
PMNN4487	IMPRES 2 au lithium-ion robuste IP67 4400 mAh
PMNN4494	IMPRES 2 au lithium-ion robuste IP67 5000 mAh
PMNN4504	IMPRES 2 au lithium-ion DIVISION 2 robuste (pour emplacements dangereux) IP67 3400 mAh
PMNN4505	IMPRES 2 au lithium-ion DIVISION 2 robuste (pour emplacements dangereux) IP67 4850 mAh
PMNN4547	IMPRES 2 au lithium-ion robuste TIA4950 (pour emplacements dangereux) IP68 3100 mAh
PMNN4573	IMPRES 2 au lithium-ion robuste TIA4950 (pour emplacements dangereux) IP68 4600 mAh
PMNN4812	APX NEXT XN IMPRES 2 au lithium-ion DIV 2 (HAZLOC) IP68 3400 mAh

# Blocs d'alimentation approuvés par Motorola Solutions

Tableau 3 : Blocs d'alimentation approuvés par Motorola Solutions

Trousse (n° pièce)	Description
3087791G01	Cordon d'alimentation, ÉU/AN
3087791G04	Cordon d'alimentation, UE
3087791G07	Cordon d'alimentation, RU/HK
3087791G10	Cordon d'alimentation, AU/NZ
3087791G13	Cordon d'alimentation, AR
3087791G16	Cordon d'alimentation, KR
3087791G20	Cordon d'alimentation, JP
3087791G22	Cordon d'alimentation, BR
CB000460A01	Cordon d'alimentation, CH

## Modules de communication approuvés par Motorola Solutions

Tableau 4 : Modules de communication approuvés par Motorola Solutions

Trousse (n° pièce)	Description
AS000013A01	Module de Battery Fleet Management et de reprogrammation de chargeur IMPRES 2
AS000012A02	Module de Battery Fleet Management et de reprogrammation de chargeur IMPRES 2 et module de chargement d'accessoire

## Chargeur, logement et module de communication

Le système de chargeur adaptatif IMPRES 2™ de la série APX est un système d'entretien de batterie entièrement automatisé. Le chargeur comprend les caractéristiques suivantes :

- Charge adaptative pour convenir à un large éventail de types de batteries, y compris les batteries IMPRES 2 et IMPRES™, et d'autres batteries Motorola Solutions d'origine.
- Logement pouvant accueillir une batterie autonome ou une radio avec sa batterie.

- État du logement du chargeur indiqué par un voyant rouge/ambre/vert.
- Module de communication
  - Reprogrammation du chargeur
  - Chargement de données de batterie IMPRES 2 ou IMPRES dans un système Battery Fleet Management IMPRES
  - (En option) Six ports de chargement USB de type A, chacun avec 0,5 A pour le chargement d'un accessoire USB
- Menu clavier
  - Configuration du chargeur
  - Analyse de batterie
- Affichage de renseignements sur le logement n° 1
  - Écrans sur les autres logements en option
- Préparation d'une batterie IMPRES 2 ou IMPRES autonome pour le stockage à long terme ou préparation d'une batterie au lithium-ion autonome de Motorola Solutions pour l'expédition. **NE LAISSEZ PAS** les batteries dans le chargeur une fois que la préparation pour le stockage à long terme ou l'expédition de batterie au lithium-ion est terminée.
- Fonctionnalités d'efficacité énergétique
  - Conforme aux normes pour les appareils de la California Energy Commission pour les petits systèmes de chargement de batterie. Les logements seront mis en veille automatiquement, puis se réactivent pour répondre à une action de l'utilisateur ou pour charger une batterie dans le logement.
  - Conforme aux limites européennes de consommation en mode veille (trousse de chargeur européenne). Lorsque le mode d'économie d'énergie est activé, tous les logements du chargeur, sauf le logement n° 1, s'éteignent automatiquement lorsque aucune activité est détectée pendant un certain temps. Appuyer sur une touche du clavier réactive ces logements.
- Charge plus rapide des batteries au lithium-ion IMPRES 2.
- Charge plus rapide.
- Prolongation du cycle de vie de la batterie.

L'utilisation de la radio alors qu'elle est insérée dans le chargeur n'est pas recommandée.

Pendant le processus de charge, l'utilisation de la radio peut entraîner une réduction de la performance de la radio et la prolongation du temps de charge de la batterie.

Durant l'étalonnage/remise en état, la batterie est complètement déchargée avant d'être complètement chargée. Par conséquent, la radio peut s'éteindre au cours de la phase de déchargement. Il est recommandé de calibrer la batterie sans la radio, ou avec la radio éteinte.

## **Chargeurs et batteries IMPRES 2 et IMPRES**

### **Caractéristiques et avantages**

La solution énergétique IMPRES 2 est un système de gestion avancé de l'énergie à triple chimie développé par Motorola Solutions.

Ce système comprend :

- les batteries IMPRES 2 et IMPRES;
- le chargeur adaptatif IMPRES 2;
- les radios IMPRES.

La charge des batteries IMPRES 2 ou IMPRES à l'aide d'un chargeur adaptatif IMPRES 2, qui procède périodiquement à l'étalonnage et à la remise en état de la batterie, offre les avantages suivants :

- Prolongation du cycle de vie de la batterie.
- Mesure de la capacité de la batterie et détermination de l'état de charge actuel, ce qui vous donne une indication de son temps d'utilisation utile.
- Surveillance du schéma d'utilisation de la batterie IMPRES 2 ou IMPRES.
- Mise à jour de l'information sur le schéma stocké dans la batterie IMPRES 2 ou IMPRES.
- Étalonnage/remise en état automatique au besoin seulement.
- Minimisation de la chauffe de la batterie IMPRES 2 ou IMPRES, peu importe la durée pendant laquelle la batterie est laissée dans le logement.
- Achèvement de la charge périodique d'une batterie dans le logement, maintenant un état de charge élevée et prête pour l'utilisateur.



- Élimination de l'effet de mémoire de la batterie au nickel, ce qui élimine le besoin d'acheter un équipement spécial ou de former le personnel à des tâches pour maintenir le cycle de vie des batteries.

En utilisant ce système breveté unique, il n'est plus nécessaire de suivre et d'enregistrer l'utilisation des batteries IMPRES 2 ou IMPRES, de procéder à des cycles de remise en état ou d'étalonnage manuels, ou de retirer les batteries des chargeurs une fois la charge complétée.

## **Initialisation de la batterie IMPRES 2 ou IMPRES**

Pour la pleine fonctionnalité IMPRES 2 ou IMPRES, une nouvelle batterie IMPRES 2 ou IMPRES doit être initialisée par le chargeur. Le chargeur détecte automatiquement la nouvelle batterie IMPRES 2 ou IMPRES et commence automatiquement l'initialisation. L'initialisation constitue le premier étalonnage ou la première remise en état d'une batterie IMPRES 2 ou IMPRES. Ceci est un processus en deux phases. La première phase est la décharge de la batterie, indiquée par un voyant **ambre fixe**. La deuxième phase consiste en une pleine charge, éventuellement indiquée par un voyant **vert fixe**. Ce processus peut prendre jusqu'à 12 heures ou plus, en fonction de l'état de charge et de la capacité nominale de la batterie. L'interruption d'une des phases retarde l'initialisation jusqu'à la prochaine occasion de charge.

## **Batterie IMPRES 2 ou IMPRES de logement à logement**

Lors de la charge de batteries IMPRES 2 ou IMPRES, le chargeur IMPRES 2 ou IMPRES enregistre l'information sur la charge dans la mémoire de la batterie. Si la batterie IMPRES 2 ou IMPRES est retirée d'un logement du chargeur IMPRES 2 ou IMPRES, puis insérée dans les 30 minutes dans le même ou un autre logement du chargeur IMPRES 2 ou IMPRES, la charge reprend alors au point où elle a été interrompue. Cette fonctionnalité empêche la surcharge de la batterie et minimise la perte du cycle de vie. Ceci est particulièrement important lors de la charge de batteries au nickel.

## **Étalonnage/remise en état automatique de la batterie IMPRES 2 ou IMPRES**

Le chargeur IMPRES 2 évalue automatiquement l'état d'une batterie IMPRES 2 ou IMPRES. En fonction de cet état, le chargeur étalonne/remet en état automatiquement la batterie. L'interruption de la phase de décharge ou de charge complète retarde l'étalonnage jusqu'à la prochaine occasion de chargement.

Utilisez le mode de configuration du chargeur pour activer ou désactiver l'étalonnage et la remise en état. Lorsque cette fonction est désactivée et que la batterie IMPRES 2 ou IMPRES doit être étalonnée/remise en état, le voyant **clignote en alternance ambre/vert** lorsque la batterie est insérée et une fois la batterie chargée.

**Remarque :** La batterie IMPRES 2 ou IMPRES doit être à l'extérieur du logement du chargeur pendant plus de 30 minutes pour effectuer l'étalonnage ou la remise en état automatique.

## La batterie IMPRES avec étalonnage et remise en état automatique



**ATTENTION :** Les batteries IMPRES 2 qui ont cette icône sur l'étiquette de la batterie ne nécessitent pas d'étalonnage et de remise en état périodiques lorsqu'elles sont chargées dans ce chargeur IMPRES 2 (avec la version du logiciel V2.05 ou une version plus récente).

**Remarque:** Assurez-vous que votre chargeur est toujours mis à jour avec le micrologiciel le plus récent. Le progiciel d'application du reprogrammeur de chargeur MSI peut être téléchargé à partir de Motorola Online (MOL) ou du site Web de Motorola Solutions.

## Mise à jour du micrologiciel

**Remarque:** S'applique à tous les appareils ou chargeurs Gen 1 et Gen 2 D'IMPRES, incluant l'unité d'interface de chargeur (CUI), le lecteur de données de batterie (BDR), le chargeur à unité simple (SUC), le chargeur d'unités doubles (DUC) et le multichargeur (MUC).

Retirez toutes les batteries insérées de l'appareil ou du chargeur cible avant de mettre à niveau un appareil OU un chargeur IMPRES à une version plus récente.

1. Connectez l'appareil ou le chargeur à votre ordinateur à l'aide d'un port USB. L'appareil ou le chargeur connecté est indiqué dans la fenêtre principale du reprogrammeur de chargeur MSI.

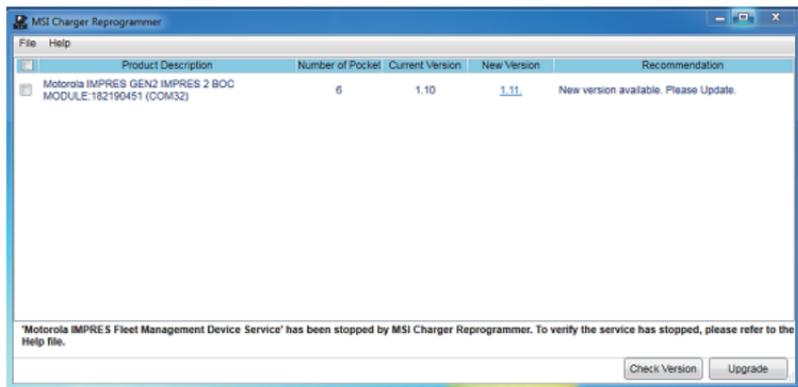

2. Cliquez sur Check Version (Vérifier la version) pour trouver la version la plus récente disponible à partir du serveur MSI.

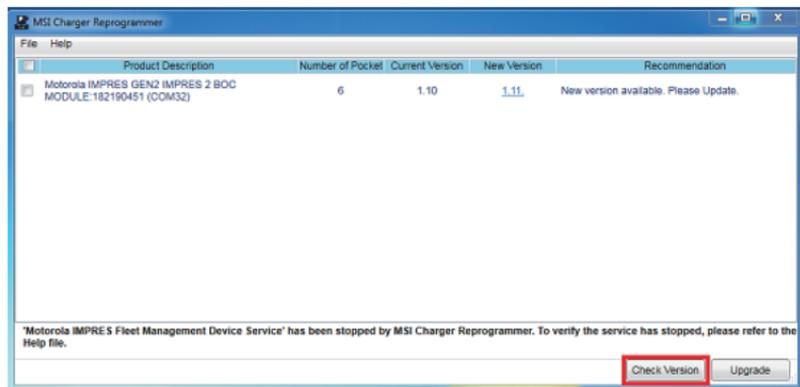

3. Sélectionnez l'appareil ou le chargeur qui doit être mis à jour.

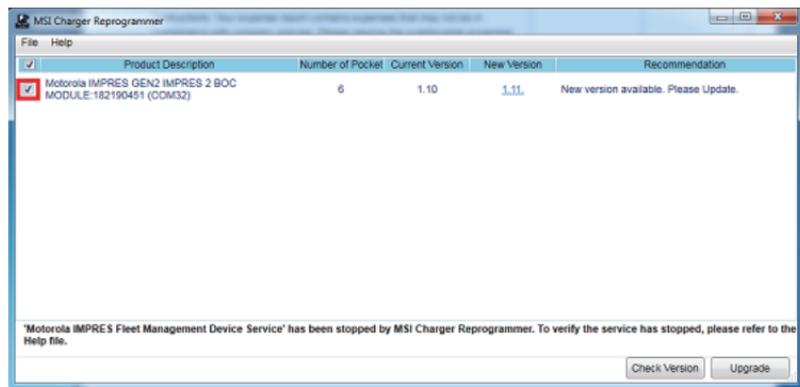

**Remarque:** Vous ne pouvez pas sélectionner un appareil ou un chargeur déjà mis à jour avec la dernière version du micrologiciel.

4. Pour lancer la mise à niveau du micrologiciel, cliquez sur Upgrade (Mise à niveau).

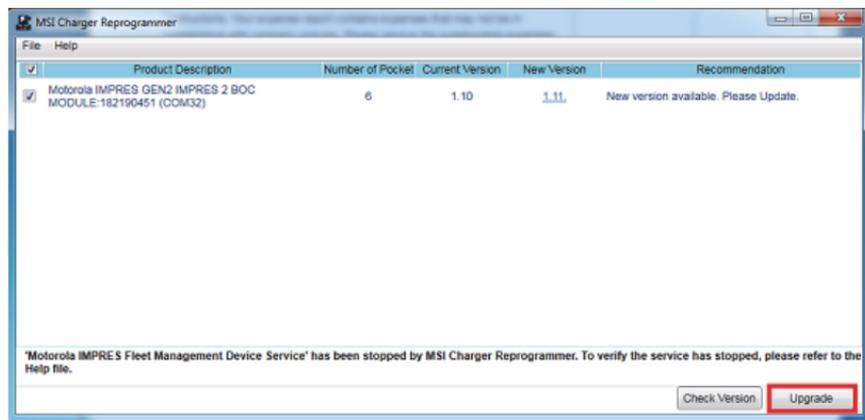

5. Cliquez sur OK dans la fenêtre de confirmation lorsque vous êtes invité à commencer la mise à niveau. Une fenêtre indique la progression de la mise à niveau jusqu'à ce qu'elle soit terminée.

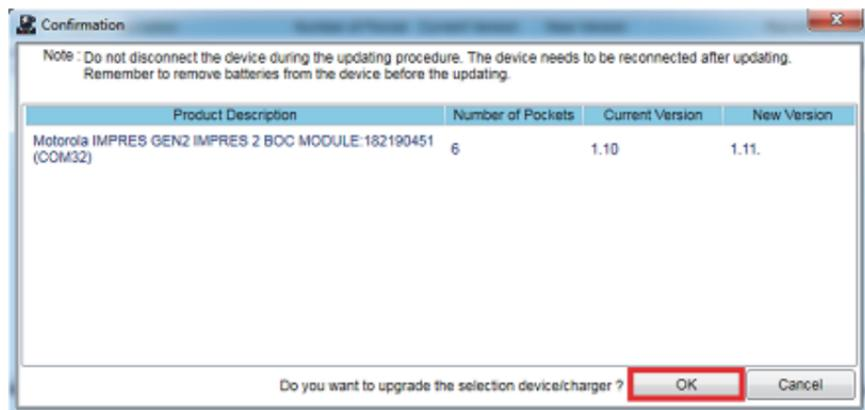

6. Fermez la fenêtre une fois toutes les mises à niveau terminées.

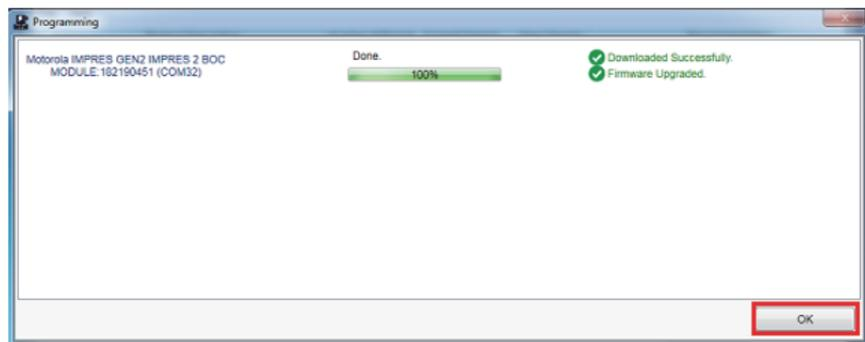

## Initiation manuelle de l'étalonnage/remise en état



**ATTENTION** : L'étalonnage manuel ou la remise en état ne s'applique pas aux batteries IMPRES ou IMPRES 2 qui sont munies de cette icône.

Bien que l'étalonnage/remise en état soit automatique, il peut y avoir des situations où l'initiation manuelle est souhaitée. Par exemple, le voyant du chargeur peut **clignoter en alternance ambre/vert** pour la batterie IMPRES 2 ou IMPRES parce que l'étalonnage est désactivé dans le chargeur. Si, dans les 30 minutes suivantes, cette batterie est insérée dans un chargeur dont la fonction d'étalonnage est activée, le dernier état de charge se poursuit, ce qui empêche l'activation automatique de l'étalonnage ou de la remise en état.

Pour lancer manuellement l'étalonnage ou la remise en état, assurez-vous que la batterie IMPRES 2 ou IMPRES est retirée du chargeur pendant plus de deux minutes et demie. Procédez ensuite aux étapes suivantes :

1. Insérez la batterie dans le logement du chargeur.
2. Dans les 2,5 minutes, retirez la batterie du logement du chargeur.
3. Dans les 5 secondes, réinsérez la batterie dans le logement du chargeur.

L'étalonnage/remise en état démarre immédiatement, en commençant habituellement par la décharge de la batterie (**ambre fixe**).

L'étalonnage/remise en état est seulement achevé après une charge complète (**vert fixe**).

### **Mettre fin manuellement à l'étalonnage/remise en état**

En tout temps au cours du déchargement de la batterie IMPRES 2 ou IMPRES (ambre fixe), vous pouvez mettre fin à l'étalonnage/la remise en état en suivant ces étapes :

1. Retirez la batterie du logement du chargeur.
2. Dans les 5 secondes, réinsérez la batterie dans le logement du chargeur.

Le déchargement de la batterie se termine immédiatement, et le chargement normal de la batterie démarre. Le voyant indique l'état de charge.

## Présentation du chargeur

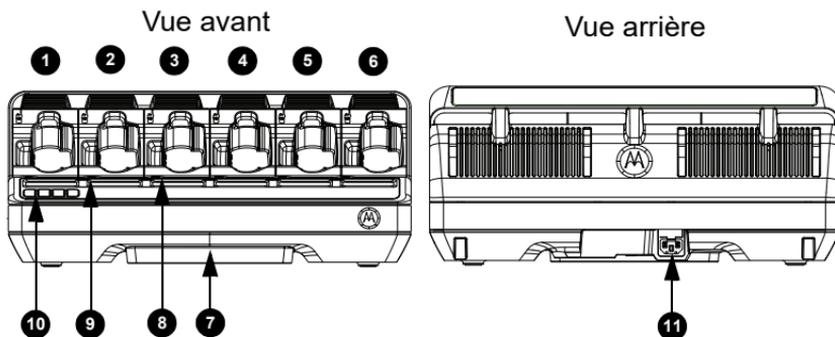

Figure 1 : Présentation du chargeur

Tableau 5 : Présentation et description du chargeur

N°	Nom	Description
1 à 6	Logements du chargeur	Chaque logement peut accueillir une radio compatible ou une batterie autonome
7	Module de communication	Dans certains chargeurs, le module de communication charge également les accessoires USB : <ul style="list-style-type: none"> <li>• UE/RU PS000029A03</li> <li>• RK PS000029A08</li> </ul>
8	Voyant d'indication d'état du logement	Voyant d'état de charge (un par logement)
9	Écran	Écran en option pour les logements autres que le logement n° 1
10	Écran du clavier	Écran du logement n° 1 avec clavier du menu
11	Connecteur d'entrée c.a.	Utilisez le cordon approprié en fonction de votre pays ou région

## Indication de la fin du cycle de vie de la batterie IMPRES 2 ou IMPRES

Le chargeur peut indiquer que la batterie IMPRES 2 ou IMPRES a atteint la fin de son cycle de vie (**alternance rouge/vert**) lorsque l'opération d'étalonnage/remise en état s'est achevée avec succès.

Au fil de l'utilisation des batteries, l'usure normale réduit la capacité disponible. Une fois un cycle d'étalonnage/remise en état achevé, le chargeur compare la capacité de la batterie IMPRES 2 ou IMPRES à la capacité nominale indiquée pour cette batterie. En présence d'une très faible valeur de capacité, il est possible que la batterie IMPRES 2 ou IMPRES soit proche de la fin de son cycle de vie. La batterie IMPRES 2 ou IMPRES reste utilisable. Dans certains cas, il peut être souhaitable de donner la batterie à une personne qui n'a pas besoin d'une grande capacité de batterie pour son quart de travail.

La batterie APX NEXT XN comprend une fonction de détection de température élevée qui est détectable à partir du chargeur IMPRES 2 avec le logiciel version V2.05 ou plus récente. Lorsque cette fonction est activée, le voyant d'état DEL clignote en rouge et vert en alternance lorsque la charge d'une batterie qui a reçu une exposition prolongée dans des conditions de température très élevée est complétée. Le chargeur affiche le message suivant :

REPLACE BATTERY  
EXPOSED OVERTEMP

Il est recommandé de retirer cette batterie du service.

## Chargement des batteries ou des radios avec batterie installée

Pour des résultats optimaux, chargez la batterie à la température ambiante. Les multichargeurs IMPRES 2 peuvent charger une batterie autonome ou une batterie reliée à une radio.

1. Déposez le chargeur sur une surface plane.
2. Insérez fermement le cordon d'alimentation dans le connecteur d'entrée c.a. à l'arrière du chargeur.
3. Branchez le cordon d'alimentation à une prise de courant appropriée.
4. Après la mise sous tension, les voyants d'état de charge clignotent en **vert** pendant environ une seconde et `IMPRES 2 CHARGER` s'affiche. Si les voyants d'état de charge ne clignotent pas et aucun message ne s'affiche, vérifiez les branchements du cordon d'alimentation.



5. Insérez la radio avec la batterie ou la batterie seule dans un logement disponible.

**Remarque :** Tenez le boîtier de la radio lors de son insertion ou de son retrait du chargeur. Évitez de tirer sur l'antenne de la radio.

6. Lorsque la radio ou la batterie autonome est correctement insérée dans le logement, l'état de charge est indiqué par le voyant d'état du logement associé. L'écran associé fournit des informations supplémentaires. Dans le cas des chargeurs à un seul écran, celui-ci indique uniquement l'état de charge du logement n° 1.
7. La batterie est prête à l'emploi lorsque l'état de charge passe au **vert fixe**.
8. Allumez la radio seulement lorsque le module de communication du chargeur n'est pas relié à un ordinateur. Dans le cas contraire, éteignez la radio ou l'appareil.

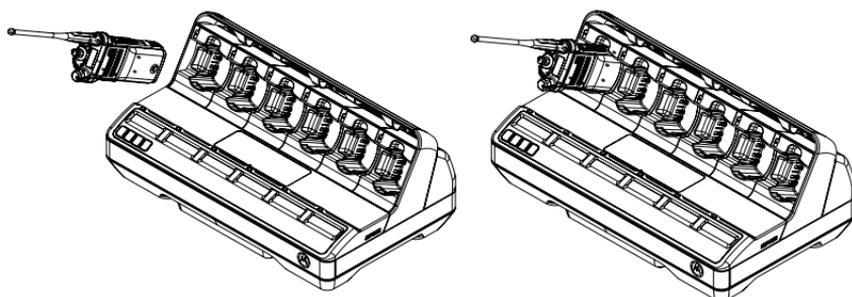

**Figure 2 :** Charger une batterie reliée à la radio

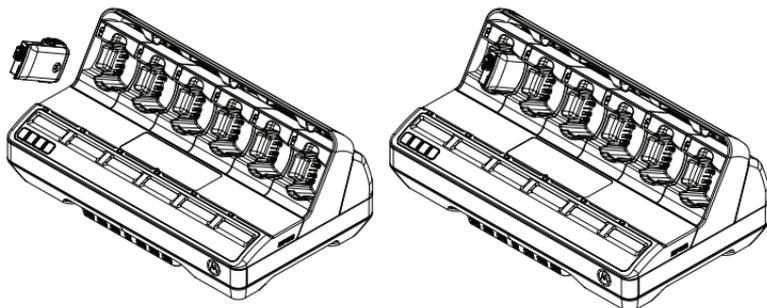

**Figure 3 :** Charger une batterie autonome

## Charger des accessoires USB

Certains modules de communication de multichargeur IMPRES 2 offrent des ports USB de type A pour charger les accessoires USB. Pour des résultats optimaux, chargez les accessoires USB à la température ambiante.

1. Placez le chargeur adaptatif IMPRES 2 sur une surface plane.
2. Insérez fermement le cordon d'alimentation dans le connecteur d'entrée c.a. à l'arrière du chargeur.
3. Branchez le cordon d'alimentation à une prise de courant appropriée.
4. Après la mise sous tension, les voyants d'état de logement clignotent en **vert** pendant une seconde et **IMPRES 2 CHARGER** s'affiche. Si les voyants d'état ne clignotent pas et qu'aucun message ne s'affiche, vérifiez les branchements du cordon d'alimentation.
5. Un accessoire USB peut avoir un réceptacle micro-AB pour le chargement. Utilisez un câble USB standard de 1 m ou plus court avec une prise de type A à une extrémité et une prise compatible avec l'accessoire à l'autre extrémité (habituellement micro-B ou micro-AB).
6. Orientez la prise USB de type A du câble sur le port de type A du module de communication. Branchez la fiche dans le port.
7. Orientez la prise USB de type B du câble sur le réceptacle micro-AB de l'accessoire USB. Branchez la prise dans le port.
8. Lorsque les connexions USB sont correctement insérées, l'état de charge est indiqué par l'accessoire USB. Consultez le guide de l'utilisateur de l'accessoire USB pour plus de détails.

## Indications de charge

**Tableau 6** : Indications de charge d'une batterie IMPRES 2 ou IMPRES – étalonnage non requis

État	Écran du logement	Voyant lumineux
Mise sous tension du chargeur	IMPRES 2 CHARGER	Vert pendant environ une seconde 
Batterie détectée	IMPRES 2 BATTERY OU IMPRES BATTERY	Rouge fixe 

**Tableau 6** : Indications de charge d'une batterie IMPRES 2 ou IMPRES – étalonnage non requis (suite)

État	Écran du logement	Voyant lumineux
Charge rapide	RAPID CHARGE XXXX0mAh yyy%Pt1	Rouge fixe 
Charge à 90 % ou plus	TRICKLE CHARGE xxxx0mAh yyy%Pt1	Vert clignotant 
Charge à 95 % ou plus	CHARGE COMPLETE xxxx0mAh yyy%Pt1	Vert fixe 
Défaillance	WARNING: NOT CHARGEABLE REMOVE & REINSERT	Rouge clignotant 
Veille • La batterie est en attente de charge rapide. • La batterie est trop chaude ou trop froide, ou sa tension est faible. • Le chargeur est trop chaud.	WARNING: HOT BATTERY WAITING TO CHARGE OU COLD BATTERY WAITING TO CHARGE OU VERY LOW BATTERY WAITING TO CHARGE OU HOT CHARGER WAITING TO CHARGE	Ambre clignotant 

**Remarque :**

- Le message **Hot Charger** a été ajouté dans la version V1.05 du logiciel.
- Les indications relatives à l'état du chargeur en pourcentage, fondées sur le rapport entre la capacité potentielle et la capacité nominale, ont été ajoutées dans la version V1.11.01 du logiciel.

**Tableau 7** : Indications de charge pour l'étalonnage de batterie IMPRES 2 ou IMPRES – étalonnage activé

État	Écran du logement	Voyant lumineux
Mise sous tension du chargeur	IMPRES 2 CHARGER	Vert pendant environ une seconde 
Batterie détectée	IMPRES 2 BATTERY OU IMPRES BATTERY	Ambre fixe 

**Tableau 7 : Indications de charge pour l'étalonnage de batterie IMPRES 2 ou IMPRES – étalonnage activé (suite)**

État	Écran du logement	Voyant lumineux
Décharge de la batterie	CAL DISCHARGE xxxxx0mAh yy%Pt1	Ambre fixe 
Charge rapide	CAL RAPID CHARGE xxxxx0mAh yy%Pt1	Rouge fixe 
Charge à 90 % ou plus	CAL TRICKLE CHARGE xxxxx0mAh yy%Pt1	Vert clignotant 
Charge à 95 % ou plus	<p>ÉTALONNAGE DE LA BATTERIE RÉUSSI :</p> <p>Vert fixe </p> <p>Batterie étalonnée avec succès, mais peut approcher de la fin de son cycle de vie (la batterie est utilisable) :</p> <p>Clignote en alternance rouge/vert </p>	
	<p>L'ÉTALONNAGE DE LA BATTERIE A RÉUSSI, MAIS LA BATTERIE A ÉTÉ EXPOSÉE À UNE SURCHAUFFE CUMULATIVE (IL EST CONSEILLÉ DE LA RETIRER DU GROUPE) :</p> <p>Alternance rouge/vert</p> <p>REMARQUE : Applicable uniquement pour la batterie APX NEXT XN </p>	
Défaillance	WARNING: NOT CHARGEABLE REMOVE & REINSERT	Rouge clignotant 
<p>Veille</p> <ul style="list-style-type: none"> <li>• La batterie est en attente de charge rapide.</li> <li>• La batterie est trop chaude ou trop froide, ou sa tension est faible.</li> <li>• Le chargeur est trop chaud.</li> </ul>	<p>WARNING:</p> <p>HOT BATTERY WAITING TO CAL OU COLD BATTERY WAITING TO CAL OU VERY LOW BATTERY WAITING TO CHARGE OU HOT CHARGER WAITING TO CAL</p>	Ambre clignotant 

**Tableau 8 :** Indications de charge pour l'étalonnage de batterie IMPRES 2 ou IMPRES – étalonnage d'abord désactivé, puis activé

État	Écran du chargeur	Voyant lumineux
Mise sous tension du chargeur	IMPRES 2 CHARGER	Vert pendant environ une seconde 
Batterie détectée	IMPRES 2 BATTERY ou IMPRES BATTERY	La batterie requiert un étalonnage, mais l'étalonnage est désactivé sur le chargeur : Alternance ambre/vert pendant 4 secondes 
Demande d'étalonnage de batterie IMPRES <ul style="list-style-type: none"> <li>L'étalonnage est désactivé dans le chargeur.</li> <li>La batterie est en charge</li> </ul>	WARNING: ENABLE BATTERY CALIBRATION? <ul style="list-style-type: none"> <li>Appuyer sur OK pour activer l'étalonnage</li> <li>Ignorer pour la charge normale (message supprimé après 1 minute)</li> </ul>	Rouge fixe 
Décharge de la batterie <ul style="list-style-type: none"> <li>OK sélectionné</li> </ul>	CAL DISCHARGE xxxxx@mAh yyy%P t1	Ambre fixe 
Charge rapide	CAL RAPID CHARGE xxxxx@mAh yyy%P t1	Rouge fixe 
Charge à 90 % ou plus	CAL TRICKLE CHARGE xxxxx@mAh yyy%P t1	Vert clignotant 

**Tableau 8 :** Indications de charge pour l'étalonnage de batterie IMPRES 2 ou IMPRES – étalonnage d'abord désactivé, puis activé (suite)

État	Écran du chargeur	Voyant lumineux
Charge à 95 % ou plus	<p>CHARGE COMPLETE xxxxx@mAh yyy%P t1</p>	<p>Étalonnage de la batterie réussi : Vert fixe </p> <p>Batterie étalonnée avec succès, mais peut approcher de la fin de son cycle de vie (la batterie est utilisable) : Clignote en alternance rouge/vert </p>
	<p>REPLACE BATTERY EXPOSED OVERTEMP</p>	<p>L'étalonnage de la batterie a réussi, mais la batterie a été exposée à une surchauffe cumulative (il est conseillé de la retirer du groupe) : Alternance rouge/vert REMARQUE : Applicable uniquement pour la batterie APX NEXT XN </p>
Défaillance	<p>WARNING: NOT CHARGEABLE REMOVE&amp; REINSERT</p>	<p>Rouge clignotant </p>
<p>Veille</p> <ul style="list-style-type: none"> <li>• La batterie est en attente de charge rapide.</li> <li>• La batterie est trop chaude ou trop froide, ou sa tension est faible.</li> <li>• Le chargeur est trop chaud.</li> </ul>	<p>WARNING: HOT BATTERY WAITING TO CAL OU COLD BATTERY WAITING TO CAL OU VERY LOW BATTERY WAITING TO CHARGE OU HOT CHARGER WAITING TO CAL</p>	<p>Ambre clignotant </p>

**Tableau 9** : Indications de charge d'une batterie IMPRES 2 ou IMPRES – étalonnage requis, mais non activé

État	Écran du chargeur	Voyant lumineux
Mise sous tension du chargeur	IMPRES 2 CHARGER	Vert pendant environ une seconde 
Batterie détectée	IMPRES 2 BATTERY ou IMPRES BATTERY	La batterie requiert un étalonnage, mais l'étalonnage est désactivé sur le chargeur : Alternance ambre/vert pendant 4 secondes 
Demande d'étalonnage de batterie IMPRES <ul style="list-style-type: none"><li>L'étalonnage est désactivé dans le chargeur.</li><li>La batterie est en chargement.</li></ul>	WARNING: ENABLE BATTERY CALIBRATION?  <ul style="list-style-type: none"><li>Appuyez sur OK pour activer l'étalonnage.</li><li>Ignorez pour la charge normale (message supprimé après 1 minute).</li></ul>	Rouge fixe 
Charge rapide <ul style="list-style-type: none"><li>Dépassement du délai de la demande d'étalonnage.</li></ul>	RAPID CHARGE xxxxx@mAh yyy%P t1	Rouge fixe 
Charge à 90 % ou plus	TRICKLE CHARGE xxxxx@mAh yyy%P t1	Vert clignotant 
Charge à 95 % ou plus	CHARGE COMPLETE xxxxx@mAh yyy%P t1	Alternance ambre/vert 
Défaillance	WARNING: NOT CHARGEABLE REMOVE& REINSERT	Rouge clignotant 
Veille <ul style="list-style-type: none"><li>La batterie est en attente de charge rapide.</li><li>La batterie est trop chaude ou trop froide, ou sa tension est faible.</li><li>Le chargeur est trop chaud.</li></ul>	WARNING: HOT BATTERY WAITING TO CHARGE OU COLD BATTERY WAITING TO CHARGE OU VERY LOW BATTERY WAITING TO CHARGE OU HOT CHARGER WAITING TO CHARGE	Ambre clignotant 

**Tableau 10** : Indications de charge d'une batterie IMPRES 2 ou IMPRES complètement chargée – étalonnage requis, mais non activé

État	Écran du chargeur	Voyant lumineux
Mise sous tension du chargeur	IMPRES 2 CHARGER	Vert pendant environ une seconde 
Batterie détectée	IMPRES 2 BATTERY ou IMPRES BATTERY	La batterie doit être étalonnée, mais elle a été entièrement chargée dans les 30 dernières minutes et l'étalonnage est désactivé dans le chargeur : Alternance ambre/vert 
Défaillance	WARNING: NOT CHARGEABLE REMOVE& REINSERT	Rouge clignotant 
Veille <ul style="list-style-type: none"> <li>• La batterie est en attente de charge rapide.</li> <li>• La batterie est trop chaude ou trop froide, ou sa tension est faible.</li> <li>• Le chargeur est trop chaud.</li> </ul>	WARNING: HOT BATTERY WAITING TO CHARGE OU COLD BATTERY WAITING TO CHARGE OU VERY LOW BATTERY WAITING TO CHARGE OU HOT CHARGER WAITING TO CHARGE	Ambre clignotant 



## Autres batteries de Motorola Solutions

**Tableau 11** : Indications de charge d'autres batteries  
Motorola Solutions

État	Écran du chargeur	Voyant lumineux
Mise sous tension du chargeur	IMPRES 2 CHARGER	Vert pendant environ une seconde 
Batterie détectée	MOTOROLA SOLUTIONS BATTERY	Rouge fixe 
Charge rapide	RAPID CHARGE	Rouge fixe 
Charge à 90 % ou plus	TRICKLE CHARGE	Vert clignotant 
Charge à 95 % ou plus	CHARGE COMPLETE	Vert fixe 
Défaillance	WARNING: NOT CHARGEABLE REMOVE & REINSERT	Rouge clignotant 
Veille <ul style="list-style-type: none"> <li>• La batterie est en attente de charge rapide.</li> <li>• La batterie est trop chaude ou trop froide, ou sa tension est faible.</li> <li>• Le chargeur est trop chaud.</li> </ul>	WARNING: HOT BATTERY WAITING TO CHARGE OU COLD BATTERY WAITING TO CHARGE OU VERY LOW BATTERY WAITING TO CHARGE OU HOT CHARGER WAITING TO CHARGE	Ambre clignotant 

## Batterie non reconnue

Certaines batteries non reconnues peuvent ne pas être détectées par le chargeur. Les batteries non reconnues ne déclarent pas les paramètres de charge de façon reconnaissable par le chargeur. Si une batterie non reconnue est détectée, le chargeur indique la charge comme représenté dans le Tableau 12.

**Tableau 12 :** Indications de charge de batteries d'origine inconnue

État	Écran du chargeur	Voyant lumineux
Mise sous tension du chargeur	IMPRES 2 CHARGER	Vert pendant environ une seconde 
Batterie détectée	UNKNOWN BATTERY	Rouge fixe 
Charge rapide	RAPID CHARGE	Rouge fixe 
Charge presque complète • Capacité de la batterie inconnue	TRICKLE CHARGE	Vert clignotant 
Chargé • Capacité de la batterie inconnue	CHARGE COMPLETE	Vert fixe 
Défaillance	WARNING: HOT CHARGEABLE REMOVE & REINSERT	Rouge clignotant 
Veille • La batterie est en attente de charge rapide. • La batterie est trop chaude ou trop froide, ou sa tension est faible. • Le chargeur est trop chaud.	WARNING: HOT BATTERY WAITING TO CHARGE OU COLD BATTERY WAITING TO CHARGE OU VERY LOW BATTERY WAITING TO CHARGE OU HOT CHARGER WAITING TO CHARGE	Ambre clignotant 

## Stockage à long terme d'une batterie IMPRES 2 ou IMPRES

Les batteries IMPRES 2 et IMPRES autonomes Motorola Solutions d'origine (lithium-ion ou nickel) peuvent être préparées pour le stockage à long terme dans un emplacement de stockage convenable en utilisant le multichargeur IMPRES 2. Les autres types de batteries ne fonctionneront pas. Si la batterie IMPRES 2 dispose du mode veille, le chargeur met la batterie en veille une fois que la charge pour le stockage à long terme est achevée.

Préparez seulement les batteries IMPRES 2 ou IMPRES pour le stockage à long terme. Retirez la batterie de la radio avant de la placer dans le chargeur.

NE RANGEZ PAS une batterie autonome dans le chargeur. Lorsque la préparation pour le stockage à long terme est achevée, retirez immédiatement la batterie autonome du chargeur.

La sélection du stockage à long terme remplace l'étalonnage/remise en état. Les batteries au lithium préparées pour le stockage à long terme peuvent ne pas respecter les réglementations pour l'expédition par fret aérien.

**Tableau 13 :** Indications de stockage à long terme d'une batterie IMPRES 2 ou IMPRES – la batterie doit être étalonnée

État	Écran du chargeur	Voyant lumineux
Mise sous tension du chargeur	IMPRES 2 CHARGER	Vert pendant environ une seconde 
Batterie détectée	IMPRES 2 BATTERY ou IMPRES BATTERY	La batterie doit être étalonnée : Alternance ambre/vert pendant 4 secondes 
Décharge de la batterie	STORAGE DISCHARGE xxxx% Rated Cap	Ambre fixe 
Charge rapide	STORAGE CHARGE xxx% Rated Cap	Rouge fixe 
Stockage à long terme achevé	LONGTERM STORAGE xxx% Rated Cap	Alternance ambre/vert 

**Tableau 13** : Indications de stockage à long terme d'une batterie IMPRES 2 ou IMPRES – la batterie doit être étalonnée (suite)

État	Écran du chargeur	Voyant lumineux
<p>Défaillance</p> <ul style="list-style-type: none"> <li>• Il peut y avoir un problème d'interface entre les bornes de la batterie et du chargeur.</li> <li>• La batterie n'est pas une batterie IMPRES 2 ou IMPRES.</li> <li>• Une erreur inconnue empêche la batterie de se décharger.</li> <li>• La charge a été achevée avant que l'objectif de stockage à long terme soit atteint.</li> <li>• Le logement du chargeur est d'un type spécial.</li> </ul>	<p>WARNING:            NOT CHARGEABLE            REMOVE&amp; REINSERT            OU            WRONG BATT TYPE            CANNOT LT STORE            OU            CANNOT DISCHARGE            FOR LT STORAGE            OU            STORE INCOMPLETE            Low Capacity:yy%            OU            RADIO POCKET            CANNOT LT STORE            OU            CHARGING POCKET            CANNOT LT STORE</p>	<p>Rouge clignotant</p> 
<p>Veille</p> <ul style="list-style-type: none"> <li>• La batterie est en attente de charge rapide.</li> <li>• La batterie est trop chaude ou trop froide, ou sa tension est faible.</li> <li>• Le chargeur est trop chaud.</li> </ul>	<p>WARNING:            HOT BATTERY            WAITING TO CHRGE            OU            COLD BATTERY            WAITING TO CHRGE            OU            VERY LOW BATTERY            WAITING TO CHRGE            OU            HOT CHARGER            WAITING TO CHRGE</p>	<p>Ambre clignotant</p> 

**Remarque :**

- Les messages suivants ont été ajoutés dans la version V1.05 du logiciel :
  - Cannot Discharge, for LT Storage
  - Store Incomplete, Low Capacity:yy%
  - Hot Charger, Waiting to Chrge
- Les messages suivants ont été ajoutés dans la version V1.11.01 du logiciel :
  - Wrong Batt Type, Cannot LT Store
  - Radio Pocket, Cannot LT Store
  - Charging Pocket, Cannot LT Store

**Tableau 14** : Indications de stockage à long terme de la batterie IMPRES 2 ou IMPRES – batterie étalonnée, doit être chargée jusqu'à la capacité appropriée pour la sélection

État	Écran du chargeur	Voyant lumineux
Mise sous tension du chargeur	IMPRES 2 CHARGER	Vert pendant environ une seconde 
Batterie détectée	IMPRES 2 BATTERY ou IMPRES BATTERY	Rouge fixe 
Charge rapide	STORAGE CHARGE xxx% Rated Cap	Rouge fixe 
Stockage à long terme achevé	LONGTERM STORAGE xxx% Rated Cap	Vert fixe 
<p>Défaillance</p> <ul style="list-style-type: none"> <li>• Il peut y avoir un problème d'interface entre les bornes de la batterie et du chargeur.</li> <li>• La batterie n'est pas une batterie IMPRES 2 ou IMPRES.</li> <li>• Une erreur inconnue empêche la batterie de se décharger.</li> <li>• La charge a été achevée avant que l'objectif de stockage à long terme soit atteint.</li> <li>• Le logement du chargeur est d'un type spécial.</li> </ul>	<p>WARNING: NOT CHARGEABLE REMOVE&amp; REINSERT OU WRONG BATT TYPE CANNOT LT STORE OU CANNOT DISCHARGE FOR LT STORAGE OU STORE INCOMPLETE Low Capacity:yy% OU RADIO POCKET CANNOT LT STORE OU CHARGING POCKET CANNOT LT STORE</p>	<p>Rouge clignotant </p>
<p>Veille</p> <ul style="list-style-type: none"> <li>• La batterie est en attente de charge rapide.</li> <li>• La batterie est trop chaude ou trop froide, ou sa tension est faible.</li> <li>• Le chargeur est trop chaud.</li> </ul>	<p>WARNING: HOT BATTERY WAITING TO CHARGE OU COLD BATTERY WAITING TO CHARGE OU VERY LOW BATTERY WAITING TO CHARGE OU HOT CHARGER WAITING TO CHARGE</p>	<p>Ambre clignotant </p>

**Tableau 15 :** Indications de stockage à long terme de la batterie IMPRES 2 ou IMPRES – batterie étalonnée, doit être déchargée jusqu'à la capacité appropriée pour la sélection

État	Écran du chargeur	Voyant lumineux
Mise sous tension du chargeur	IMPRES 2 CHARGER	Vert pendant environ une seconde 
Batterie détectée	IMPRES 2 BATTERY ou IMPRES BATTERY	Ambre fixe 
Décharge de la batterie	STORAGE DISCHARGE xxx% Rated Cap	Ambre fixe 
Stockage à long terme achevé	LONGTERM STORAGE xxx% Rated Cap	Vert fixe 
<p>Défaillance</p> <ul style="list-style-type: none"> <li>• Il peut y avoir un problème d'interface entre les bornes de la batterie et du chargeur.</li> <li>• La batterie n'est pas une batterie IMPRES 2 ou IMPRES.</li> <li>• Une erreur inconnue empêche la batterie de se décharger.</li> <li>• La charge a été achevée avant que l'objectif de stockage à long terme soit atteint.</li> <li>• Le logement du chargeur est d'un type spécial.</li> </ul>	<p>WARNING: NOT CHARGEABLE REMOVE &amp; REINSERT OU WRONG BATT TYPE CANNOT LT STORE OU CANNOT DISCHARGE FOR LT STORAGE OU STORE INCOMPLETE Low Capacity:yy% OU RADIO POCKET CANNOT LT STORE OU CHARGING POCKET CANNOT LT STORE</p>	<p>Rouge clignotant</p> 
<p>Veille</p> <ul style="list-style-type: none"> <li>• La batterie est en attente de charge rapide.</li> <li>• La batterie est trop chaude ou trop froide, ou sa tension est faible.</li> <li>• Le chargeur est trop chaud.</li> </ul>	<p>WARNING: HOT BATTERY WAITING TO CHARGE OU COLD BATTERY WAITING TO CHARGE OU VERY LOW BATTERY WAITING TO CHARGE OU HOT CHARGER WAITING TO CHARGE</p>	<p>Ambre clignotant</p> 

## Préparation de la batterie au lithium-ion pour l'expédition

Les batteries IMPRES 2 et IMPRES ou d'autres batteries au lithium-ion Motorola Solutions d'origine peuvent être préparées pour l'expédition par fret aérien en utilisant un multichargeur IMPRES 2. Les autres types de batteries ne fonctionneront pas. Si la batterie IMPRES 2 au lithium-ion dispose du mode veille, le chargeur met la batterie en veille une fois que la charge pour l'expédition d'une batterie au lithium est achevée.

Préparez uniquement des batteries autonomes au lithium-ion Motorola Solutions pour l'expédition. Retirez la batterie de la radio avant de la placer dans le chargeur.

NE RANGEZ PAS une batterie autonome dans le chargeur. Lorsque la préparation de la batterie au lithium pour l'expédition est achevée, retirez immédiatement la batterie autonome du chargeur.

La sélection de l'expédition de batterie au lithium a préséance sur l'étalonnage/remise en état.

### Batterie IMPRES 2 ou IMPRES

**Tableau 16** : Indications d'état de préparation d'une batterie au lithium-ion pour l'expédition – la batterie IMPRES 2 ou IMPRES doit être étalonnée

État	Écran du chargeur	Voyant lumineux
Mise sous tension du chargeur	IMPRES 2 CHARGER	Vert pendant environ une seconde 
Batterie détectée	IMPRES 2 BATTERY ou IMPRES BATTERY	La batterie doit être étalonnée : Alternance ambre/vert pendant 4 secondes 
Décharge de la batterie	SHIP LI DISCHRG xxx% Rated Cap	Ambre fixe 
Charge rapide	SHIP LI CHARGE xxx% Rated Cap	Rouge fixe 
Expédition lithium achevée	LI READY TO SHIP xxx% Rated Cap	Alternance ambre/vert 

**Tableau 16** : Indications d'état de préparation d'une batterie au lithium-ion pour l'expédition – la batterie IMPRES 2 ou IMPRES doit être étalonnée (suite)

État	Écran du chargeur	Voyant lumineux
<p>Défaillance</p> <ul style="list-style-type: none"> <li>• Il peut y avoir un problème d'interface entre les bornes de la batterie et du chargeur.</li> <li>• Batterie non reconnue ou au nickel.</li> <li>• Une erreur inconnue empêche la batterie de se décharger.</li> <li>• La charge est complétée avant l'atteinte de l'objectif pour l'expédition de la batterie au lithium.</li> <li>• Le logement du chargeur est d'un type spécial.</li> </ul>	<p>WARNING: NOT CHARGEABLE REMOVE&amp; REINSERT OU WRONG BATT TYPE CANNOT SHIP LI OU CANNOT DISCHARGE FOR LI SHIPMENT OU SHIP INCOMPLETE Low Capacity:yy% OU RADIO POCKET CANNOT SHIP LI OU CHARGING POCKET CANNOT SHIP LI</p>	<p>Rouge clignotant</p> 
<p>Veille</p> <ul style="list-style-type: none"> <li>• La batterie est en attente de charge rapide.</li> <li>• La batterie est trop chaude ou trop froide, ou sa tension est faible.</li> <li>• Le chargeur est trop chaud.</li> </ul>	<p>WARNING: HOT BATTERY WAITING TO CHARGE OU COLD BATTERY WAITING TO CHARGE OU VERY LOW BATTERY WAITING TO CHARGE OU HOT CHARGER WAITING TO CHARGE</p>	<p>Ambre clignotant</p> 

**Remarque :**

- Les messages suivants ont été ajoutés dans la version V1.05 du logiciel :
  - Ship LI Discharge, xxx% Rated Capacity
  - Ship LI Charge, xxx% Rated Capacity
  - LI Ready to Ship, xx% Rated Capacity
  - Cannot Discharge, for LI Shipment
  - Ship Incomplete, Low Capacity:yy%
- Les messages suivants ont été ajoutés dans la version V1.11.01 du logiciel :
  - Wrong Batt Type, Cannot Ship LI
  - Radio Pocket, Cannot Ship LI
  - Charging Pocket, Cannot Ship LI



**Tableau 17** : Indications d'état de préparation d'une batterie au lithium-ion pour l'expédition – la batterie IMPRES 2 ou IMPRES doit être chargée

État	Écran du chargeur	Voyant lumineux
Mise sous tension du chargeur	IMPRES 2 CHARGER	Vert pendant environ une seconde 
Batterie détectée	IMPRES 2 BATTERY ou IMPRES BATTERY	Rouge fixe 
Charge rapide	SHIP LI CHARGE xxx% Rated Cap	Rouge fixe 
Expédition lithium achevée	LI READY TO SHIP xxx% Rated Cap	Vert fixe 
<p>Défaillance</p> <ul style="list-style-type: none"> <li>• Il peut y avoir un problème d'interface entre les bornes de la batterie et du chargeur.</li> <li>• Batterie non reconnue ou au nickel</li> <li>• Une erreur inconnue empêche la batterie de se décharger.</li> <li>• La charge est complétée avant l'atteinte de l'objectif pour l'expédition de la batterie au lithium.</li> <li>• Le logement du chargeur est d'un type spécial.</li> </ul>	<p>WARNING:</p> <p>HOT CHARGEABLE REMOVE&amp; REINSERT OU</p> <p>WRONG BATT TYPE CANNOT SHIP LI OU</p> <p>CANNOT DISCHARGE FOR LI SHIPMENT OU</p> <p>SHIP INCOMPLETE Low Capacity:yy%</p> <p>OU</p> <p>RADIO POCKET CANNOT SHIP LI OU</p> <p>CHARGING POCKET CANNOT SHIP LI</p>	Rouge clignotant 
<p>Veille</p> <ul style="list-style-type: none"> <li>• La batterie est en attente de charge rapide.</li> <li>• La batterie est trop chaude ou trop froide, ou sa tension est faible.</li> <li>• Le chargeur est trop chaud.</li> </ul>	<p>WARNING:</p> <p>HOT BATTERY WAITING TO CHARGE OU</p> <p>COLD BATTERY WAITING TO CHARGE OU</p> <p>VERY LOW BATTERY WAITING TO CHARGE OU</p> <p>HOT CHARGER WAITING TO CHARGE</p>	Ambre clignotant 

**Tableau 18 :** Indications d'état de préparation d'une batterie au lithium-ion pour l'expédition – la batterie IMPRES 2 ou IMPRES est étalonnée, mais doit être déchargée

État	Écran du chargeur	Voyant lumineux
Mise sous tension du chargeur	IMPRES 2 CHARGER	Vert pendant environ une seconde 
Batterie détectée	IMPRES 2 BATTERY ou IMPRES BATTERY	Ambre fixe 
Décharge de la batterie	SHIP LI DISCHARGE xxx% Rated Cap	Ambre fixe 
Expédition lithium achevée	LI READY TO SHIP xxx% Rated Cap	Vert fixe 
Défaillance <ul style="list-style-type: none"> <li>Il peut y avoir un problème d'interface entre les bornes de la batterie et du chargeur.</li> <li>Batterie non reconnue ou au nickel</li> <li>Une erreur inconnue empêche la batterie de se décharger.</li> <li>La charge est complétée avant l'atteinte de l'objectif pour l'expédition de la batterie au lithium.</li> <li>Le logement du chargeur est d'un type spécial.</li> </ul>	WARNING: HOT CHARGEABLE REMOVE& REINSERT OU WRONG BATT TYPE CANNOT SHIP LI OU CANNOT DISCHARGE FOR LI SHIPMENT OU SHIP INCOMPLETE Low Capacity:yy% OU RADIO POCKET CANNOT SHIP LI OU CHARGING POCKET CANNOT SHIP LI	Rouge clignotant 
Veille <ul style="list-style-type: none"> <li>La batterie est en attente de charge rapide.</li> <li>La batterie est trop chaude ou trop froide, ou sa tension est faible.</li> <li>Le chargeur est trop chaud.</li> </ul>	WARNING: HOT BATTERY WAITING TO CHARGE OU COLD BATTERY WAITING TO CHARGE OU VERY LOW BATTERY WAITING TO CHARGE OU HOT CHARGER WAITING TO CHARGE	Ambre clignotant 

## Autres batteries de Motorola Solutions

**Tableau 19 :** Indications d'état d'une batterie au lithium-ion préparée pour l'expédition – autre batterie Motorola Solutions

État	Écran du chargeur	Voyant lumineux
Mise sous tension du chargeur	IMPRES 2 CHARGER	Vert pendant environ une seconde 
Batterie détectée	MOTOROLA SOLUTIONS BATTERY	Ambre fixe 
Décharge de la batterie	SHIP LI DISCHARGE xxx% Rated Cap	Ambre fixe 
Charge rapide	SHIP LI CHARGE xxx% Rated Cap	Rouge fixe 
Expédition lithium achevée	LI READY TO SHIP xxx% Rated Cap	Vert fixe 
<b>Défaillance</b> <ul style="list-style-type: none"> <li>Il peut y avoir un problème d'interface entre les bornes de la batterie et du chargeur.</li> <li>Batterie non reconnue ou au nickel</li> <li>Une erreur inconnue empêche la batterie de se décharger.</li> <li>La charge est complétée avant l'atteinte de l'objectif pour l'expédition de la batterie au lithium.</li> <li>Le logement du chargeur est d'un type spécial.</li> </ul>	WARNING: NOT CHARGEABLE REMOVE& REINSERT OU WRONG BATT TYPE CANNOT SHIP LI OU CANNOT DISCHARGE FOR LI SHIPMENT OU SHIP INCOMPLETE Low Capacity:yy% OU RADIO POCKET CANNOT SHIP LI OU CHARGING POCKET CANNOT SHIP LI	Rouge clignotant 
<b>Veille</b> <ul style="list-style-type: none"> <li>La batterie est en attente de charge rapide.</li> <li>La batterie est trop chaude ou trop froide, ou sa tension est faible.</li> <li>Le chargeur est trop chaud.</li> </ul>	WARNING: HOT BATTERY WAITING TO CHARGE OU COLD BATTERY WAITING TO CHARGE OU VERY LOW BATTERY WAITING TO CHARGE OU HOT CHARGER WAITING TO CHARGE	Ambre clignotant 

## Menu de configuration du chargeur



Vider tous les logements avant de passer à la configuration du chargeur.

Le clavier du chargeur est situé sous l'écran du logement n° 1.

Pour accéder au menu de configuration du chargeur, appuyez simultanément sur les touches flèche gauche et flèche droite et tenez-les enfoncées durant un délai plus long que le temps de saisie sélectionné (3 secondes, par défaut).

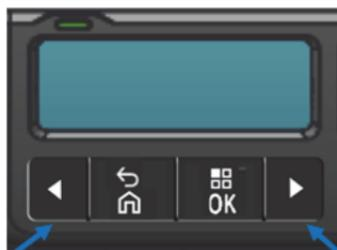

Flèche vers la gauche

Flèche vers la droite

**Figure 4 :** Touches de l'écran Menu pour l'accès au mode de configuration

### Menu principal

Au moment d'accéder à la configuration du chargeur, le message suivant s'affiche :

```
Press OK to entr  
SETUP MENU
```

Appuyer sur OK affiche le menu de configuration du chargeur disponible.

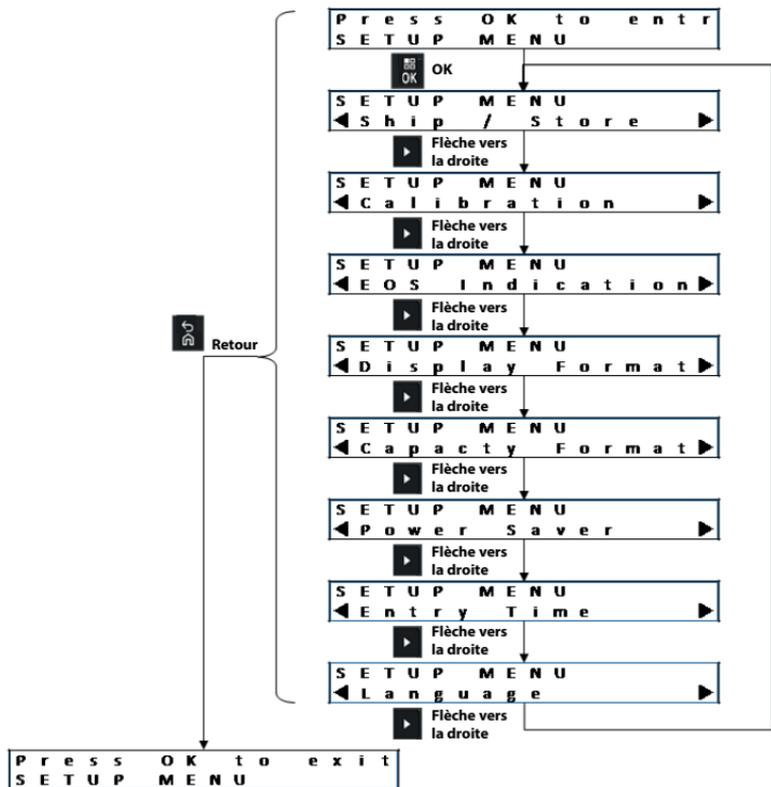

**Figure 5 :** Menu de configuration du chargeur

## Sélection de menu de configuration du chargeur

Dans chaque sélection de menu de configuration :

- Pour parcourir les sélections du menu, appuyez sur la flèche vers la droite.
- Pour parcourir les sélections du menu dans l'ordre inverse, appuyez sur la flèche vers la gauche.
- Pour entrer dans le menu sélectionné ou sélectionner l'option désirée, appuyez sur OK.

**Remarque :** Le crochet indique l'option actuellement sélectionnée. À partir de la version V1.11.01 du logiciel, il est possible d'afficher à l'écran du logement n° 1 les données relatives au logement subséquent en appuyant sur OK.



## Expédition lithium

L'option Expédition lithium règle l'état de charge d'une batterie au lithium-ion Motorola Solutions à la valeur basse autorisée pour l'expédition en vrac : environ 25 % de la capacité nominale.

Certaines batteries Motorola Solutions peuvent être complètement déchargées avant d'être rechargées jusqu'au seuil autorisé pour l'option Expédition lithium. Cela s'applique notamment pour les batteries IMPRES 2 ou IMPRES qui n'ont jamais été étalonnées ou doivent être étalonnées de nouveau, et pour les batteries Motorola Solutions d'origine autres qu'IMPRES 2 ou IMPRES.

L'option Expédition lithium s'applique uniquement pour les batteries au lithium-ion Motorola Solutions d'origine (IMPRES 2, IMPRES ou d'autres batteries au lithium-ion Motorola Solutions). Les autres batteries (par exemple, batteries non reconnues, batteries au nickel Motorola Solutions ou batteries à coque) ne fonctionneront pas.

## Stockage à long terme

L'option Stockage à long terme règle l'état de charge d'une batterie IMPRES 2 ou IMPRES à la valeur d'état de charge appropriée pour le stockage de longue durée. En règle générale, l'état de charge approprié pour le stockage se situe bien en dessous de la charge complète. La sélection `xx%` est une valeur programmée dans la batterie IMPRES 2 ou IMPRES, ou elle est réglée par défaut à 50 % de la capacité nominale. Le stockage à long terme à 75 % de la capacité nominale est disponible pour les scénarios nécessitant que la batterie soit stockée à une valeur d'état de charge plus élevée pour minimiser le temps de charge complète et accélérer la mise en service de la batterie ou la stocker à long terme.

Certaines batteries IMPRES 2 ou IMPRES peuvent être entièrement déchargées avant d'être rechargées pour la sélection du stockage à long terme. Cela s'applique notamment pour les batteries IMPRES 2 ou IMPRES qui n'ont jamais été étalonnées ou doivent être étalonnées de nouveau.

Le stockage à long terme s'applique uniquement pour les batteries IMPRES 2 ou IMPRES. Les autres batteries (par exemple, batteries non reconnues, batteries Motorola Solutions autres qu'IMPRES ou batteries à coque) ne fonctionneront pas.

## Batteries IMPRES 2 dotées du mode veille

Certaines batteries IMPRES 2 sont dotées d'un mode veille. Le mode veille est utilisé pour prolonger la période s'écoulant avant la prochaine charge de la batterie. Lorsque la charge pour l'option Expédition lithium ou Stockage à long terme est achevée, le chargeur met les batteries chargées en veille.

Lors de l'insertion d'une batterie IMPRES 2 mise en veille dans tout chargeur, cette batterie est réactivée. Si la batterie a été préparée pour l'option Expédition lithium et que vous la placez ensuite dans un chargeur configuré pour exécuter l'opération Expédition lithium, la batterie sera remise en veille. Si la batterie a été préparée pour l'option Stockage à long terme et que vous la placez ensuite dans un chargeur configuré pour exécuter l'opération Stockage à long terme, la batterie sera remise en veille.

## Menu d'étalonnage

Les sélections de la configuration de l'étalonnage permettent d'activer ou désactiver la phase de déchargement de l'étalonnage/remise en état. La phase de déchargement précède la charge pleine requise pour un étalonnage/remise en état réussi. Cette fonction est utile lorsque le chargeur est utilisé sur un site où il est nécessaire que la batterie soit chargée et prête pour l'utilisation le plus rapidement possible. Dans ces situations, attendre la décharge de la batterie peut être contraignant.

Lors de l'insertion dans le chargeur d'une batterie IMPRES 2 ou IMPRES nécessitant un étalonnage et déjà déchargée, le chargeur effectuera la charge de la batterie en plus de l'étalonner.

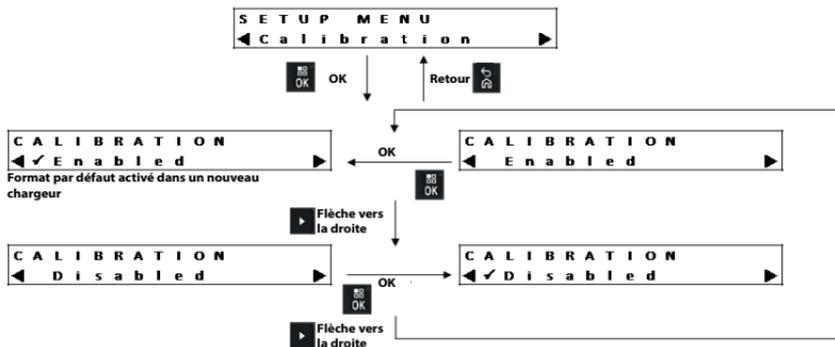

Figure 7 : Menu d'étalonnage



## Menu du voyant d'indication de fin du cycle de vie

Même si la batterie IMPRES ou IMPRES 2 approche de la fin de son cycle de vie, sa capacité peut être suffisante pour convenir à une utilisation moins exigeante. Par conséquent, il peut être préférable de désactiver l'indicateur DEL de fin de vie utile (**alternance rouge/vert**).

Pour la batterie APX NEXT XN, la désactivation de cette indication désactive également l'indication de batterie exposée à une surchauffe cumulative.

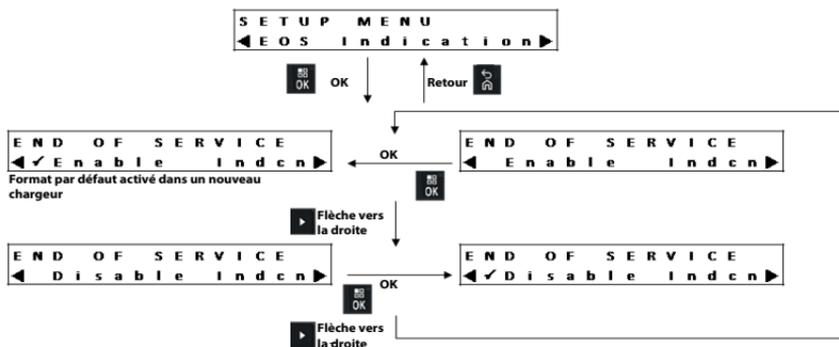

Figure 8 : Menu du voyant d'indication de fin du cycle de vie

# Menu du format d'affichage

Il existe quatre options de format d'affichage :

- Orientation normale (chargeur sur un bureau).
- Orientation inversée (chargeur accroché au mur).
- Messages d'avertissement seulement. Les autres messages ne sont pas affichés. Cela s'applique aux orientations normale et inversée. Les messages d'avertissement sont présentés dans les tableaux suivants : Tableau 6 à Tableau 12.
- L'affichage est désactivé pendant le fonctionnement normal. L'affichage est toujours activé en mode de configuration et en mode analyseur.

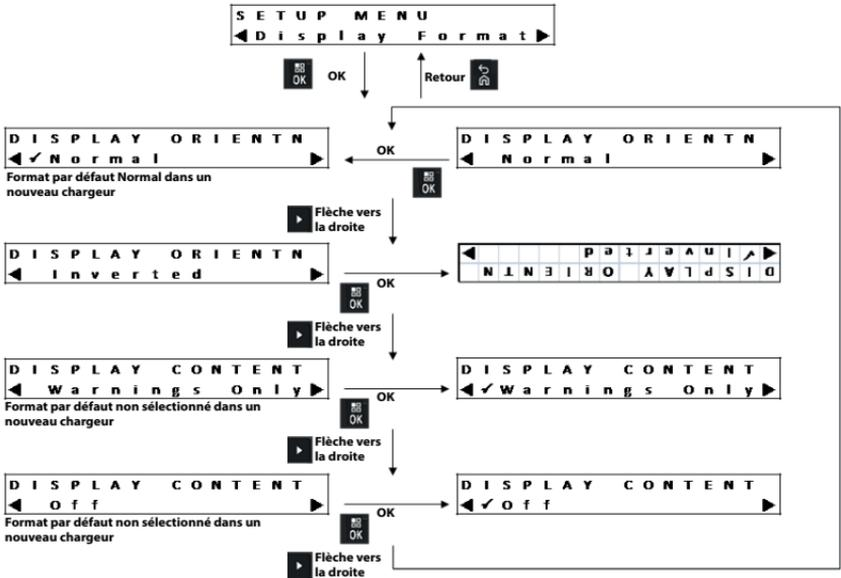

Figure 9 : Menu du format d'affichage



**Tableau 20 : Options d'affichage de la capacité de la batterie**

Représentation	Description
xxx0mAh	Présente la charge (état de charge) en milliampères-heure.
yyy%	Présente la capacité de charge par rapport à la capacité potentielle ou à la capacité nominale, en pourcentage. Lorsque la capacité de charge se rapporte à la capacité potentielle, la valeur maximum est 100 %. Lorsque la capacité de charge se rapporte à la capacité nominale, la valeur maximum peut dépasser 100 %, particulièrement dans le cas d'une batterie neuve.
%BAR	L'équivalent de yyy% représenté dans une barre de huit segments.

## Menu du mode veille

Pour répondre à certaines limites de puissance faible en mode veille, le mode de veille permet au chargeur de désactiver tous les logements à l'exception du logement n° 1 si ces logements demeurent inactifs pendant une certaine période. Exemples d'activité :

- Charge de radio ou de batterie.
- Étalonnage/remise en état de la batterie.
- Préparation d'une batterie au lithium-ion Motorola Solutions d'origine pour l'expédition.
- Préparation d'une batterie IMPRES 2 ou IMPRES pour le stockage à long terme.
- Mode de configuration ou mode analyseur du chargeur.
- Reprogrammation du chargeur.
- Communique avec le système Battery Fleet Management IMPRES.
- Toute indication clignotante du voyant.

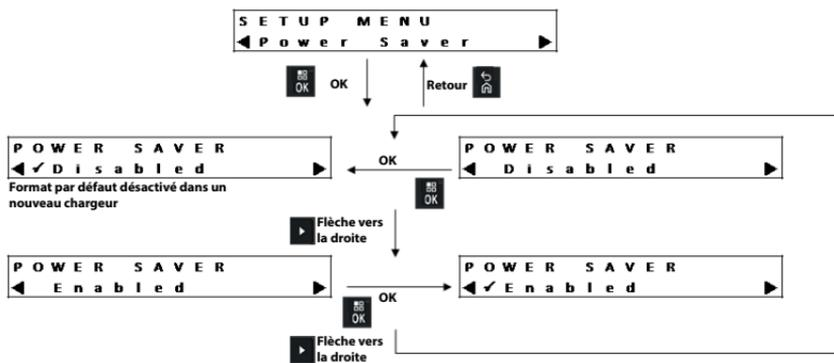

**Figure 11 : Menu du mode veille**

Le logement n° 1 reste allumé, mais peut entrer en veille. Pour activer les autres logements, appuyez sur une touche du clavier. Ces logements réagiront à l'insertion ou au retrait d'une radio ou d'une batterie uniquement une fois qu'ils auront été allumés.

## Menu Temps de saisie

Le temps de saisie correspond au délai durant lequel vous devez tenir une touche enfoncée pour activer le mode de configuration du chargeur ou le mode analyseur du chargeur.

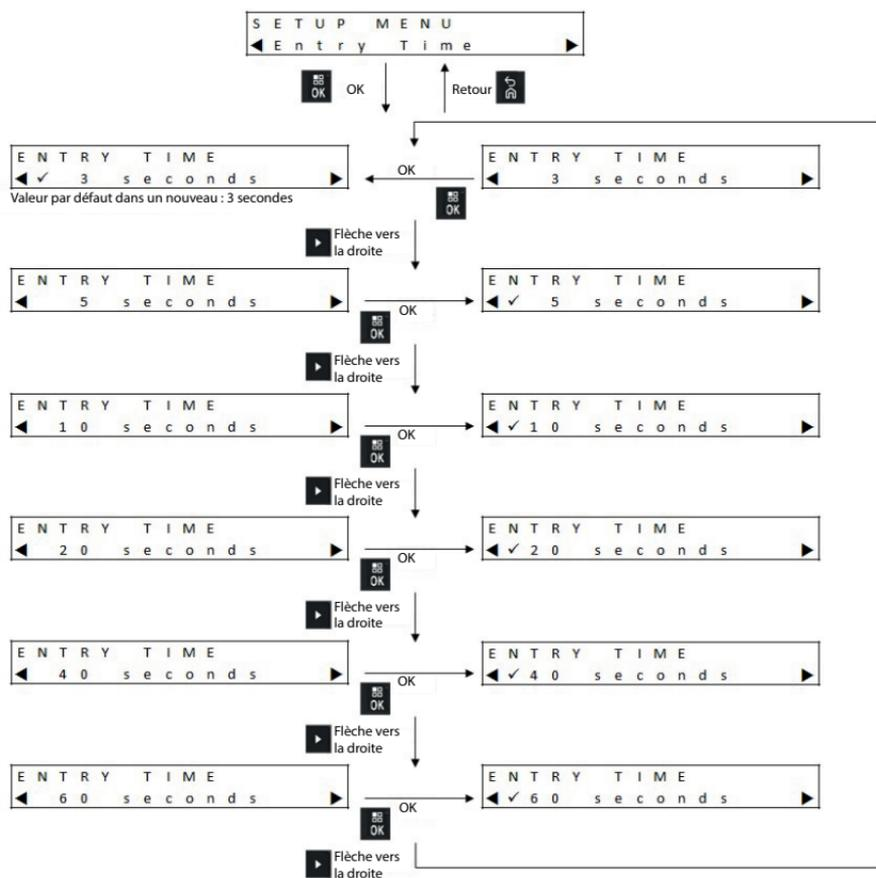

Figure 12 : Menu Temps de saisie

## Menu de langue

Actuellement, l'affichage du chargeur ne prend en charge que la langue suivante : anglais d'Amérique du Nord.

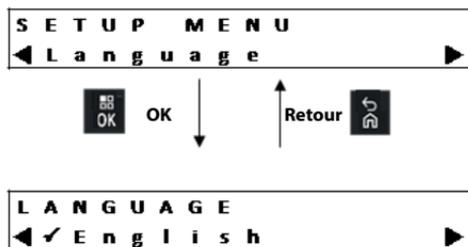

Figure 13 : Menu de langue

## Mode analyseur

Le clavier du chargeur est situé sous l'écran du logement n° 1.

Pour accéder au mode analyseur, appuyez et maintenez la touche OK enfoncée durant un délai plus long que le temps de saisie sélectionné (3 secondes, par défaut).



Figure 14 : Touches de l'écran Menu pour l'accès au mode analyseur

Au moment d'accéder au mode analyseur, le message suivant s'affiche :

```
Press OK to entr
ANALYZER MODE
```

Appuyez sur OK pour afficher l'information de batterie disponible.

## Mode analyseur, version V1.0

Dans la version V1.0 du logiciel, le mode analyseur est limité au logement n° 1. Les données de l'analyseur au sujet du logement n° 1 et de son contenu s'affichent à l'écran du logement n° 1. Si aucune touche du clavier n'est touchée pendant 10 minutes, le chargeur quitte le mode analyseur et revient à l'affichage de message normal.

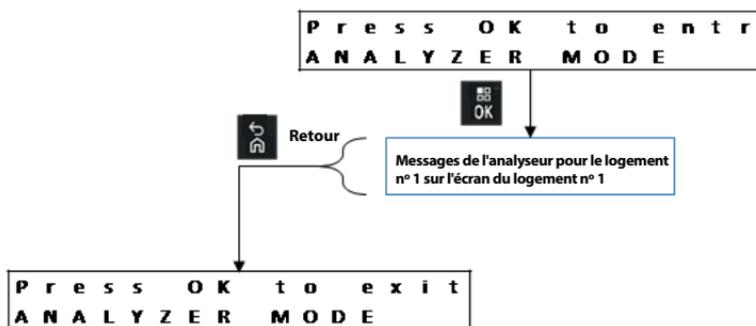

Figure 15 : Menu du mode analyseur, version V1.0

## Mode analyseur, version V1.05

Le mode analyseur a été amélioré dans la version V1.05 du logiciel. Pour les chargeurs dotés d'un écran par logement, les données de l'analyseur s'affichent à l'écran adjacent au logement visé. Lorsque vous faites défiler les données de l'analyseur pour le logement n° 1, les données de l'analyseur relatives aux autres logements s'affichent sur les écrans adjacents aux logements visés.

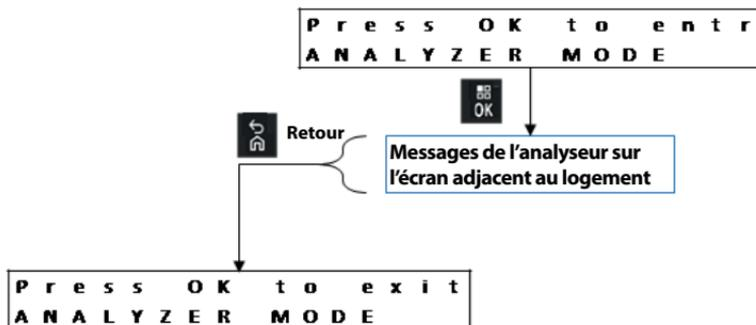

Figure 16 : Menu du mode analyseur, version V1.05

## Mode analyseur, version V1.11.01

Le mode analyseur a été amélioré de nouveau dans la version V1.11.01 du logiciel. Pour les chargeurs dont seul le logement n° 1 est doté d'un écran, il est possible d'afficher les données relatives à un autre logement du chargeur à l'écran Menu. Les améliorations de la version V1.05 sont maintenues.

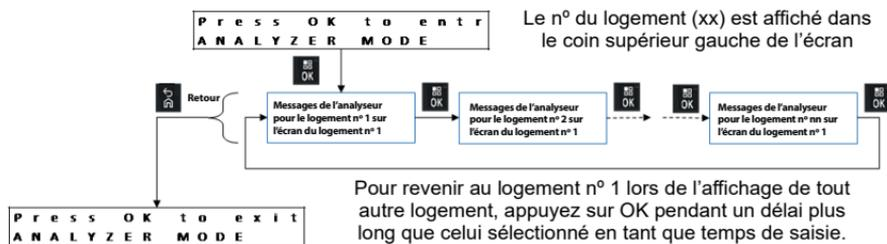

Figure 17 : Menu du mode analyseur, version V1.11.01

## Échange de batteries dans un logement

Après le retrait d'une batterie d'un logement donné, suivi de sa réinsertion ou de l'insertion d'une autre batterie dans ce même logement, le paramètre affiché pour la seconde batterie sera le même que pour la batterie initiale.

Par exemple, le paramètre `Battery IMPRES Cycles` s'affiche pour une batterie IMPRES 2 ou IMPRES donnée. Cette batterie est retirée du logement. Une batterie IMPRES 2 ou IMPRES différente est insérée dans le même logement. Le paramètre `Battery IMPRES Cycles` s'affichera en premier pour cette deuxième batterie.

Cependant, il est possible que le paramètre affiché pour la première batterie ne soit pas disponible pour la deuxième batterie. Dans ce cas, le message d'identification de la deuxième batterie s'affichera.



# Batterie IMPRES 2

## Écran adjacent au logement

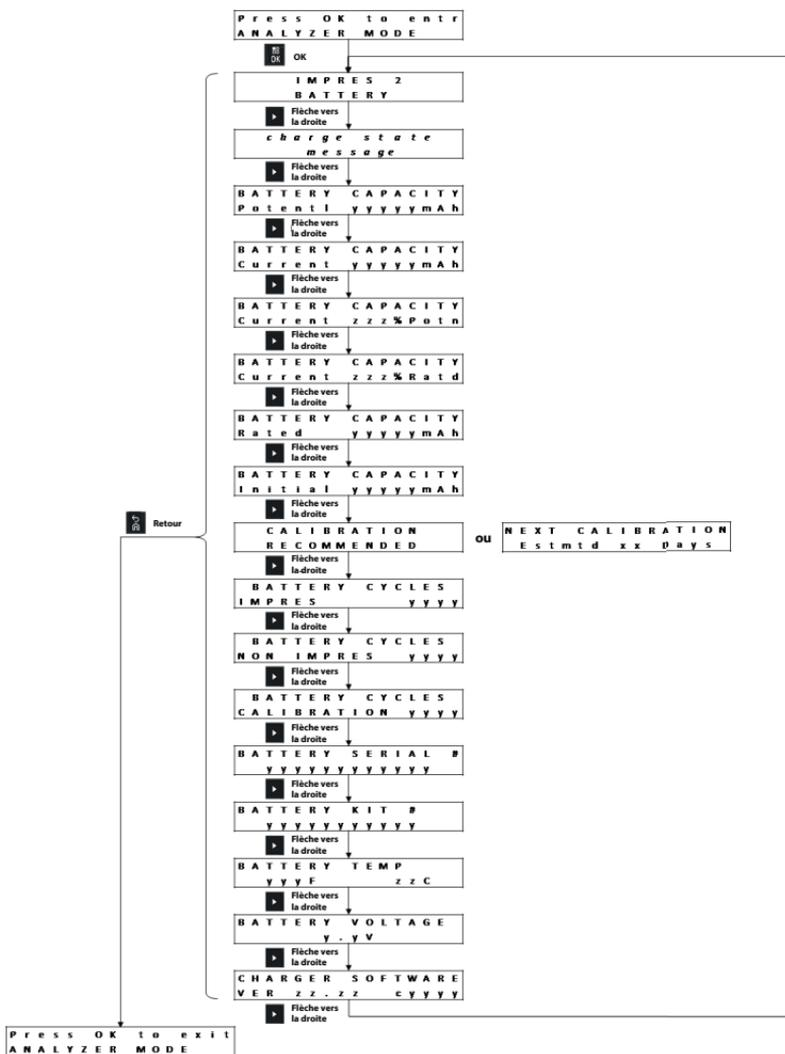

Figure 18 : Menu du mode analyseur de batterie IMPRES 2 à l'écran adjacent au logement

# Le logement n° 1 affiche un autre logement

Le n° du logement (xx) est affiché dans le coin supérieur gauche de l'écran

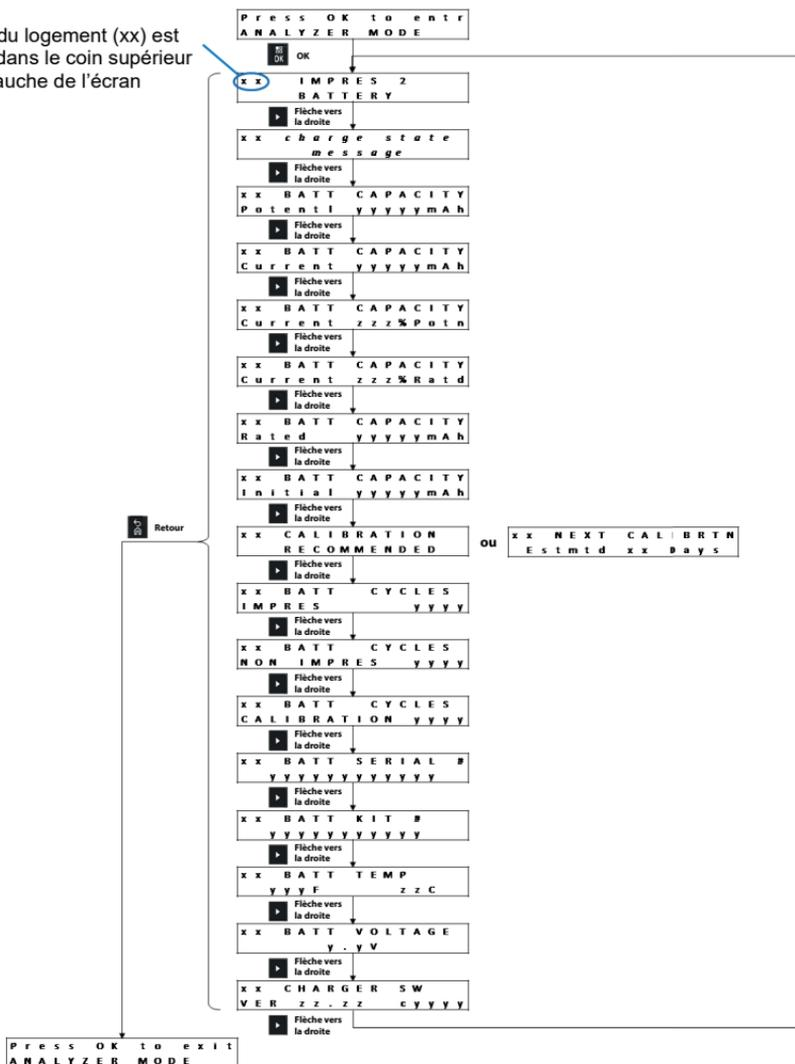

Figure 19 : Menu du mode analyseur de batterie IMPRES 2 pour un autre logement (autre que le logement n° 1)

# Batterie IMPRES

## Écran adjacent au logement

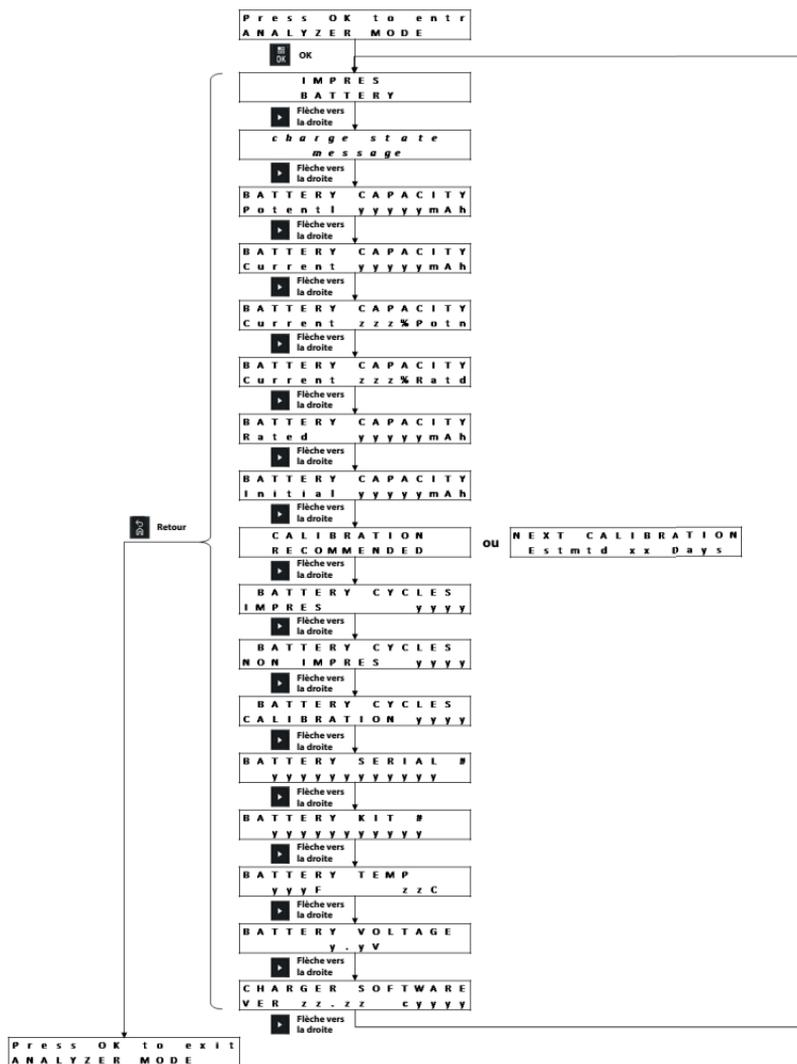

Figure 20 : Menu du mode analyseur de batterie IMPRES à l'écran adjacent au logement

# Le logement n° 1 affiche un autre logement

Le n° du logement (xx) est affiché dans le coin supérieur gauche de l'écran

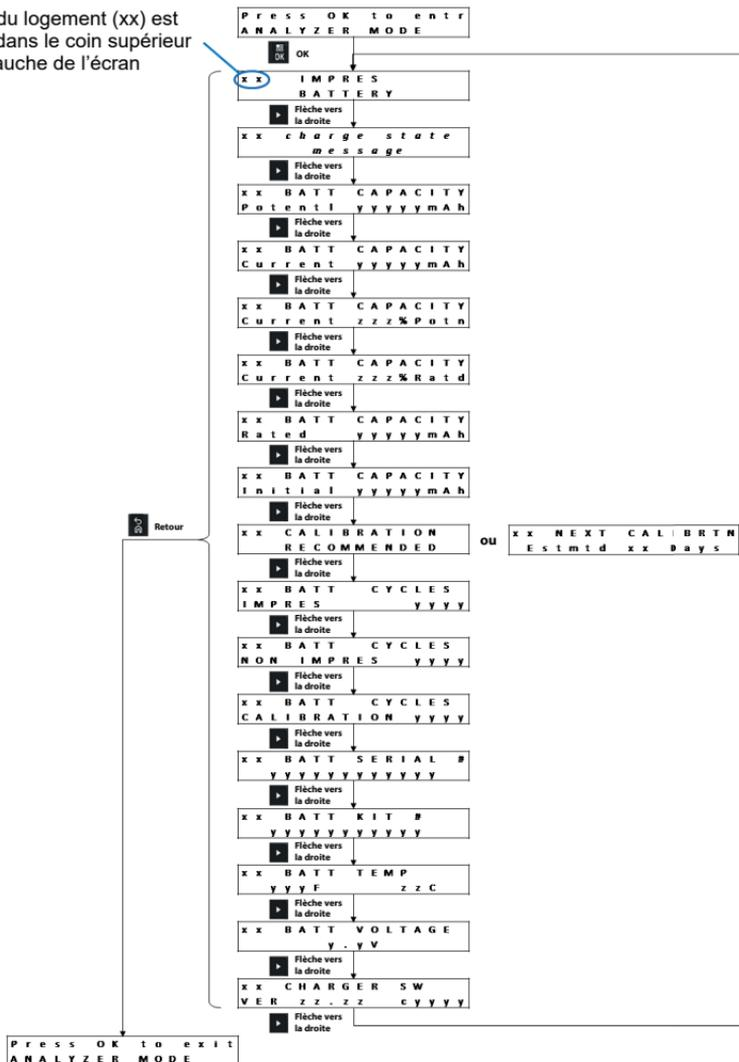

Figure 21 : Menu du mode analyseur de batterie IMPRES pour un autre logement (autre que le logement n° 1)

## Autres batteries de Motorola Solutions

### Écran adjacent au logement

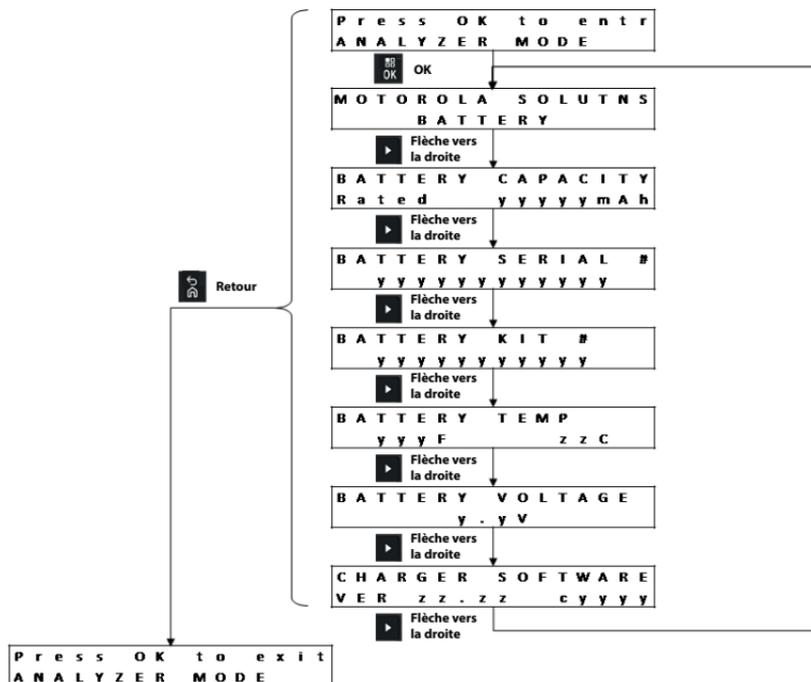
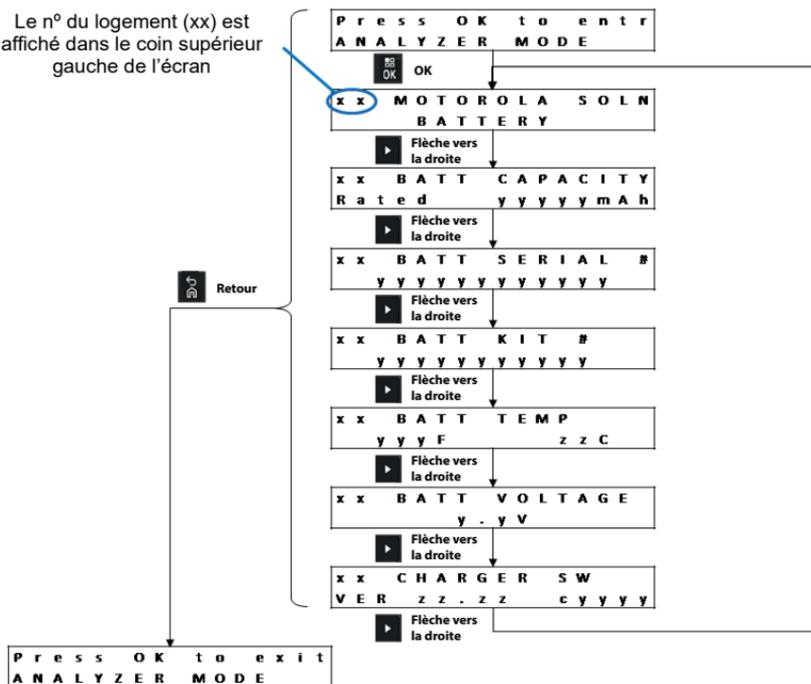

Figure 22 : Menu du mode analyseur d'autres batteries Motorola Solutions à l'écran adjacent au logement

## Le logement n° 1 affiche un autre logement

Le n° du logement (xx) est affiché dans le coin supérieur gauche de l'écran



**Figure 23** : Menu du mode analyseur d'autres batteries de Motorola Solutions pour un autre logement (autre que le logement n° 1)

## Batterie non reconnue

### Écran adjacent au logement

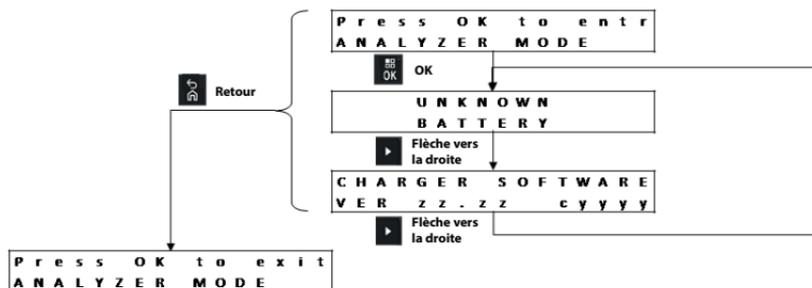

Figure 24 : Menu du mode analyseur de batterie non reconnue à l'écran adjacent au logement

### Le logement n° 1 affiche un autre logement

Le n° du logement (xx) est affiché dans le coin supérieur gauche de l'écran

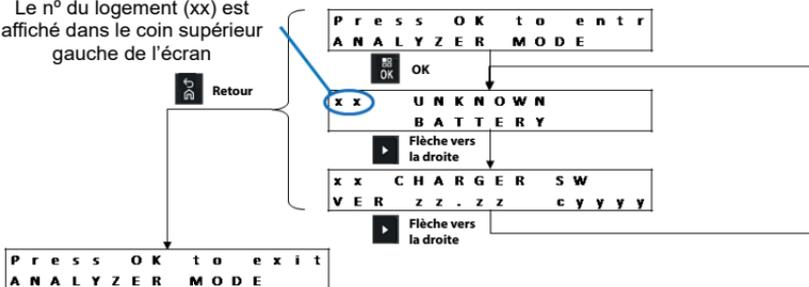
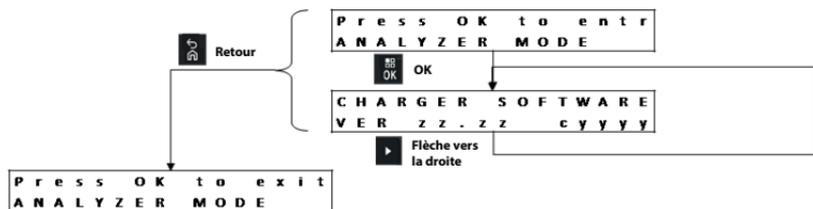

Figure 25 : Menu du mode analyseur de batterie non reconnue pour un autre logement (autre que le logement n° 1)

## Logement vide

### Écran adjacent au logement



**Figure 26 :** Menu du mode analyseur pour un logement vide adjacent à l'écran

### Le logement n° 1 affiche un autre logement

Le n° du logement (xx) est affiché dans le coin supérieur gauche de l'écran

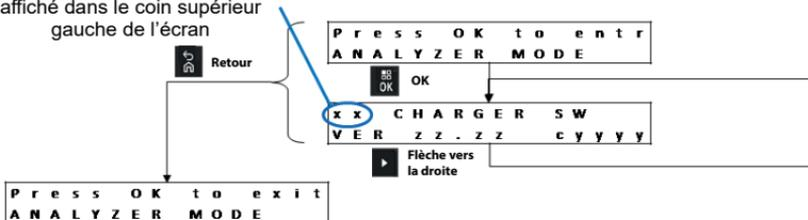

**Figure 27 :** Menu du mode analyseur pour un logement vide (autre que le logement n° 1)

## Message d'état du chargeur

Certaines batteries IMPRES 2 sont dotées d'un mode veille. À la fin de l'opération Expédition lithium, Stockage à long terme xx% ou Stockage à long terme 75 %, la batterie dotée du mode veille est mise en veille. Le message d'état de charge du mode analyseur vous permet de vérifier l'état de charge des batteries en veille.

**Tableau 21 :** Expédition lithium activée et charge de la batterie pour l'opération Expédition lithium achevée

Écran adjacent au logement	Le logement n° 1 affiche un autre logement
SHIP LI SLEEP xxx% Rated Cap	xx SHIP LI SLEEP xxx% Rated Cap



**Tableau 22** : Stockage à long terme xx% activé et charge de la batterie pour l'opération Stockage à long terme xx% achevée :

Écran adjacent au logement	Le logement n° 1 affiche un autre logement
STORAGE SLEEP xxx% Rated Cap	xx STORAGE SLEEP xxx% Rated Cap

Par exemple, le message d'état du chargeur ne s'affiche pas si le Stockage à long terme xx% est activé et que la charge de la batterie pour l'opération Stockage à long terme 75 % a été effectuée dans un autre chargeur.

## Reprogrammation du chargeur

La reprogrammation du chargeur nécessite que le module de communication soit connecté à un ordinateur par un câble USB standard. Lorsque le système de gestion du groupe de batteries IMPRES est utilisé pour effectuer la reprogrammation du chargeur, celui-ci affiche les messages ci-dessous.

Retirez les batteries des logements du chargeur avant la reprogrammation :

```
REPROGRAMMING  
REMOVE BATTERIES
```

Tous les logements sont vides :

```
REPROGRAMMING  
WAITING FOR DATA
```

Données de reprogrammation en téléchargement :

```
REPROGRAMMING  
Progress yyy%
```

Pour les chargeurs avec un écran associé à chaque logement, la valeur de pourcentage est le pourcentage de données téléchargé avec succès dans le logement associé à l'écran. Pour les chargeurs qui ont un seul affichage (logement n° 1), la valeur de pourcentage est le pourcentage de données téléchargé avec succès dans tous les logements.

Échec de la reprogrammation dans le logement identifié :

REPROGRAMMING  
POCKET#xx FAILED

Le logement du chargeur identifié exécute les fonctionnalités normales en utilisant le logiciel précédent.

Le téléchargement des données de reprogrammation est terminé.

Le chargement termine le processus de reprogrammation.

IMPRES 2  
CHARGER

Le processus de reprogrammation est terminé avec succès.

REPROGRAMMING  
COMPLETE

Le chargeur exécute les fonctionnalités normales en utilisant le nouveau logiciel téléchargé. Les réglages définis par l'utilisateur sont conservés une fois que la reprogrammation du chargeur a été achevée.

# Dépannage du chargeur

**Tableau 23 : Dépannage, charge normale**

Problème	Solution
<p>Le voyant du logement ne clignote pas en vert pendant environ 1 seconde lors de la mise sous tension du chargeur.</p>	<p>Assurez-vous que le cordon d'alimentation est bien connecté au chargeur et à une prise c.a. appropriée. Assurez-vous que cette prise est alimentée. Inspectez les fusibles et remplacez-les au besoin.</p>
<p>La batterie ou la radio est insérée dans le logement, mais le voyant du logement reste éteint et la batterie n'est pas identifiée à l'écran adjacent.</p>	<p>Si le logement n'est pas le logement n° 1 et le mode d'économie d'énergie est activé, appuyez sur une touche du menu. Voir ci-dessous.</p>
<p>Le voyant clignote en rouge et l'écran (si disponible) affiche ceci :</p> <p style="text-align: center;">NOT CHARGEABLE REMOVE&amp; REINSERT</p> <p>ou une batterie Motorola Solutions est placée dans le logement, mais l'écran (si disponible) affiche :</p> <p style="text-align: center;">UNKNOWN BATTERY</p>	<p>Retirez la batterie ou la radio du logement.</p> <p>Assurez-vous que les bornes de la batterie et les bornes à l'intérieur du chargeur ne sont pas contaminées, corrodées ou endommagées.</p> <p>Assurez-vous que la batterie est une batterie approuvée par Motorola Solutions. Il est possible que des batteries d'autres types ne puissent pas être chargées.</p> <p>Nettoyez les bornes de la batterie à l'aide d'un chiffon sec. Débranchez le chargeur de la source d'alimentation, puis nettoyez les bornes du logement à l'aide d'un chiffon sec.</p> <p>Essayez de remplacer la batterie. Si le problème disparaît, mettez la batterie défectueuse hors service.</p> <p>Si le problème persiste, même après avoir remplacé la batterie, mettez le chargeur hors service.</p>
<p>Alternance rouge/vert du voyant à la fin de l'étalonnage.</p>	<p>Il est possible que la batterie IMPRES 2 ou IMPRES approche de la fin de sa vie utile. La batterie est utilisable; toutefois, la capacité disponible peut ne pas convenir pour un usage intensif et une période prolongée.</p> <p>Applicable uniquement pour la batterie APX NEXT XN : La batterie a été exposée à des températures élevées pendant plus de 10 minutes. Il est recommandé de retirer cette batterie du service.</p>

**Tableau 23 : Dépannage, charge normale (suite)**

Problème	Solution
Alternance ambre/vert du voyant pendant environ 4 secondes lors de l'insertion de la batterie dans le chargeur. 	La batterie IMPRES 2 ou IMPRES doit être étalonnée/ remise en état. Dès que cela est possible, placez la batterie dans un chargeur IMPRES 2 dont l'étalonnage est activé et attendez que le chargeur ait achevé l'étalonnage de la batterie (vert fixe).
En mode analyseur, le logement n° 1 peut afficher l'information relative à un autre logement.	Le chargeur ne détecte pas l'écran associé à au moins un autre logement.

**Tableau 24 : Dépannage, charge de stockage à long terme**

Problème	Solution
Le voyant clignote en rouge et l'écran (si disponible) affiche ceci : WRONG BATT TYPE CANNOT LT STORE ou CANNOT DISCHARGE CANNOT LT STORE 	Retirez la batterie du logement. Assurez-vous que la batterie N'EST PAS connectée à une radio. Assurez-vous que la batterie est une batterie IMPRES 2 ou IMPRES. Les autres types de batteries ne fonctionneront pas. Nettoyez les bornes de la batterie IMPRES 2 ou IMPRES à l'aide d'un chiffon sec. Débranchez le chargeur de la source d'alimentation, puis nettoyez les bornes du logement à l'aide d'un chiffon sec. Essayez de remplacer la batterie par une autre batterie IMPRES 2 ou IMPRES. Si le problème disparaît, mettez la batterie IMPRES 2 ou IMPRES défectueuse hors service. Si le problème persiste, même après avoir remplacé la batterie IMPRES 2 ou IMPRES, mettez le chargeur hors service.
Le voyant clignote en rouge et l'écran (si disponible) affiche ceci : STORE INCOMPLETE Low Capacity:yy% 	La capacité potentielle de la batterie IMPRES 2 ou IMPRES peut être inférieure à la capacité requise pour l'option de stockage à long terme. La batterie peut approcher de la fin de sa vie utile.

**Tableau 24** : Dépannage, charge de stockage à long terme (suite)

Problème	Solution
<p>Le voyant clignote en rouge et l'écran (si disponible) affiche ceci :</p> <p>RADIO POCKET CANNOT LT STORE</p> <p>ou</p> <p>CHARGING POCKET CANNOT LT STORE</p>	<p>Le logement du chargeur n'est pas le logement standard pour la charge d'une batterie (le contact ne s'établit pas entre les bornes du chargeur et de la batterie).</p> <ul style="list-style-type: none"> <li>• Un logement pour radio est un logement spécial permettant de charger une batterie connectée à une radio; la batterie ne comporte pas de bornes externes et elle est chargée par l'entremise des bornes situées sur la radio.</li> <li>• Un logement de charge utilise l'énergie fournie par le chargeur à des fins particulières, par exemple, en tant que port de recharge USB.</li> </ul> <p>Placez la batterie dans un logement standard ou remplacez le logement pour radio ou de charge par un logement standard.</p>

**Tableau 25** : Dépannage, charge pour Expédition lithium

Problème	Solution
<p>Le voyant clignote en rouge et l'écran (si disponible) affiche ceci :</p> <p>WRONG BATT TYPE CANNOT SHIP LI</p>	<p>Retirez la batterie du logement. Assurez-vous que la batterie N'EST PAS connectée à une radio.</p> <p>Assurez-vous que la batterie est une batterie IMPRES 2 ou IMPRES, ou une autre batterie au lithium-ion approuvée par Motorola Solutions. Les autres types de batteries ne fonctionneront pas.</p> <p>Nettoyez les bornes de la batterie IMPRES 2 ou IMPRES, ou de la batterie au lithium-ion approuvée par Motorola Solutions à l'aide d'un chiffon sec.</p> <p>Débranchez le chargeur de la source d'alimentation, puis nettoyez les bornes du logement à l'aide d'un chiffon sec.</p> <p>Essayez de remplacer la batterie par une autre batterie IMPRES 2 ou IMPRES, ou une autre batterie au lithium-ion approuvée par Motorola Solutions. Si le problème disparaît, mettez la batterie IMPRES 2 ou IMPRES, ou la batterie au lithium-ion approuvée par Motorola Solutions défectueuse hors service.</p> <p>Si le problème persiste avec la nouvelle batterie IMPRES 2 ou IMPRES, ou l'autre batterie au lithium-ion approuvée par Motorola Solutions, mettez le chargeur hors service.</p>

**Tableau 25 : Dépannage, charge pour Expédition lithium (suite)**

Problème	Solution
<p>Le voyant clignote en rouge et l'écran (si disponible) affiche ceci :</p> <p>SHIP INCOMPLETE Low Capacity:yy%</p>	<p>La capacité potentielle de la batterie au lithium-ion Motorola Solutions d'origine peut être inférieure à la capacité requise pour l'option Expédition lithium. La batterie peut approcher de la fin de sa vie utile.</p>
<p>Le voyant clignote en rouge et l'écran (si disponible) affiche ceci :</p> <p>RADIO POCKET CANNOT LT STORE</p> <p>ou</p> <p>CHARGING POCKET CANNOT SHIP LI</p>	<p>Le logement du chargeur n'est pas le logement standard pour la charge d'une batterie (le contact ne s'établit pas entre les bornes du chargeur et de la batterie).</p> <ul style="list-style-type: none"><li>• Un logement pour radio est un logement spécial permettant de charger une batterie connectée à une radio; la batterie ne comporte pas de bornes externes et elle est chargée par l'entremise des bornes situées sur la radio.</li><li>• Un logement de charge utilise l'énergie fournie par le chargeur à des fins particulières, par exemple, en tant que port de recharge USB.</li></ul> <p>Placez la batterie dans un logement standard ou remplacez le logement pour radio ou de charge par un logement standard.</p>

## Système Battery Fleet Management IMPRES

Le logiciel Battery Fleet Management IMPRES collecte automatiquement les données critiques des batteries IMPRES ou IMPRES 2 qui sont insérées dans un chargeur IMPRES. Ces données critiques comprennent l'âge de la batterie, sa capacité, son historique de charge, son historique d'étalonnage/remise en état, sa date de fabrication et sa date de mise en service. Le logiciel IMPRES Battery Fleet Management analyse les données de batterie, communique l'état de la batterie et recommande le moment de remplacer la batterie. Par conséquent, vous pouvez déterminer rapidement et efficacement s'il est nécessaire de réattribuer la batterie à un utilisateur moins exigeant, d'acheter une batterie de rechange ou de localiser une batterie manquante.

Le logiciel Battery Fleet Management IMPRES offre des informations essentielles sur la batterie :

- Indique quand les batteries sont en dessous d'une capacité acceptable.
- Permet de garantir que les utilisateurs ont une capacité suffisante pour un quart de travail entier.
- Identifie les batteries à faible capacité afin qu'elles puissent être retirées du service.
- Élimine les temps d'arrêt imprévus et les interruptions de travail.
- Évite les frais liés à la mise au rebut prématurée des batteries.
- Confirme que les chargeurs sont distribués et utilisés de façon optimale.

Le logiciel IMPRES Battery Fleet Management est une application évolutive qui peut être étendue d'un système de site unique à un système réseau multisite, comme représenté dans la Figure 28. Le système Battery Fleet Management IMPRES prend en charge :

- un serveur administrateur de système;
- 19 clients distants;
- 25 chargeurs IMPRES ou lecteurs de batterie IMPRES par clients;
- 25 000 batteries IMPRES dans un emplacement unique ou réparties dans des secteurs géographiquement éloignés (le nombre total de batteries pour le système en entier ne peut pas dépasser 25 000).

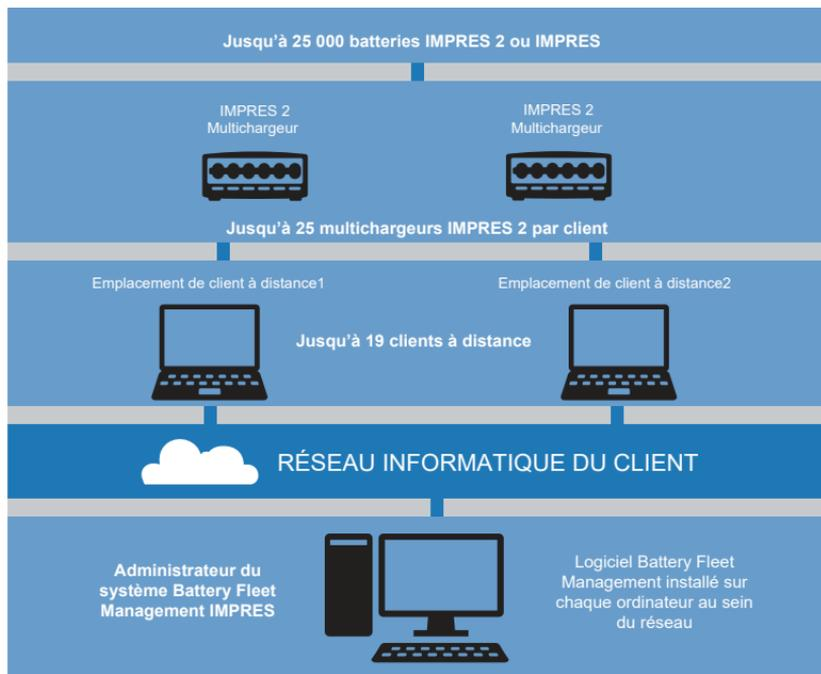

**Figure 28 :** Battery Fleet Management IMPRES par des chargeurs réseau

Le système Battery Fleet Management IMPRES comprend trois éléments :

- Le logiciel d'application.
- La clé de licence logicielle.
- Un câble USB reliant le chargeur IMPRES 2, le module de communication IMPRES 2, l'unité d'interface du chargeur (CIU) IMPRES ou le lecteur de données de batterie IMPRES à un ordinateur hébergeant un client distant.



Il utilise des rapports existants pour personnaliser les nouveaux modèles afin de voir les informations les plus pertinentes pour votre organisation. Les données sont stockées dans votre base de données et peuvent être exportées dans un fichier Excel™ ou imprimées. Le logiciel IMPRES Battery Fleet Management enregistre et organise une variété de données pour que vous puissiez faire ce qui suit :

- Voir un instantané de l'état de votre groupe de batteries entier.
- Évaluer si les batteries répondent à vos critères de rendement.
- Déterminer lorsque les batteries approchent leur fin de vie.
- Décider exactement le moment d'acheter de nouvelles batteries.
- Obtenir un rapport sur les batteries perdues.
- Optimiser l'utilisation du chargeur.
- Surveiller tous les dispositifs du système.

Serial Number	Alias	Group	Radio Family	IIS Number	Chemistry	Fitted	Potential Capacity	Date of First Use
5000000247478	Sam	Building 1	WTS 3000/3000/3000	HWN06118	NaCl	No	1523	1/9/2009
5000000248440	Matt	Security	APR	WNTN7973A	NaISe	No	1480	12/11/2008
5000000248448	Inf-Inf	Security	APR	WNTN7973A	NaISe	Yes	2000	2/14/2007
5000000282521	Phil	Administration	HTCG/PRO Series	HWN06248	NaCl	No	1350	2/4/2009
5000000281122	Patte	Building 1	WTS 3000/3000/3000	WNTN4407B	NaISe	Yes	1700	1/14/2008
5000000242955	Steve	Building 1	WTS 2500, WTS/MF/JR 1550	WNTN7974A	Li-Ion	No	2000	1/24/2009
5000000248461	Adam	None	Galve	HWN06126	NaCl	No	2400	9/25/2009
5000000248473	Mark	Building 2	WTS 2500, WTS/MF/JR 1550	WNTN7974A	Li-Ion	No	2000	1/11/2008
5000000282521	Gene	Building 2	WTS 2500, WTS/MF/JR 1550	WNTN7974A	Li-Ion	Yes	2400	1/21/2009
5000000281200	Bob	None	Galve	HWN06126	NaCl	Yes	2400	1/25/2008
5000000302111	Carroll	Administration	HTCG/PRO Series	HWN06248	NaISe	Yes	1800	11/12/2009
5000000412807	Phil	Building 1	WTS 3000/3000/3000	WNTN4407B	NaISe	Yes	1700	12/11/2008
5000000481380	Joe	Building 1	WTS 3000/3000/3000	HWN06118	NaCl	No	1623	10/17/2009
5000000489939	BB	Security	APR	WNTN7973A	Li-Ion	Yes	1400	7/21/2009
5000000490220	Frank	Security	APR	WNTN7973A	NaISe	No	2100	12/11/2008
5000000423258	Eric	Maintenance	MCTC77800	PRN04677A	Li-Ion	No	2120	12/8/2009
5000000461707	Mark	Building 2	WTS 3000/3000/3000	WNTN7433A	Li-Ion	Yes	3900	10/14/2009
5000000461708	Henry	Administration	HTCG/PRO Series	HWN06248	NaCl	No	1160	7/10/2009
5000000462411	Phil	Building 1	APR	WNTN7973A	NaISe	No	2100	1/9/2008
5000000462412	Tom	Security	APR	WNTN7973A	Li-Ion	Yes	1400	1/14/2009
5000000462417	John	Maintenance	HTCG/PRO Series	HWN06248	NaCl	No	1350	1/21/2009
5000000462421	Steve	Building 2	WTS 3000/3000/3000	PRN04683A	NaISe	No	2070	8/6/2007
5000000424138	Phil	Administration	MCTC77800	PRN04665A	Li-Ion	Yes	1400	8/12/2008
5000000424133	Frank	Building 1	APR	WNTN7973A	NaISe	Yes	2100	1/25/2008
5000000424132	Tom	Security	MCTC77800	PRN04665A	Li-Ion	Yes	1400	8/12/2007
5000000424131	Henry	Maintenance	APR	WNTN7973A	NaISe	No	2100	1/21/2008
5000000424130	Sam	Building 2	HTCG/PRO Series	HWN06248	NaISe	No	2140	10/12/2007
5000000424129	Steve	Security	WTS 3000/3000/3000	WNTN6144A	Li-Ion	No	1610	1/16/2008
5000000424128	Mark	Administration	APR	WNTN7973A	NaISe	No	1440	1/21/2008
5000000424127	Mark	Building 1	MCTC77800	PRN04665A	Li-Ion	No	1300	10/11/2007

Figure 29 : Rapport de batterie active

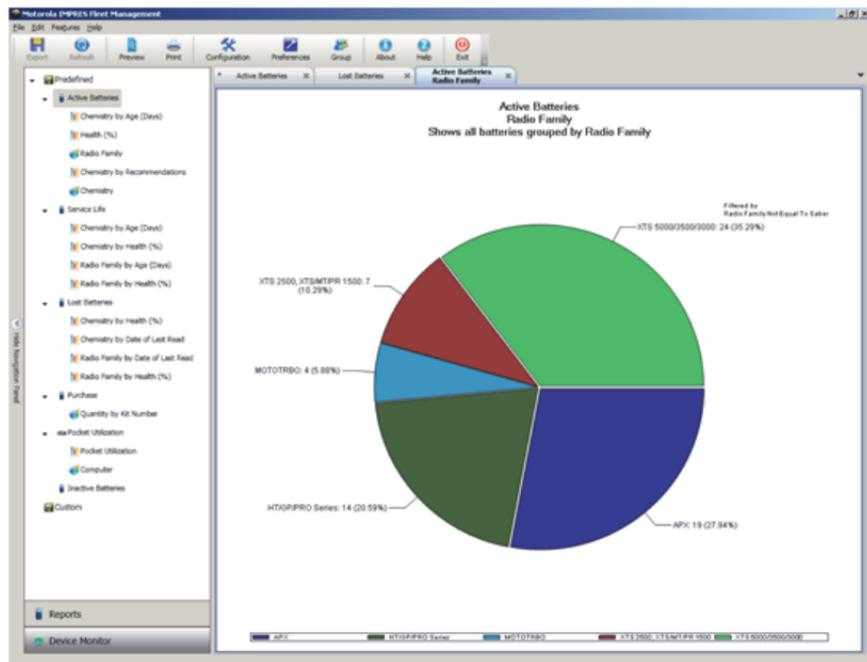

Figure 30 : Batteries utilisées par la famille de radios

Metastudio (SRM) Fleet Management

File Edit Preferences Group Help Exit

Export Refresh Printer View Configuration Preferences Group Help Exit

Active Batteries Active Batteries by Health (7%) Lost Batteries

Serial Number	Make	Group	Radio Family	Alt Number	Chemistry	Age	Rated Capacity	Potential Capacity	Date of Next Use	Recommendations	Days since Last Used	Age
00000101494	Sierra	Building 1	475 5000 10000 0000	000001010	Ni-Cd	No	1420	1411	6/1/2008	Recharge / Calibrate Battery	160	101
00000101512	Sierra	Building 1	475 5000 10000 0000	000001010	Ni-Cd	Yes	1750	1750	6/16/2008	No Recommendations	160	9
00000101498	Sierra	Building 1	475 5000 10000 0000	000001010	Ni-Cd	No	1000	1000	1/24/2008	No Recommendations	160	34
00000101487	Sierra	Building 1	475 5000 10000 0000	000001010	Ni-Cd	Yes	1750	1757	10/20/2008	No Recommendations	160	71
00000101492	Sierra	Building 1	475 5000 10000 0000	000001010	Ni-Cd	No	1000	1000	6/1/2008	No Recommendations	160	71
00000101490	Sierra	Building 1	475 5000 10000 0000	000001010	Ni-Cd	No	1000	1000	6/1/2008	No Recommendations	160	9
00000101494	Sierra	Building 1	475 5000 10000 0000	000001010	Ni-Cd	No	1000	1000	1/24/2008	No Recommendations	160	71
00000101491	Sierra	Building 1	475 5000 10000 0000	000001010	Ni-Cd	No	1000	1000	7/1/2008	No Recommendations	160	30
00000101493	Sierra	Administration	475 5000 10000 0000	000001010	Ni-Cd	No	1000	1000	5/1/2008	No Recommendations	160	0

No Recommendations

Device Monitor

Figure 31 : Batterie perdue par emplacement

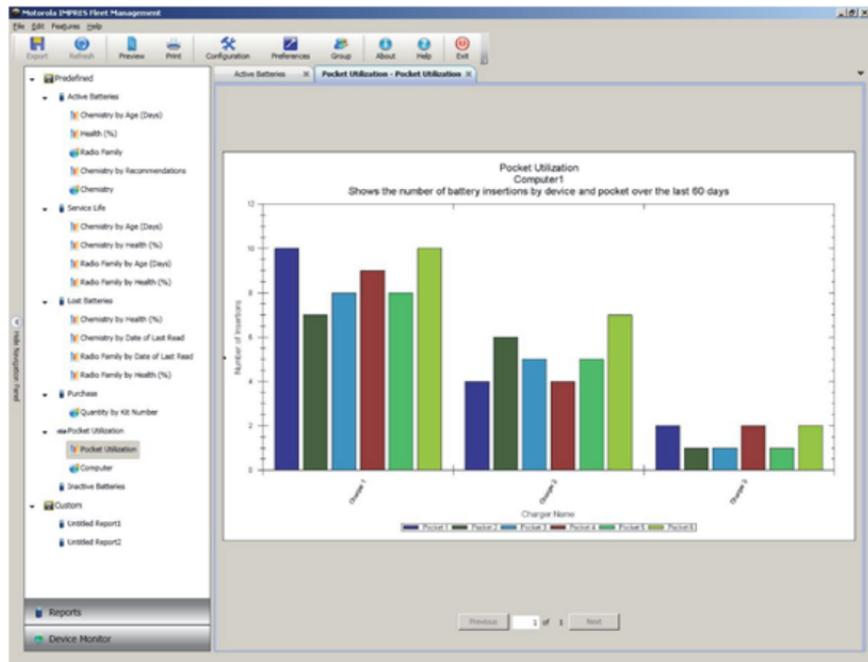

Figure 32 : Utilisation de logement par chargeur

## Fixation murale pour multichargeur

Un support de fixation murale (numéro de pièce : 0705559L01) est disponible pour le multichargeur. Communiquez avec votre détaillant local pour commander cet article. L'installation est illustrée ci-dessous.



AVERTISSEMENT

- Ce support de fixation murale doit être installé par un technicien qualifié et expérimenté. Faire installer le produit par un technicien non spécialisé est très dangereux et peut causer des dommages ou des blessures.
- N'installez pas le produit là où son poids ne peut pas être supporté. Si l'emplacement où le support est installé n'est pas assez solide, il peut tomber et causer des blessures.
- Ne l'installez pas sur une structure qui est sujette à des vibrations ou à des mouvements, ou qui risque de subir des impacts.

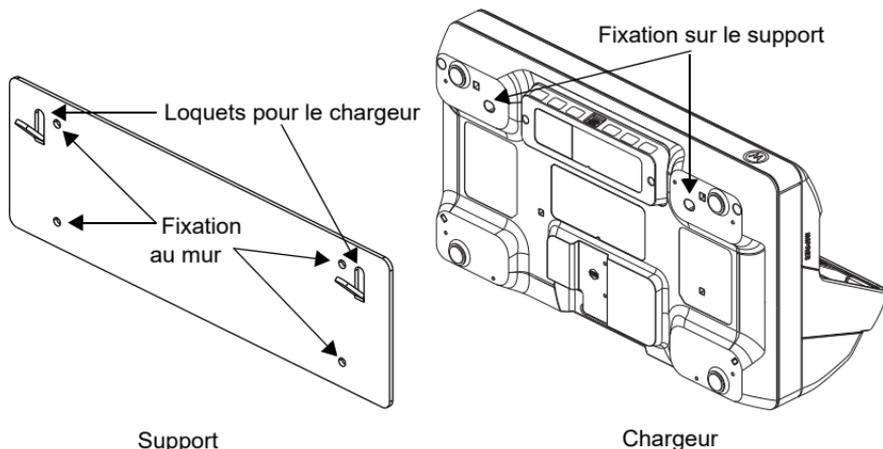

**Figure 33** : Trous de montage du support et position des loquets

## Montage du multichargeur au support de fixation murale

1. Placez le support de fixation murale dans la position désirée et marquez l'emplacement des trous de montage sur la surface du mur.



Assurez-vous que la zone située derrière la surface de montage est bien libre de fils électriques, de câbles et de tuyaux avant de couper, percer ou installer les vis de montage.

2. Fixez le support au mur à l'aide du matériel de fixation requis pour le type de mur sur lequel vous l'installez. Percez les trous en fonction des marques que vous avez faites sur le mur.
3. Fixez le support en position en installant solidement le matériel de montage sur les trous de montage du support mural.

**Remarque :** Il est recommandé d'utiliser des vis autotaraudeuses et des boulons 10-16x1,5 po (non inclus) sur des crampons à bois et un mur de béton ou de briques plat.

4. Accrochez le multichargeur sur le support de fixation murale.

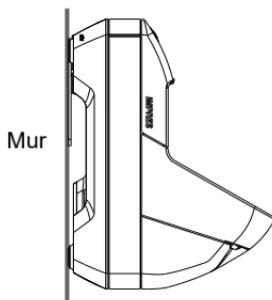

**Figure 34 :** Chargeur monté sur support de fixation murale

## Remarques

# INSTRUCCIONES DE SEGURIDAD IMPORTANTES

## Guarde estas instrucciones

Este documento contiene instrucciones de seguridad y funcionamiento importantes. Lea estas instrucciones atentamente y consérvelas para referencia futura.

Antes de usar el cargador de batería, lea todas las instrucciones y las marcas de advertencia en (1) el cargador, (2) la batería y (3) el radio que utiliza la batería.



ADVERTENCIA

1. Para reducir el riesgo de daños en el cable de alimentación, tire del enchufe en lugar del cable cuando lo desconecte de la toma de corriente de CA o del cargador.
2. No se debe utilizar un cable de extensión, a menos que sea completamente necesario. El uso de un cable de extensión no adecuado podría ocasionar riesgo de incendio y descarga eléctrica. Si se debe utilizar un cable de extensión, asegúrese de que el tamaño del cable sea de 18 AWG para longitudes de hasta 2,0 m (6,5 pies) y de 16 AWG para longitudes de hasta 3,0 m (9,8 pies).
3. Para reducir el riesgo de incendio, descarga eléctrica o lesiones, no utilice el cargador si está roto o dañado. Llévelo a un representante de mantenimiento calificado de Motorola Solutions.
4. No desarme el cargador. Si desarma el cargador, se puede generar un riesgo de descarga eléctrica o incendio. Las únicas piezas reparables o de repuesto son las inserciones de cavidades NNTN9212 y NNTN9213. Siga las instrucciones de los kits de inserción de cavidades de carga para varias unidades MN005697A01 IMPRES 2 serie APX.
5. Para reducir el riesgo de descarga eléctrica, desconecte la fuente de alimentación del cargador de la toma de corriente de CA antes de realizar cualquier tipo de mantenimiento o limpieza.



6. Para reducir el riesgo de lesiones, cargue solo las baterías recargables autorizadas por Motorola Solutions que se indican en la Tabla 2. Otras baterías pueden explotar, lo que puede causar lesiones personales y daños.
7. El uso de accesorios no recomendados por Motorola Solutions puede ocasionar un riesgo de incendio, descarga eléctrica o lesiones.

## **Pautas de seguridad operativa**

- Este equipo no debe utilizarse en áreas exteriores. Utilícelo solo en lugares o condiciones secos.
- La temperatura ambiente máxima alrededor del cargador no debe exceder los 40 °C (104 °F).
- Cuando un radio se encuentre en una cavidad de carga, puede estar ENCENDIDO solo si está transmitiendo datos de forma inalámbrica, como a través de Wi-Fi. De lo contrario, APAGUE el radio.
- Conecte el cargador solo a una fuente de alimentación adecuada, como se indica en la Tabla 3.
- La toma de corriente de CA, en la que está conectado el cable de alimentación, debe estar cerca de este y debe ser de fácil acceso.
- Asegúrese de que el cable de la fuente de alimentación conectado al cargador se ubique en lugares donde las personas no puedan pisarlo ni tropezarse con él, o en lugares donde no esté expuesto a agua, daños ni tensión.
- Conecte el cable de alimentación solo a una toma de corriente de CA con fusibles y cable con el voltaje correcto, tal y como se especifica en el producto.
- Para desconectar el voltaje de línea, retire el cable de alimentación de la toma de corriente de CA.
- Conecte solamente la cantidad apropiada de cargadores a un circuito de 15 A o 20 A, según el límite de la extensión eléctrica certificada que se utilice. NO SE RECOMIENDA el uso de extensiones eléctricas de conexión en cadena. Limite la carga del circuito por debajo del 80 % de la calificación del circuito.
- Utilice únicamente cavidades autorizadas por Motorola Solutions.

## Modelos compatibles

**Tabla 1:** Modelos compatibles y descripción

Modelo	Descripción
PS000029A01 (UNIV) PS000029A04 (UE/RU) PS000029A06 (KR)	Cargador de 1 pantalla IMPRES 2 APX para varias unidades con reprogramación de cargador y administración de flotas.
PS000029A02 (UNIV) PS000029A05 (UE/RU) PS000029A07 (KR)	Cargador de 6 pantallas IMPRES 2 APX para varias unidades con reprogramación de cargador y administración de flotas.
PS000029A03 (UE/RU) PS000029A08 (KR)	Cargador de 6 pantallas IMPRES 2 APX para varias unidades con reprogramación de cargador, administración de flotas y carga de accesorios USB.
PS000337A01 (EE. UU./NA, AU/NZ)	Cargador de 6 pantallas IMPRES 2 APX NEXT para varias unidades con reprogramación de cargador y administración de flotas.

## Baterías autorizadas por Motorola Solutions

Los cargadores IMPRES 2 serie APX cargan las baterías que se indican en la Tabla 2. Es posible que las baterías estén conectadas a un radio o de manera independiente.

**Tabla 2:** Baterías autorizadas por Motorola Solutions

Kit (NP)	Descripción
NNTN7033	IMPRES de iones de litio, FM (HazLoc), IP67, 4100 mAh
NNTN7034	IMPRES de iones de litio, IP67, 4200 mAh
NNTN7035	IMPRES de NiMH, FM (HazLoc), resistente, 2000 mAh
NNTN7036	IMPRES de NiMH, FM (HazLoc), IP67, 2000 mAh
NNTN7037	IMPRES de NiMH, IP67, 2100 mAh
NNTN7038	IMPRES de iones de litio, IP67, 2900 mAh
NNTN7573	IMPRES de NiMH, resistente, 2100 mAh
NNTN8092	IMPRES de iones de litio, FM (HazLoc), resistente, 2300 mAh
NNTN8182	IMPRES de iones de litio, resistente, 2900 mAh
NNTN8921	IMPRES 2 de iones de litio, TIA4950 (HazLoc), resistente, IP67, 3700 mAh
NNTN8930	IMPRES 2 de iones de litio, TIA4950 (HazLoc), resistente, IP67, 2700 mAh

**Tabla 2:** Baterías autorizadas por Motorola Solutions (continuación)

Kit (NP)	Descripción
NNTN9087	IMPRES 2 de iones de litio, IP68, 3800 mAh
NNTN9088	IMPRES 2 de iones de litio, DIVISIÓN 2 (HazLoc), IP68, 3800 mAh
NNTN9089	IMPRES 2 de iones de litio, IP68, 5650 mAh
NNTN9090	IMPRES 2 de iones de litio, DIVISIÓN 2 (HazLoc), IP68, 5650 mAh
NNTN9126	IMPRES 2 de iones de litio, IP68, 4400 mAh
NNTN9127	IMPRES 2 de iones de litio, DIVISIÓN 2 (HazLoc), IP68, 4400 mAh
PMNN4403	IMPRES de iones de litio, IP67, 2150 mAh
PMNN4485	IMPRES 2 de iones de litio, resistente, IP67, 2500 mAh
PMNN4486	IMPRES 2 de iones de litio, resistente, IP67, 3400 mAh
PMNN4487	IMPRES 2 de iones de litio, resistente, IP67, 4400 mAh
PMNN4494	IMPRES 2 de iones de litio, resistente, IP67, 5000 mAh
PMNN4504	IMPRES 2 de iones de litio, DIVISIÓN 2 (HazLoc), resistente, IP67, 3400 mAh
PMNN4505	IMPRES 2 de iones de litio, DIVISIÓN 2 (HazLoc), resistente, IP67, 4850 mAh
PMNN4547	IMPRES 2 de iones de litio, TIA4950 (HazLoc), resistente, IP68, 3100 mAh
PMNN4573	IMPRES 2 de iones de litio, TIA4950 (HazLoc), resistente, IP68, 4600 mAh
PMNN4812	APX NEXT XN IMPRES 2 de iones de litio, DIV. 2 (HAZLOC), IP68, 3400 mAh

## Accesorios de alimentación autorizados por Motorola Solutions

**Tabla 3:** Accesorios de alimentación autorizados por Motorola Solutions

Kit (NP)	Descripción
3087791G01	Cable de alimentación para EE. UU./NA
3087791G04	Cable de alimentación para UE
3087791G07	Cable de alimentación para RU/HK
3087791G10	Cable de alimentación para AU/NZ
3087791G13	Cable de alimentación para AR

**Tabla 3:** Accesorios de alimentación autorizados por Motorola Solutions (continuación)

Kit (NP)	Descripción
3087791G16	Cable de alimentación para KR
3087791G20	Cable de alimentación para JP
3087791G22	Cable de alimentación para BR
CB000460A01	Cable de alimentación para CH

## Módulos de comunicaciones autorizados por Motorola Solutions

**Tabla 4:** Módulos de comunicaciones autorizados por Motorola Solutions

Kit (NP)	Descripción
AS000013A01	Módulo de administración de flotas de baterías y reprogramación de cargadores IMPRES 2
AS000012A02	Módulo de carga de accesorios y administración de flotas de baterías/reprogramación de cargadores IMPRES 2

## Cargador, cavidad y módulo de comunicaciones

El sistema de cargador adaptable IMPRES 2™ de la serie APX es un sistema de cuidado de la batería totalmente automático. El cargador cuenta con las siguientes funciones:

- La carga adaptable admite una amplia variedad de tipos de batería, incluidas IMPRES 2 e IMPRES™, así como otras baterías originales de Motorola Solutions.
- Cavidad que se adapta tanto a una batería independiente como a un radio con una batería conectada.
- El estado de la cavidad del cargador se indica con un LED de color rojo, ámbar o verde.
- Módulo de comunicaciones
  - Reprogramación del cargador
  - Los datos de la batería IMPRES o IMPRES 2 se cargan a un sistema de administración de flota de baterías IMPRES
  - (Opcional) Seis puertos de carga USB de tipo A, cada uno con 0,5 A para carga de un accesorio USB
- Menú de teclado
  - Configuración del cargador
  - Análisis de la batería

- Pantalla de información en la cavidad n.º 1.
  - Pantallas opcionales en otras cavidades
- Preparación de una batería independiente IMPRES 2 o IMPRES para almacenamiento o preparación a largo plazo de una batería de iones de litio independiente de Motorola Solutions para su envío. NO deje las baterías en el cargador después de la preparación para el almacenamiento a largo plazo ni después de que se haya completado el envío de la batería de iones de litio.
- Funciones de eficiencia energética
  - Cumple con los estándares de aparatos de la Comisión de Energía de California para sistemas pequeños de carga de batería. Las cavidades del cargador se pondrán automáticamente en modo inactivo y, luego, se activarán para responder a una acción por parte del usuario o para cargar una batería en la cavidad.
  - Cumple con los límites europeos de corriente en espera (kit de cargador europeo). Cuando se activa el modo de ahorro de energía, todas las cavidades del cargador, excepto la cavidad n.º 1, se apagan automáticamente cuando no hay actividad durante un período. Si se presiona cualquier botón del teclado, se encienden las cavidades nuevamente.
- Mayor tasa de carga de la batería de iones de litio IMPRES 2.
- Carga más rápida.
- Ciclo prolongado de duración de la batería.

No se recomienda operar el radio mientras está conectado al cargador.

Durante el proceso de carga, el funcionamiento del radio puede provocar una disminución mínima del rendimiento del radio y un mayor tiempo de carga de la batería.

Durante el proceso de calibración/reacondicionamiento, la batería se descarga por completo antes de cargarse completamente. Como resultado de ello, es posible que el radio se apague durante la fase de descarga. Se recomienda calibrar la batería sin que el radio esté conectado o con el radio conectado y apagado.

# Baterías y cargadores IMPRES e IMPRES 2

## Funciones y beneficios

La solución de energía IMPRES 2 es un avanzado sistema de energía de química triple desarrollado por Motorola Solutions. Este sistema incluye lo siguiente:

- Baterías IMPRES e IMPRES 2
- Cargador adaptable IMPRES 2
- Radios IMPRES

Cargar baterías IMPRES o IMPRES 2 con un cargador adaptable IMPRES 2, que calibra o reacondiciona periódicamente la batería, proporciona las siguientes ventajas:

- Prolonga la vida útil de la batería.
- Mide la capacidad de la batería y determina el estado de carga actual de la batería, lo que proporciona una indicación del tiempo de uso real.
- Monitorea el patrón de uso de las baterías IMPRES o IMPRES 2.
- Actualiza la información del patrón almacenada en las baterías IMPRES o IMPRES 2.
- Realiza automáticamente la calibración o el reacondicionamiento solo cuando es necesario.
- Minimiza la temperatura de las baterías IMPRES o IMPRES 2, independientemente del tiempo que se deje en la cavidad.
- Recarga periódicamente una batería almacenada en la cavidad del cargador, lo que la mantiene lista para el usuario.
- Elimina el efecto de memoria de las baterías de níquel, por lo que no hay necesidad de comprar equipos especiales ni capacitar al personal en tareas de mantenimiento del ciclo de vida de la batería.

Con este sistema único y patentado, no es necesario realizar un seguimiento y registrar el uso de las baterías IMPRES o IMPRES 2, realizar la calibración o el reacondicionamiento manualmente ni extraer las baterías de los cargadores una vez terminada la carga.

## Inicialización de las baterías IMPRES o IMPRES 2

Para obtener la funcionalidad completa de IMPRES o IMPRES 2, el cargador debe inicializar una nueva batería IMPRES o IMPRES 2. El cargador detecta de forma automática la nueva batería IMPRES o IMPRES 2 y comienza automáticamente la inicialización. La inicialización es el primer reacondicionamiento/calibración de una batería IMPRES o IMPRES 2. Es un proceso de dos fases. La primera fase es la descarga de la batería, que se indica mediante una luz LED en **ámbar fijo**. La segunda fase es la carga completa, que se indica, al terminar, mediante una luz LED en **verde fijo**. Este proceso puede tardar hasta 12 horas o más en completarse, según el estado de carga y la capacidad de la batería. La interrupción de cualquiera de las fases demora la inicialización hasta la siguiente oportunidad de carga.

## Función de cavidad a cavidad IMPRES o IMPRES 2

Quando se cargan baterías IMPRES o IMPRES 2, los cargadores IMPRES o IMPRES 2 registran la información de carga en la memoria de la batería. Si se quitan las baterías IMPRES o IMPRES 2 de la cavidad de los cargadores IMPRES o IMPRES 2 y, dentro de 30 minutos, estas se colocan en la misma cavidad u otra cavidad de un cargador IMPRES o IMPRES 2, entonces la carga se reanudará en el punto en que se interrumpió. Esta función evita la sobrecarga de la batería y minimiza la pérdida del ciclo de vida útil. Esto es especialmente importante cuando se cargan baterías de níquel.

## Calibración o reacondicionamiento automático de las baterías IMPRES o IMPRES 2

El cargador IMPRES 2 evalúa automáticamente la condición de una batería IMPRES o IMPRES 2. Con base en esta condición, el cargador calibra/reacondiciona automáticamente la batería. La interrupción de la fase de descarga o de la fase de carga completa posterga la calibración hasta la siguiente oportunidad de carga.

Utilice el modo de configuración del cargador para activar o desactivar la calibración o el reacondicionamiento. Cuando se desactiva esta función y las baterías IMPRES o IMPRES 2 requieren calibración o reacondicionamiento, la luz LED se muestra de manera **alternada** entre **ámbar y verde** cuando se inserta la batería y cuando ya está cargada.

**Nota:** Las baterías IMPRES o IMPRES 2 deben estar fuera de la cavidad del cargador durante más de 30 minutos para la calibración o el reacondicionamiento automáticos.

## Batería IMPRES con autocalibración y reacondicionamiento



**ATENCIÓN:** Las baterías IMPRES 2 que tienen este ícono en la etiqueta de la batería no requieren calibración ni reacondicionamiento periódicos cuando se acoplan a este cargador IMPRES 2 (con la versión de software V2.05 o una posterior).

**Nota:** Asegúrese de que el cargador esté siempre actualizado con el firmware más reciente. El paquete de aplicaciones del Reprogramador de cargador de MSI se puede descargar de Motorola Online (MOL) o el sitio web de Motorola Solutions.

## Actualización del firmware

**Nota:** Se aplica a todos los dispositivos o cargadores IMPRES Gen 1 y Gen 2; esto incluye la unidad de interfaz de cargador (CIU), el lector de datos de batería (BDR), el cargador para una unidad (SUC), el cargador para dos unidades (DUC) y el cargador para varias unidades (MUC).

Retire todas las baterías insertadas del dispositivo de destino o el cargador antes de actualizar un dispositivo o cargador IMPRES a una versión más reciente.



1. Conecte el dispositivo o cargador a su computadora mediante una conexión USB. El dispositivo o cargador conectado se muestra en la ventana principal del Reprogramador del cargador MSI.

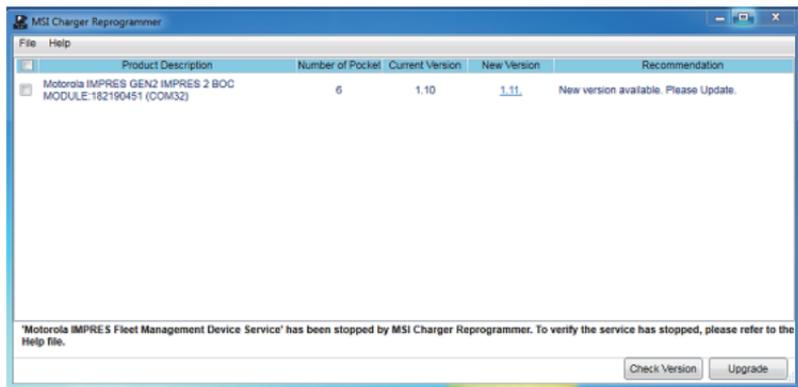

2. Haga clic en Comprobar versión para encontrar la última versión disponible del servidor MSI.

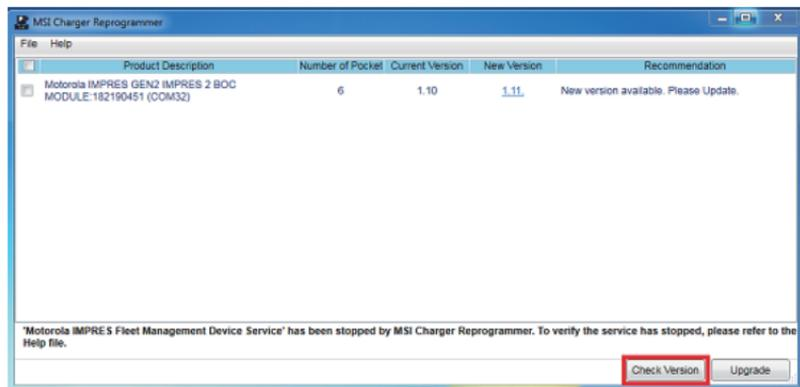

### 3. Seleccione el dispositivo o cargador que requiere actualización.

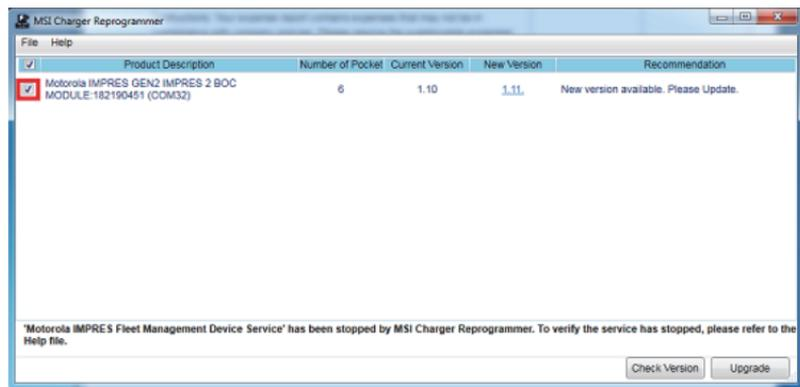

**Nota:** No puede seleccionar un dispositivo ni un cargador ya actualizado con la versión de firmware más reciente.

### 4. Para iniciar la actualización del firmware, haga clic en Actualizar.

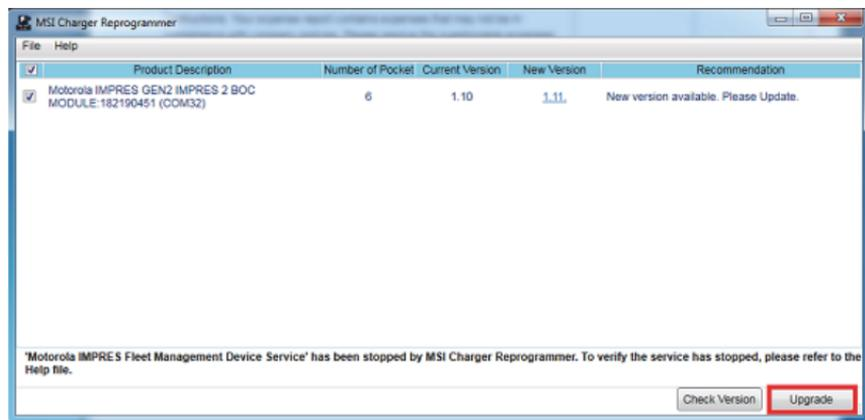

5. Haga clic en Aceptar en la ventana de confirmación cuando se le solicite iniciar la actualización. Una ventana muestra el progreso de la actualización hasta su finalización.

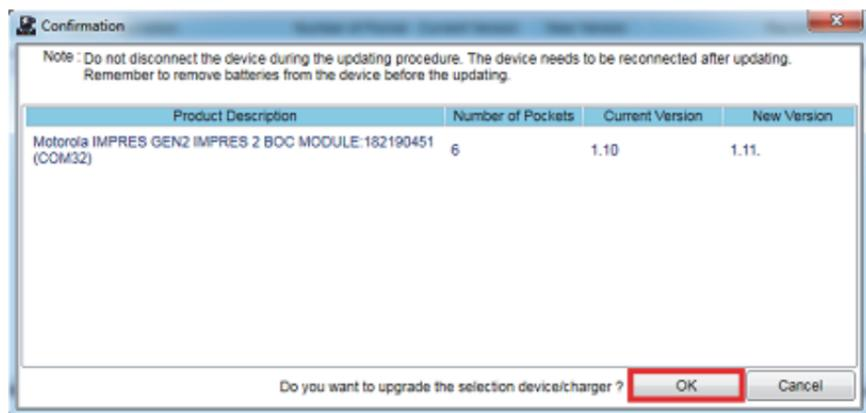

6. Cierre la ventana una vez que se completan todas las actualizaciones.

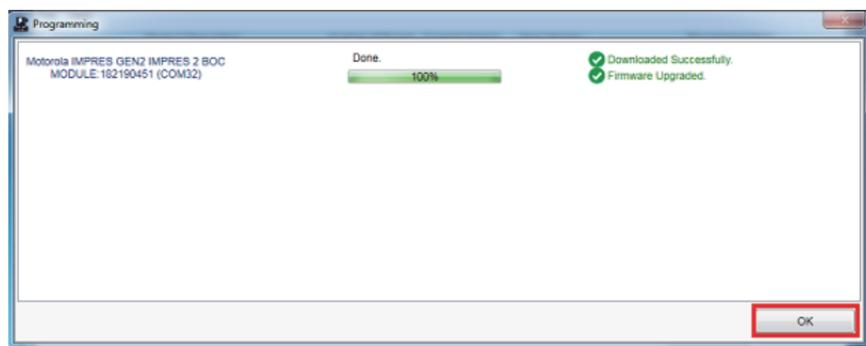

## Inicialización manual de la calibración o el reacondicionamiento



**ATENCIÓN:** La calibración manual o el reacondicionamiento no se aplican a las baterías IMPRES o IMPRES 2 que tienen este ícono.

Aunque la calibración o el reacondicionamiento son procesos automáticos, es posible que haya situaciones en las que se desee iniciarlos manualmente. Por ejemplo, el cargador puede **alternar entre ámbar y verde** para las baterías IMPRES o IMPRES 2 cuando se desactiva la calibración en el cargador. Si esa batería se coloca dentro de 30 minutos en un cargador que tenga la calibración activada, se reanudará el último estado de carga, lo cual evita el inicio automático de la calibración o el reacondicionamiento.

Para iniciar manualmente la calibración o el reacondicionamiento, quite las baterías IMPRES o IMPRES 2 del cargador durante más de dos minutos y medio. Luego, siga estos pasos:

1. Inserte la batería en la cavidad de carga.
2. En dos minutos y medio, retire la batería de la cavidad del cargador.
3. En cinco segundos, vuelva a insertar la batería en la cavidad del cargador.

La calibración o el reacondicionamiento se iniciarán de forma inmediata, por lo general, con la descarga de la batería (**ámbar fijo**).

La calibración o el reacondicionamiento solo terminan una vez que se ha realizado la carga completa (**verde fijo**).

### **Finalización manual de la calibración o el reacondicionamiento**

En cualquier momento durante la descarga de las baterías IMPRES o IMPRES 2 (**ámbar fijo**), para finalizar la calibración o el reacondicionamiento, siga los pasos que se indican a continuación:

1. Retire la batería de la cavidad del cargador.
2. En cinco segundos, vuelva a insertar la batería en la cavidad del cargador.

La descarga de la batería termina inmediatamente y se inicia la carga normal de la batería. El LED indica el estado de la carga.

# Esquema del cargador

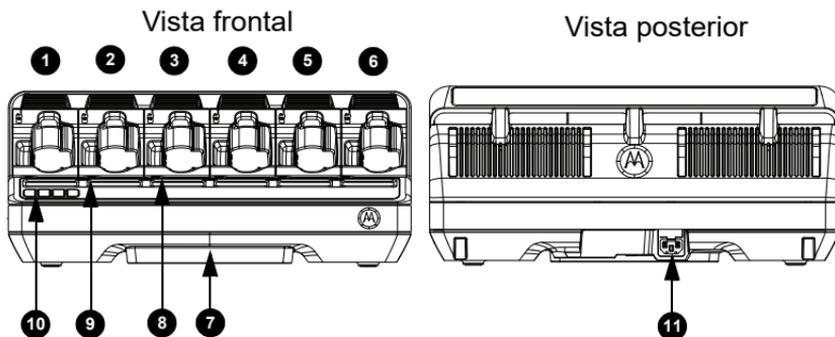

**Figura 1:** Esquema del cargador

**Tabla 5:** Descripciones generales y específicas del cargador

N.º	Nombre	Descripción
1–6	Cavidades del cargador	Cada cavidad se adapta a un radio compatible o a una batería independiente
7	Módulo de comunicaciones	En ciertos cargadores, el módulo de comunicaciones también carga accesorios USB: <ul style="list-style-type: none"> <li>• UE/RU PS000029A03</li> <li>• KR PS000029A08</li> </ul>
8	Indicador de estado del LED de la cavidad	LED de estado de carga (uno por cavidad)
9	Pantalla	Pantalla opcional para las cavidades distintas de la cavidad n.º 1
10	Pantalla del teclado	Pantalla de la cavidad n.º 1 con teclado de menú
11	Enchufe de la entrada de corriente de CA	Utiliza un cable de alimentación específico para el país o la región

## Indicación LED sobre el fin de la vida útil de IMPRES o IMPRES 2

En el cargador, se puede indicar el fin de la vida útil de la batería IMPRES o IMPRES 2 (**alternando entre rojo y verde**) cuando se completan correctamente la calibración o el reacondicionamiento.

A medida que se utilizan las baterías, el desgaste normal reduce la capacidad disponible. Después de realizar correctamente la calibración o el reacondicionamiento, el cargador compara la capacidad de la batería IMPRES o IMPRES 2 con la potencia nominal de la batería. Cuando la capacidad se encuentra en un valor muy bajo, es posible que las baterías IMPRES o IMPRES 2 estén llegando al final de su vida útil. Las baterías IMPRES o IMPRES 2 siguen siendo utilizables. En algunas situaciones, puede ser mejor asignar la batería a alguien que no requiera una gran capacidad de batería para completar un turno de trabajo.

La batería APX NEXT XN viene con una función de detección de alta temperatura que se puede detectar desde el cargador IMPRES 2 con la versión de software V2.05 o una posterior. Cuando esta función está activada, el LED de estado parpadea en rojo y verde de forma alternada al finalizar la carga de la batería que pasó por una exposición prolongada en un entorno a temperaturas extremadamente altas. En el cargador se muestra lo siguiente:

REPLACE BATTERY  
EXPOSED OVERTEMP

Se recomienda retirar esta batería del servicio.

## Carga de las baterías o los radios con baterías conectadas

Las baterías se cargan mejor a temperatura ambiente. Los cargadores para varias unidades IMPRES 2 pueden cargar una batería independiente o una batería conectada a un radio.

1. Coloque el cargador sobre una superficie horizontal.
2. Inserte con firmeza el cable de alimentación en el enchufe de la entrada de corriente de CA del cargador en la parte posterior del cargador.
3. Conecte el cable de alimentación a una toma de corriente adecuada.
4. Una vez que se haya realizado correctamente el encendido, cada indicador LED del estado de carga se enciende en color **verde** durante aproximadamente un segundo, y se mostrará **IMPRES 2 CHARGER**. Si los indicadores LED de estado del cargador no parpadean y no se muestra ningún mensaje, compruebe ambas conexiones del cable de alimentación.

5. Inserte un radio con la batería conectada o una batería independiente en una cavidad disponible.
- Nota:** Sujete el cuerpo del radio cuando lo inserte en el cargador o lo retire de él. Evite sacar la antena del radio.
6. Cuando el radio o la batería independiente estén correctamente ubicados en la cavidad, el estado de la carga se indica por medio del LED de estado de carga asociado. La pantalla asociada proporciona información adicional. En el caso de cargadores de una pantalla, en la pantalla se muestra el estado de carga solo de la cavidad n.º 1.
  7. La batería estará lista para usarse cuando el estado de carga esté de color **verde fijo**.
  8. Encienda el radio solo cuando el módulo de comunicaciones del cargador esté desconectado de una computadora. De lo contrario, APAGUE el dispositivo o radio.

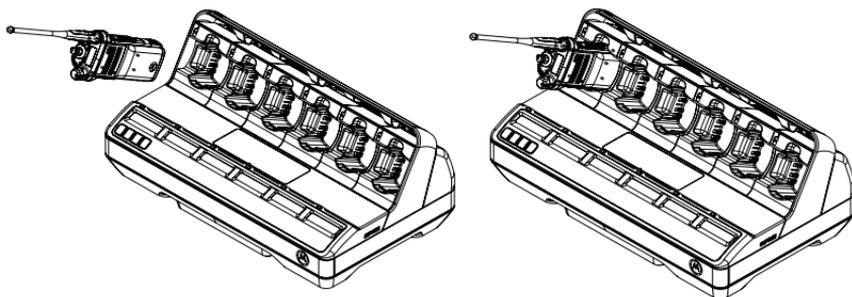

**Figura 2:** Carga de una batería conectada a un radio

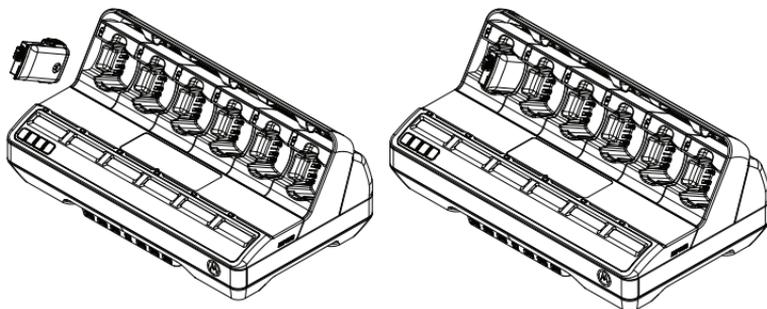

**Figura 3:** Carga de una batería independiente

## Carga de accesorios USB

Algunos módulos de comunicaciones del cargador IMPRES 2 para varias unidades proporcionan tomas USB tipo A para la carga de accesorios USB. Los accesorios USB se cargan mejor a temperatura ambiente.

1. Coloque el cargador adaptable IMPRES 2 en una superficie plana.
2. Inserte con firmeza el cable de alimentación en la toma de corriente del cargador de CA en la parte posterior del cargador.
3. Conecte el cable de alimentación a una toma de corriente adecuada.
4. Una vez que el encendido se realice correctamente, cada LED de estado de las cavidades se enciende en color **verde** durante un segundo, y se mostrará `IMPRES 2 CHARGER`. Si los LED de estado no parpadean y si no se muestra ningún mensaje, compruebe las conexiones del cable de alimentación.
5. Un accesorio USB puede tener un receptáculo micro-AB para realizar la carga. Utilice un cable USB estándar de 1 metro o uno más corto con un conector de tipo A en un extremo y un conector macho compatible con accesorios en el otro extremo (generalmente tipo micro-B o micro-AB).
6. Oriente el conector de tipo A del cable USB para alinearlos correctamente con un puerto tipo A en el módulo de comunicaciones. Inserte el conector en el puerto.
7. Oriente el conector de tipo micro-B del cable USB para alinearlos correctamente con el receptáculo tipo micro-AB en el accesorio USB. Inserte el conector en el receptáculo.
8. Cuando las conexiones USB se hayan establecido correctamente, el estado de la carga se indica mediante el accesorio USB. Consulte la Guía del usuario de accesorios USB para obtener más información.



## Indicaciones de carga

**Tabla 6:** Indicaciones de carga de una batería IMPRES o IMPRES 2: no se requiere calibración

Estado	Pantalla de la cavidad	Indicador LED
El cargador se enciende	IMPRES 2 CHARGER	Verde durante aproximadamente un segundo 
Batería detectada	IMPRES 2 BATTERY O IMPRES BATTERY	Rojo fijo 
Carga rápida	RAPID CHARGE XXXX0mAh yy%Pt1	Rojo fijo 
Carga en un 90 % o más	TRICKLE CHARGE xxxx0mAh yy%Pt1	Verde intermitente 
Carga en un 95 % o más	CHARGE COMPLETE xxxx0mAh yy%Pt1	Verde fijo 
Error	ADVERTENCIA: NOT CHARGEABLE REMOVE & REINSERT	Rojo intermitente 
En espera <ul style="list-style-type: none"> <li>• La batería requiere una carga rápida.</li> <li>• Es posible que la batería esté demasiado caliente, demasiado fría o que tenga bajo voltaje.</li> <li>• El cargador está demasiado caliente.</li> </ul>	ADVERTENCIA: HOT BATTERY WAITING TO CHARGE O COLD BATTERY WAITING TO CHARGE O VERY LOW BATTERY WAITING TO CHARGE O HOT CHARGER WAITING TO CHARGE	Ámbar intermitente 

### Nota:

- El mensaje **Hot Charger** se presentó en el software V1.05.
- Las indicaciones del porcentaje del estado de carga, con respecto a capacidad potencial frente a capacidad nominal, se presentaron en el software V1.11.01.

**Tabla 7:** Indicaciones de carga de la calibración de baterías IMPRES o IMPRES 2: calibración activada

Estado	Pantalla de la cavidad	Indicador LED
El cargador se enciende	IMPRES 2 CHARGER	Verde durante aproximadamente un segundo 
Batería detectada	IMPRES 2 BATTERY 0 IMPRES BATTERY	Ámbar fijo 
Descarga de la batería	CAL DISCHARGE xxxxx0mAh yy%Pt1	Ámbar fijo 
Carga rápida	CAL RAPID CHARGE xxxxx0mAh yy%Pt1	Rojo fijo 
Carga en un 90 % o más	CAL TRICKLE CHARGE xxxxx0mAh yy%Pt1	Verde intermitente 
Carga en un 95 % o más	<p>CHARGE COMPLETE xxxxx0mAh yy%Pt1</p>	<p>Calibración correcta de la batería: Verde fijo </p> <p>La calibración de la batería se realizó correctamente, pero es posible que esté llegando al final de su vida útil (ya no se puede utilizar la batería): Rojo/verde intermitentes </p>
	<p>REPLACE BATTERY EXPOSED OVERTEMP</p>	<p>La calibración de la batería se realizó correctamente, pero la batería se expuso a una temperatura excesiva acumulativa (se recomienda retirarla de la flota): Rojo/verde intermitentes NOTA: Solo se aplica a la batería APX NEXT XN </p>
Error	ADVERTENCIA: NOT CHARGEABLE REMOVE & REINSERT	Rojo intermitente 

**Tabla 7:** Indicaciones de carga de la calibración de baterías IMPRES o IMPRES 2: calibración activada (continuación)

Estado	Pantalla de la cavidad	Indicador LED
<p>En espera</p> <ul style="list-style-type: none"> <li>• La batería requiere una carga rápida.</li> <li>• Es posible que la batería esté demasiado caliente, demasiado fría o que tenga bajo voltaje.</li> <li>• El cargador está demasiado caliente.</li> </ul>	<p>ADVERTENCIA:  HOT BATTERY  WAITING TO CAL  ○  COLD BATTERY  WAITING TO CAL  ○  VERY LOW BATTERY  WAITING TO CHARGE  ○  HOT CHARGER  WAITING TO CAL</p>	<p>Ámbar intermitente</p> 

**Tabla 8:** Indicaciones de carga de la calibración de baterías IMPRES o IMPRES 2: calibración inicialmente desactivada y luego activada

Estado	Pantalla del cargador	Indicador LED
El cargador se enciende	IMPRES 2 CHARGER	Verde durante aproximadamente un segundo 
Batería detectada	IMPRES 2 BATTERY o IMPRES BATTERY	Es necesario calibrar la batería, pero la calibración está desactivada en el cargador: Ámbar/verde intermitentes durante cuatro segundos 
Solicitud de calibración de la batería IMPRES • La calibración está desactivada en el cargador. • La batería se está cargando.	ADVERTENCIA: ENABLE BATTERY CALIBRATION?  • Presione OK para activar la calibración • Ignorar para carga normal (mensaje eliminado después de 1 minuto)	Rojo fijo 
Descarga de la batería • Se seleccionó OK.	CAL DISCHARGE xxxx@mAh yy%P t1	Ámbar fijo 
Carga rápida	CAL RAPID CHARGE xxxx@mAh yy%P t1	Rojo fijo 
Carga en un 90 % o más	CAL TRICKLE CHARGE xxxx@mAh yy%P t1	Verde intermitente 

**Tabla 8:** Indicaciones de carga de la calibración de baterías IMPRES o IMPRES 2: calibración inicialmente desactivada y luego activada (continuación)

Estado	Pantalla del cargador	Indicador LED
Carga en un 95 % o más	CHARGE COMPLETE xxxxx@mAh yyyzP t1	Calibración correcta de la batería: Verde fijo   La calibración de la batería se realizó correctamente, pero es posible que esté llegando al final de su vida útil (ya no se puede utilizar la batería): Rojo/verde intermitentes 
	REPLACE BATTERY EXPOSED OVERTEMP	La calibración de la batería se realizó correctamente, pero la batería se expuso a una temperatura excesiva acumulativa (se recomienda retirarla de la flota): Rojo/verde intermitentes NOTA: Solo se aplica a la batería APX NEXT XN 
Error	ADVERTENCIA: NOT CHARGEABLE REMOVE& REINSERT	Rojo intermitente 
En espera <ul style="list-style-type: none"> <li>• La batería requiere una carga rápida.</li> <li>• Es posible que la batería esté demasiado caliente, demasiado fría o que tenga bajo voltaje.</li> <li>• El cargador está demasiado caliente.</li> </ul>	ADVERTENCIA: HOT BATTERY WAITING TO CAL O COLD BATTERY WAITING TO CAL O VERY LOW BATTERY WAITING TO CHARGE O HOT CHARGER WAITING TO CAL	Ámbar intermitente 

**Tabla 9:** Indicaciones de carga de una batería IMPRES o IMPRES 2: la calibración es necesaria, pero no está activada

Estado	Pantalla del cargador	Indicador LED
El cargador se enciende	IMPRES 2 CHARGER	Verde durante aproximadamente un segundo 
Batería detectada	IMPRES 2 BATTERY o IMPRES BATTERY	Es necesario calibrar la batería, pero la calibración está desactivada en el cargador: Ámbar/verde intermitentes durante cuatro segundos 
Solicitud de calibración de la batería IMPRES • La calibración está desactivada en el cargador. • La batería se está cargando.	ADVERTENCIA: ENABLE BATTERY CALIBRATION?  • Presione Aceptar para activar la calibración. • Ignore para carga normal (mensaje eliminado después de 1 minuto).	Rojo fijo 
Carga rápida • Solicitud de tiempo de espera agotado de calibración.	RAPID CHARGE xxxxx@mAh yyy%P t1	Rojo fijo 
Carga en un 90 % o más	TRICKLE CHARGE xxxxx@mAh yyy%P t1	Verde intermitente 
Carga en un 95 % o más	CHARGE COMPLETE xxxxx@mAh yyy%P t1	Ámbar/verde alternados 
Error	ADVERTENCIA: NOT CHARGEABLE REMOVE& REINSERT	Rojo intermitente 
En espera • La batería requiere una carga rápida. • Es posible que la batería esté demasiado caliente, demasiado fría o que tenga bajo voltaje. • El cargador está demasiado caliente.	ADVERTENCIA: HOT BATTERY WAITING TO CHARGE o COLD BATTERY WAITING TO CHARGE o VERY LOW BATTERY WAITING TO CHARGE o HOT CHARGER WAITING TO CHARGE	Ámbar intermitente 

Español (Latinoamérica)

**Tabla 10:** Indicaciones de carga de una batería IMPRES o IMPRES 2 con carga completa: la calibración es necesaria, pero no está activada

Estado	Pantalla del cargador	Indicador LED
El cargador se enciende	IMPRES 2 CHARGER	Verde durante aproximadamente un segundo 
Batería detectada	IMPRES 2 BATTERY o IMPRES BATTERY	La batería requiere calibración, pero alcanzó el estado de carga completa dentro de los últimos 30 minutos, aunque la calibración estaba desactivada en el cargador: Ámbar/verde alternados 
Error	ADVERTENCIA: NOT CHARGEABLE REMOVE& REINSERT	Rojo intermitente 
<p>En espera</p> <ul style="list-style-type: none"> <li>• La batería requiere una carga rápida.</li> <li>• Es posible que la batería esté demasiado caliente, demasiado fría o que tenga bajo voltaje.</li> <li>• El cargador está demasiado caliente.</li> </ul>	<p>ADVERTENCIA:</p> <p>HOT BATTERY WAITING TO CHARGE o COLD BATTERY WAITING TO CHARGE o VERY LOW BATTERY WAITING TO CHARGE o HOT CHARGER WAITING TO CHARGE</p>	<p>Ámbar intermitente</p> 

## Otras baterías de Motorola Solutions

**Tabla 11:** Indicaciones de carga para otras baterías de Motorola Solutions

Estado	Pantalla del cargador	Indicador LED
El cargador se enciende	IMPRES 2 CHARGER	Verde durante aproximadamente un segundo 
Batería detectada	MOTOROLA SOLUTIONS BATTERY	Rojo fijo 
Carga rápida	RAPID CHARGE	Rojo fijo 
Carga en un 90 % o más	TRICKLE CHARGE	Verde intermitente 
Carga en un 95 % o más	CHARGE COMPLETE	Verde fijo 
Error	ADVERTENCIA: NOT CHARGEABLE REMOVE & REINSERT	Rojo intermitente 
En espera <ul style="list-style-type: none"> <li>• La batería requiere una carga rápida.</li> <li>• Es posible que la batería esté demasiado caliente, demasiado fría o que tenga bajo voltaje.</li> <li>• El cargador está demasiado caliente.</li> </ul>	ADVERTENCIA: HOT BATTERY WAITING TO CHARGE ○ COLD BATTERY WAITING TO CHARGE ○ VERY LOW BATTERY WAITING TO CHARGE ○ HOT CHARGER WAITING TO CHARGE	Ámbar intermitente 



## Batería desconocida

Es posible que el cargador no pueda detectar algunas baterías desconocidas. Las baterías desconocidas no declaran los parámetros de carga de un modo que pueda reconocer el cargador. Si se detecta una batería desconocida, el cargador indicará la carga como se muestra en la Tabla 12.

**Tabla 12:** Indicaciones de carga para las baterías desconocidas

Estado	Pantalla del cargador	Indicador LED
El cargador se enciende	IMPRES 2 CHARGER	Verde durante aproximadamente un segundo 
Batería detectada	UNKNOWN BATTERY	Rojo fijo 
Carga rápida	RAPID CHARGE	Rojo fijo 
Casi cargada • Capacidad de la batería desconocida	TRICKLE CHARGE	Verde intermitente 
Cargada • Capacidad de la batería desconocida	CHARGE COMPLETE	Verde fijo 
Error	ADVERTENCIA: HOT CHARGEABLE REMOVE & REINSERT	Rojo intermitente 
En espera • La batería requiere una carga rápida. • Es posible que la batería esté demasiado caliente, demasiado fría o que tenga bajo voltaje. • El cargador está demasiado caliente.	ADVERTENCIA: HOT BATTERY WAITING TO CHARGE O COLD BATTERY WAITING TO CHARGE O VERY LOW BATTERY WAITING TO CHARGE O HOT CHARGER WAITING TO CHARGE	Ámbar intermitente 

## Almacenamiento a largo plazo de las baterías IMPRES o IMPRES 2

Las baterías IMPRES o IMPRES 2 independientes originales de Motorola Solutions (de iones de litio o níquel) se pueden preparar para el almacenamiento a largo plazo, en una ubicación de almacenamiento adecuada, mediante el uso de un cargador IMPRES 2 para varias unidades. Otros tipos de batería arrojan errores. Si la batería IMPRES 2 cuenta con un modo de suspensión, el cargador pone la batería en suspensión cuando se completa la carga para el almacenamiento a largo plazo.

Prepare solamente las baterías IMPRES o IMPRES 2 para el almacenamiento a largo plazo. Retire la batería del radio antes de colocarla en el cargador.

NO almacene una batería independiente en el cargador. Cuando la preparación para el almacenamiento a largo plazo se haya completado, retire inmediatamente la batería independiente del cargador.

La selección del almacenamiento a largo plazo sustituye a la calibración o el reacondicionamiento. Es posible que las baterías de litio que se preparan para el almacenamiento a largo plazo no cumplan con las normativas para el envío a través de carga aérea.

**Tabla 13:** Indicaciones de almacenamiento a largo plazo de una batería IMPRES o IMPRES 2: a la batería se le debe realizar la calibración

Estado	Pantalla del cargador	Indicador LED
El cargador se enciende	IMPRES 2 CHARGER	Verde durante aproximadamente un segundo 
Batería detectada	IMPRES 2 BATTERY o IMPRES BATTERY	La batería requiere calibración: Ámbar/verde intermitentes durante cuatro segundos 
Descarga de la batería	STORAGE DISCHARGE xxxx% Rated Cap	Ámbar fijo 
Carga rápida	STORAGE CHARGE xxxx% Rated Cap	Rojo fijo 

**Tabla 13:** Indicaciones de almacenamiento a largo plazo de una batería IMPRES o IMPRES 2: a la batería se le debe realizar la calibración (continuación)

Estado	Pantalla del cargador	Indicador LED
Almacenamiento a largo plazo completo	LONGTERM STORAGE xxx% Rated Cap	Ámbar/verde alternados 
<b>Error</b> <ul style="list-style-type: none"> <li>La batería no logra establecer un contacto eléctrico correcto con el cargador.</li> <li>La batería no es una batería IMPRES o IMPRES 2.</li> <li>Una condición desconocida está impidiendo que la batería se descargue.</li> <li>La carga se completó antes de que se lograra el objetivo de almacenamiento a largo plazo.</li> <li>La cavidad del cargador es de un tipo especial.</li> </ul>	<b>ADVERTENCIA:</b> NOT CHARGEABLE REMOVE& REINSERT O WRONG BATT TYPE CANNOT LT STORE O CANNOT DISCHARGE FOR LT STORAGE O STORE INCOMPLETE Low Capacity:yy% O RADIO POCKET CANNOT LT STORE O CHARGING POCKET CANNOT LT STORE	Rojo intermitente 
<b>En espera</b> <ul style="list-style-type: none"> <li>La batería requiere una carga rápida.</li> <li>Es posible que la batería esté demasiado caliente, demasiado fría o que tenga bajo voltaje.</li> <li>El cargador está demasiado caliente.</li> </ul>	<b>ADVERTENCIA:</b> HOT BATTERY WAITING TO CHRGE O COLD BATTERY WAITING TO CHRGE O VERY LOW BATTERY WAITING TO CHRGE O HOT CHARGER WAITING TO CHRGE	Ámbar intermitente 

**Nota:**

- Los siguientes mensajes se presentaron en la versión de software V1.05:
  - Cannot Discharge, for LT Storage
  - Store Incomplete, Low Capacity:yy%
  - Hot Charger, Waiting to Chrge
- Los siguientes mensajes se presentaron en la versión de software V1.11.01:
  - Wrong Batt Type, Cannot LT Store
  - Radio Pocket, Cannot LT Store
  - Charging Pocket, Cannot LT Store

**Tabla 14:** Indicaciones para el almacenamiento a largo plazo de una batería IMPRES o IMPRES 2: batería calibrada; se debe cargar hasta la selección

Estado	Pantalla del cargador	Indicador LED
El cargador se enciende	IMPRES 2 CHARGER	Verde durante aproximadamente un segundo 
Batería detectada	IMPRES 2 BATTERY o IMPRES BATTERY	Rojo fijo 
Carga rápida	STORAGE CHARGE xxx% Rated Cap	Rojo fijo 
Almacenamiento a largo plazo completo	LONGTERM STORAGE xxx% Rated Cap	Verde fijo 
<p>Error</p> <ul style="list-style-type: none"> <li>La batería no logra establecer un contacto eléctrico correcto con el cargador.</li> <li>La batería no es una batería IMPRES o IMPRES 2.</li> <li>Una condición desconocida está impidiendo que la batería se descargue.</li> <li>La carga se completó antes de que se lograra el objetivo de almacenamiento a largo plazo.</li> <li>La cavidad del cargador es de un tipo especial.</li> </ul>	<p>ADVERTENCIA:</p> <p>NOT CHARGEABLE REMOVE&amp; REINSERT O WRONG BATT TYPE CANNOT LT STORE O CANNOT DISCHARGE FOR LT STORAGE O STORE INCOMPLETE Low Capacity:yy% O RADIO POCKET CANNOT LT STORE O CHARGING POCKET CANNOT LT STORE</p>	Rojo intermitente 
<p>En espera</p> <ul style="list-style-type: none"> <li>La batería requiere una carga rápida.</li> <li>Es posible que la batería esté demasiado caliente, demasiado fría o que tenga bajo voltaje.</li> <li>El cargador está demasiado caliente.</li> </ul>	<p>ADVERTENCIA:</p> <p>HOT BATTERY WAITING TO CHRG O COLD BATTERY WAITING TO CHRG O VERY LOW BATTERY WAITING TO CHRG O HOT CHARGER WAITING TO CHRG</p>	Ámbar intermitente 

**Tabla 15:** Indicaciones de almacenamiento a largo plazo de una batería IMPRES o IMPRES 2: batería calibrada; se debe descargar hasta la selección

Estado	Pantalla del cargador	Indicador LED
El cargador se enciende	IMPRES 2 CHARGER	Verde durante aproximadamente un segundo 
Batería detectada	IMPRES 2 BATTERY o IMPRES BATTERY	Ámbar fijo 
Descarga de la batería	STORAGE DISCHARGE xxx% Rated Cap	Ámbar fijo 
Almacenamiento a largo plazo completo	LONGTERM STORAGE xxx% Rated Cap	Verde fijo 
<p>Error</p> <ul style="list-style-type: none"> <li>• La batería no logra establecer un contacto eléctrico correcto con el cargador.</li> <li>• La batería no es una batería IMPRES o IMPRES 2.</li> <li>• Una condición desconocida está impidiendo que la batería se descargue.</li> <li>• La carga se completó antes de que se lograra el objetivo de almacenamiento a largo plazo.</li> <li>• La cavidad del cargador es de un tipo especial.</li> </ul>	<p>ADVERTENCIA:</p> <p>NOT CHARGEABLE REMOVE&amp; REINSERT O</p> <p>WRONG BATT TYPE CANNOT LT STORE O</p> <p>CANNOT DISCHARGE FOR LT STORAGE O</p> <p>STORE INCOMPLETE Low Capacity:yy% O</p> <p>RADIO POCKET CANNOT LT STORE O</p> <p>CHARGING POCKET CANNOT LT STORE</p>	<p>Rojo intermitente </p>
<p>En espera</p> <ul style="list-style-type: none"> <li>• La batería requiere una carga rápida.</li> <li>• Es posible que la batería esté demasiado caliente, demasiado fría o que tenga bajo voltaje.</li> <li>• El cargador está demasiado caliente.</li> </ul>	<p>ADVERTENCIA:</p> <p>HOT BATTERY WAITING TO CHRG O</p> <p>COLD BATTERY WAITING TO CHRG O</p> <p>VERY LOW BATTERY WAITING TO CHRG O</p> <p>HOT CHARGER WAITING TO CHRG</p>	<p>Ámbar intermitente </p>

## Preparación para el envío de una batería de iones de litio

Las baterías IMPRES o IMPRES 2, u otras baterías de iones de litio originales de Motorola Solutions, se pueden preparar para enviarse mediante cargas aéreas con el uso del cargador IMPRES 2 para varias unidades. Otros tipos de batería arrojan errores. Si la batería de iones de litio IMPRES 2 cuenta con un modo de suspensión, el cargador pone la batería en suspensión cuando se completa la carga de envío de baterías de iones de litio.

Prepare solamente las baterías de iones de litio independientes de Motorola Solutions para su envío. Retire la batería del radio antes de colocarla en el cargador.

NO almacene una batería independiente en el cargador. Cuando la preparación para el envío de baterías de litio se haya completado, retire inmediatamente la batería independiente del cargador.

La selección del envío de baterías de iones de litio sustituye a la calibración o el reacondicionamiento.

### Baterías IMPRES o IMPRES 2

**Tabla 16:** Indicaciones de estado de la preparación de una batería de iones de litio para su envío: a la batería IMPRES o IMPRES 2 se le debe realizar la calibración

Estado	Pantalla del cargador	Indicador LED
El cargador se enciende	IMPRES 2 CHARGER	Verde durante aproximadamente un segundo 
Batería detectada	IMPRES 2 BATTERY o IMPRES BATTERY	La batería requiere calibración: Ámbar/verde intermitentes durante cuatro segundos 
Descarga de la batería	SHIP LI DISCHRG xxx% Rated Cap	Ámbar fijo 
Carga rápida	SHIP LI CHARGE xxx% Rated Cap	Rojo fijo 
Envío completado de baterías de iones de litio	LI READY TO SHIP xxx% Rated Cap	Ámbar/verde alternados 

**Tabla 16:** Indicaciones de estado de la preparación de una batería de iones de litio para su envío: a la batería IMPRES o IMPRES 2 se le debe realizar la calibración (continuación)

Estado	Pantalla del cargador	Indicador LED
<p>Error</p> <ul style="list-style-type: none"> <li>• La batería no logra establecer un contacto eléctrico correcto con el cargador.</li> <li>• La batería es desconocida o de níquel.</li> <li>• Una condición desconocida está impidiendo que la batería se descargue.</li> <li>• La carga se completó antes de que se pudiera lograr el objetivo de envío de baterías de iones de litio.</li> <li>• La cavidad del cargador es de un tipo especial.</li> </ul>	<p>ADVERTENCIA: HOT CHARGEABLE REMOVED&amp; REINSERT O WRONG BATT TYPE CANNOT SHIP LI O CANNOT DISCHARGE FOR LI SHIPMENT O SHIP INCOMPLETE Low Capacity:yy% O RADIO POCKET CANNOT SHIP LI O CHARGING POCKET CANNOT SHIP LI</p>	<p>Rojo intermitente</p> 
<p>En espera</p> <ul style="list-style-type: none"> <li>• La batería requiere una carga rápida.</li> <li>• Es posible que la batería esté demasiado caliente, demasiado fría o que tenga bajo voltaje.</li> <li>• El cargador está demasiado caliente.</li> </ul>	<p>ADVERTENCIA: HOT BATTERY WAITING TO CHARGE O COLD BATTERY WAITING TO CHARGE O VERY LOW BATTERY WAITING TO CHARGE O HOT CHARGER WAITING TO CHARGE</p>	<p>Ámbar intermitente</p> 

**Nota:**

- Los siguientes mensajes se presentaron en la versión de software V1.05:
  - Ship LI Discharge, xxx% Rated Capacity
  - Ship LI Charge, xxx% Rated Capacity
  - LI Ready to Ship, xx% Rated Capacity
  - Cannot Discharge, for LI Shipment
  - Ship Incomplete, Low Capacity:yy%
- Los siguientes mensajes se presentaron en la versión de software V1.11.01:
  - Wrong Batt Type, Cannot Ship LI
  - Radio Pocket, Cannot Ship LI
  - Charging Pocket, Cannot Ship LI

**Tabla 17:** Indicaciones de estado de la preparación de una batería de iones de litio para su envío: batería IMPRES o IMPRES 2 calibrada; se debe cargar

Estado	Pantalla del cargador	Indicador LED
El cargador se enciende	IMPRES 2 CHARGER	Verde durante aproximadamente un segundo 
Batería detectada	IMPRES 2 BATTERY o IMPRES BATTERY	Rojo fijo 
Carga rápida	SHIP LI CHARGE xxx% Rated Cap	Rojo fijo 
Envío completado de baterías de iones de litio	LI READY TO SHIP xxx% Rated Cap	Verde fijo 
<p>Error</p> <ul style="list-style-type: none"> <li>La batería no logra establecer un contacto eléctrico correcto con el cargador.</li> <li>La batería es desconocida o de níquel.</li> <li>Una condición desconocida está impidiendo que la batería se descargue.</li> <li>La carga se completó antes de que se pudiera lograr el objetivo de envío de baterías de iones de litio.</li> <li>La cavidad del cargador es de un tipo especial.</li> </ul>	<p>ADVERTENCIA:</p> <p>NOT CHARGEABLE REMOVE&amp; REINSERT o WRONG BATT TYPE CANNOT SHIP LI o CANNOT DISCHARGE FOR LI SHIPMENT o SHIP INCOMPLETE Low Capacity:yy% o RADIO POCKET CANNOT SHIP LI o CHARGING POCKET CANNOT SHIP LI</p>	Rojo intermitente 
<p>En espera</p> <ul style="list-style-type: none"> <li>La batería requiere una carga rápida.</li> <li>Es posible que la batería esté demasiado caliente, demasiado fría o que tenga bajo voltaje.</li> <li>El cargador está demasiado caliente.</li> </ul>	<p>ADVERTENCIA:</p> <p>HOT BATTERY WAITING TO CHRGE o COLD BATTERY WAITING TO CHRGE o VERY LOW BATTERY WAITING TO CHRGE o HOT CHARGER WAITING TO CHRGE</p>	Ámbar intermitente 



**Tabla 18:** Indicaciones de estado de la preparación de una batería de iones de litio para su envío: batería IMPRES o IMPRES 2 calibrada; se debe descargar

Estado	Pantalla del cargador	Indicador LED
El cargador se enciende	IMPRES 2 CHARGER	Verde durante aproximadamente un segundo 
Batería detectada	IMPRES 2 BATTERY o IMPRES BATTERY	Ámbar fijo 
Descarga de la batería	SHIP LI DISCHARGE xxx% Rated Cap	Ámbar fijo 
Envío completado de baterías de iones de litio	LI READY TO SHIP xxx% Rated Cap	Verde fijo 
<p>Error</p> <ul style="list-style-type: none"> <li>La batería no logra establecer un contacto eléctrico correcto con el cargador.</li> <li>La batería es desconocida o de níquel.</li> <li>Una condición desconocida está impidiendo que la batería se descargue.</li> <li>La carga se completó antes de que se pudiera lograr el objetivo de envío de baterías de iones de litio.</li> <li>La cavidad del cargador es de un tipo especial.</li> </ul>	<p>ADVERTENCIA:</p> <p>HOT CHARGEABLE REMOVE&amp; REINSERT o WRONG BATT TYPE CANNOT SHIP LI o CANNOT DISCHARGE FOR LI SHIPMENT o SHIP INCOMPLETE Low Capacity:yy% o RADIO POCKET CANNOT SHIP LI o CHARGING POCKET CANNOT SHIP LI</p>	<p>Rojo intermitente </p>
<p>En espera</p> <ul style="list-style-type: none"> <li>La batería requiere una carga rápida.</li> <li>Es posible que la batería esté demasiado caliente, demasiado fría o que tenga bajo voltaje.</li> <li>El cargador está demasiado caliente.</li> </ul>	<p>ADVERTENCIA:</p> <p>HOT BATTERY WAITING TO CHARGE o COLD BATTERY WAITING TO CHARGE o VERY LOW BATTERY WAITING TO CHARGE o HOT CHARGER WAITING TO CHARGE</p>	<p>Ámbar intermitente </p>

## Otras baterías de Motorola Solutions

**Tabla 19:** Indicaciones de estado de la preparación de una batería de iones de litio para su envío: otra batería de Motorola Solutions

Estado	Pantalla del cargador	Indicador LED
El cargador se enciende	IMPRES 2 CHARGER	Verde durante aproximadamente un segundo 
Batería detectada	MOTOROLA SOLUTNS BATTERY	Ámbar fijo 
Descarga de la batería	SHIP LI DISCHRG xxx% Rated Cap	Ámbar fijo 
Carga rápida	SHIP LI CHARGE xxx% Rated Cap	Rojo fijo 
Envío completado de baterías de iones de litio	LI READY TO SHIP xxx% Rated Cap	Verde fijo 
<b>Error</b> <ul style="list-style-type: none"> <li>La batería no logra establecer un contacto eléctrico correcto con el cargador.</li> <li>La batería es desconocida o de níquel.</li> <li>Una condición desconocida está impidiendo que la batería se descargue.</li> <li>La carga se completó antes de que se pudiera lograr el objetivo de envío de baterías de iones de litio.</li> <li>La cavidad del cargador es de un tipo especial.</li> </ul>	<b>ADVERTENCIA:</b> NOT CHARGEABLE REMOVE& REINSERT O WRONG BATT TYPE CANNOT SHIP LI O CANNOT DISCHARGE FOR LI SHIPMENT O SHIP INCOMPLETE Low Capacity:yy% O RADIO POCKET CANNOT SHIP LI O CHARGING POCKET CANNOT SHIP LI	Rojo intermitente 
<b>En espera</b> <ul style="list-style-type: none"> <li>La batería requiere una carga rápida.</li> <li>Es posible que la batería esté demasiado caliente, demasiado fría o que tenga bajo voltaje.</li> <li>El cargador está demasiado caliente.</li> </ul>	<b>ADVERTENCIA:</b> HOT BATTERY WAITING TO CHRGE O COLD BATTERY WAITING TO CHRGE O VERY LOW BATTERY WAITING TO CHRGE O HOT CHARGER WAITING TO CHRGE	Ámbar intermitente 

## Menú de configuración del cargador



Vacíe todas las cavidades del cargador antes de ingresar a la configuración del cargador.

El teclado del cargador se encuentra debajo de la pantalla de la cavidad n.º 1.

Para ingresar a la configuración del cargador, mantenga presionados simultáneamente los botones de flecha izquierda y derecha durante más tiempo que la selección del tiempo de entrada (3 segundos, de manera predeterminada).



**Figura 4:** Botones de la pantalla de menú para ingresar en el modo de configuración

### Menú principal

Después de ingresar a la configuración del cargador, aparecerá el siguiente mensaje en la pantalla:

```
Press OK to entr  
SETUP MENU
```

Si presiona OK, aparecerá el menú de configuración del cargador disponible.

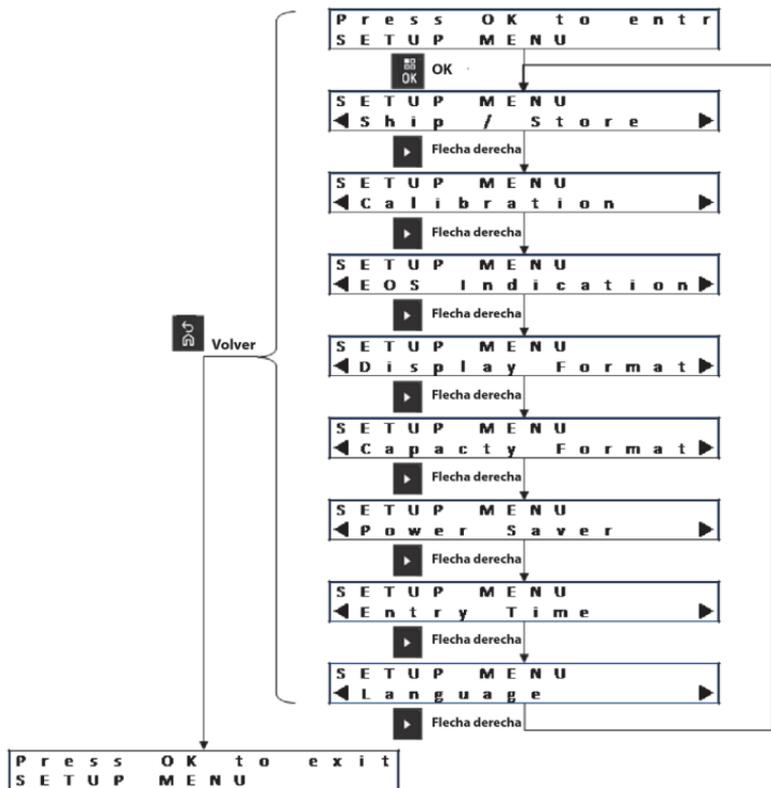

**Figura 5:** Menú de configuración del cargador

## Selección del menú de configuración del cargador

En cada selección del menú de configuración, realice lo siguiente:

- Para desplazarse por las selecciones del menú, presione la flecha derecha.
- Para desplazarse por las selecciones del menú en el orden inverso, presione la flecha izquierda.
- Para acceder al menú seleccionado o seleccionar la opción deseada, presione OK.

**Nota:** La marca de verificación identifica la opción seleccionada actualmente.

Se presentó en la V1.11.01. Presione OK para ver la siguiente cavidad en la pantalla de la cavidad n.º 1.

- Para salir del menú seleccionado, presione Atrás y luego presione OK para confirmar la salida.

Si no se presiona ningún botón del teclado durante 10 minutos, el cargador saldrá de la configuración del cargador y volverá a la pantalla normal de mensajes.

Las selecciones de configuración del cargador se almacenan en la memoria no volátil. No se ven afectadas por los ciclos de carga del cargador.

## Menú de envío o almacenamiento

Hay cuatro opciones de envío o almacenamiento:

- Desactivado
- Envío de baterías de iones de litio
- Almacenamiento a largo plazo
- Almacenamiento a largo plazo con una capacidad nominal de un 75 %

Las selecciones envío de baterías de iones de litio, almacenamiento a largo plazo y almacenamiento a largo plazo con una capacidad nominal de un 75 % tienen precedencia sobre la configuración de calibración.



Figura 6: Menú de envío/almacenamiento

## Envío de baterías de iones de litio

La opción Envío de baterías de iones de litio configura el estado de carga de una batería de iones de litio de Motorola Solutions a un valor bajo permitido para el envío masivo: aproximadamente un 25 % de la capacidad nominal.

Algunas baterías de Motorola Solutions pueden descargarse completamente antes de cargar hasta el límite de envío de baterías de iones de litio. Este tipo de baterías incluye baterías IMPRES o IMPRES 2 que nunca se han calibrado o que requieren una nueva calibración y otras baterías originales de Motorola Solutions que no sean IMPRES 2 o IMPRES.

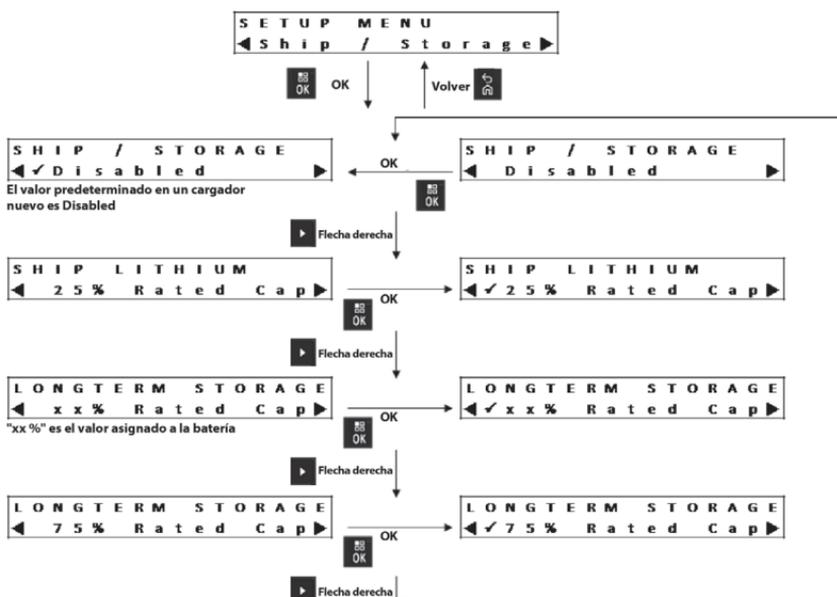
La opción de envío de baterías de iones de litio se aplica solamente a baterías de iones de litio originales de Motorola Solutions (IMPRES, IMPRES 2 u otras baterías de iones de litio de Motorola Solutions). Otras baterías (como baterías desconocidas o baterías de níquel o pequeñas de Motorola Solutions) arrojan errores.

## Almacenamiento a largo plazo

La opción de almacenamiento a largo plazo configura las baterías IMPRES o IMPRES 2 en un estado de carga adecuado para el almacenamiento de la batería durante un largo período. Por lo general, el estado de carga de almacenamiento de preferencia es significativamente menor que el de carga completa. La selección de  $xx\%$  es un valor programado en la batería IMPRES o IMPRES 2, o, de forma predeterminada, el 50 % de la capacidad nominal. Por ejemplo, la opción de almacenamiento a largo plazo con una capacidad nominal de un 75 % está disponible para situaciones que requieren que la batería almacenada tenga un estado de carga superior, con lo que se minimiza el tiempo de carga completa si la batería debe asignarse rápidamente o si se debe habilitar el almacenamiento para un período más largo.

Algunas baterías IMPRES o IMPRES 2 se pueden descargar completamente antes de cargarse hasta la selección de almacenamiento a largo plazo. Tales baterías son baterías IMPRES o IMPRES 2 que nunca se calibraron ni tampoco requirieron una nueva calibración.

El almacenamiento a largo plazo solo se aplica a las baterías IMPRES o IMPRES 2. Otras baterías (como baterías desconocidas o baterías pequeñas o que no sean IMPRES de Motorola Solutions) arrojan errores.

## Baterías IMPRES 2 con modo de suspensión

Algunas baterías IMPRES 2 tienen un modo de suspensión. El modo de suspensión se utiliza para extender el tiempo hasta la próxima carga de batería. Tras la finalización de la carga de envío de baterías de iones de litio o almacenamiento a largo plazo, el cargador pondrá estas baterías en suspensión.

Colocar una batería IMPRES 2 en suspensión en cualquier cargador anulará dicho modo. Si la batería se preparó para el envío de baterías de iones de litio, colocarla en un cargador configurado para dicha opción la devolverá a su estado de suspensión. Si la batería se preparó para el almacenamiento a largo plazo, colocarla en un cargador configurado para dicha opción la devolverá a su estado de suspensión.

## Menú de calibración

Las selecciones de configuración de calibración activan o desactivan la fase de descarga de la calibración o el reacondicionamiento. La fase de descarga es anterior a la carga completa necesaria para una calibración o un reacondicionamiento correctos. Esta función es útil cuando el cargador se asigna a una ubicación que requiere que la batería esté lista para usarse con la mayor rapidez posible. En estas situaciones, esperar que la batería se descargue puede ser un inconveniente.

Si a una batería IMPRES o IMPRES 2 se le debe realizar la calibración, y ya está descargada cuando se inserta en el cargador, el cargador usa el estado completo de la carga como una calibración de la batería.



Figura 7: Menú de calibración

## Menú de indicación LED del fin de la vida útil

Aunque la batería IMPRES o IMPRES 2 esté llegando al final de su vida útil, la capacidad de la batería puede ser más que suficiente para un uso más ligero. Como resultado, es posible que sea conveniente deshabilitar la indicación LED de fin de vida útil (**rojo/verde alternados**).

Para la batería APX NEXT XN, desactivar esta indicación desactiva también la indicación de batería expuesta a un exceso de temperatura acumulativa.

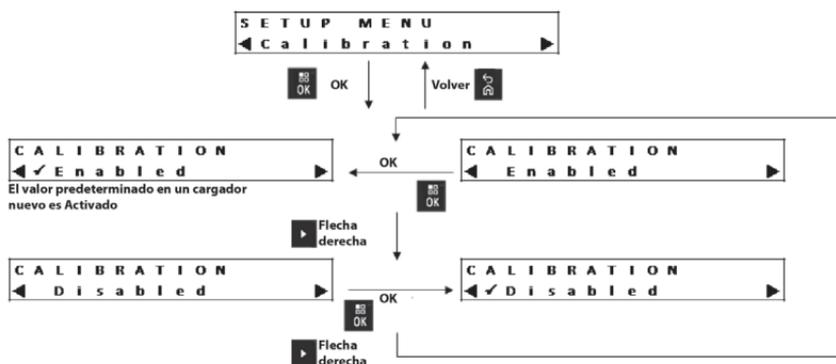

Figura 8: Menú de indicación LED del fin de la vida útil



## Menú de formato de pantalla

Hay cuatro opciones de formato de pantalla:

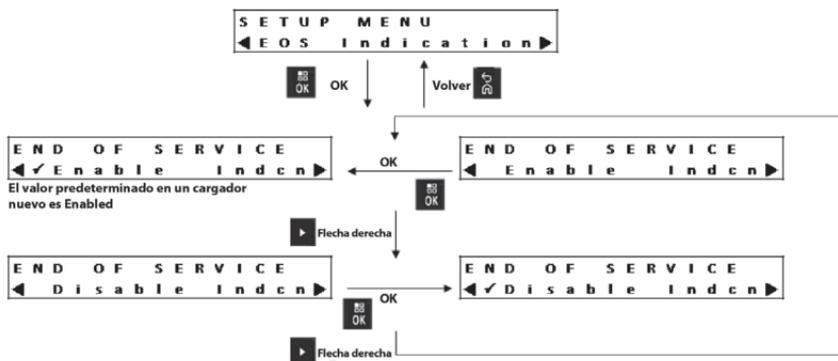
- Orientación normal (cargador sobre un escritorio).
- Orientación invertida (cargador montado en una pared).
- Solo mensajes de emergencia. No se muestran otros mensajes. Esto se aplica a las orientaciones normal e invertida. Los mensajes de advertencia se identifican de la Tabla 6 a la Tabla 12.
- La pantalla está apagada durante el funcionamiento normal. La pantalla siempre está activada en modo de configuración y analizador.



Figura 9: Menú de formato de pantalla

## Menú de formato de capacidad

La capacidad de la batería se muestra en uno de varios formatos disponibles. Si la capacidad de la batería se muestra como un porcentaje, este hace referencia a la capacidad potencial (carga completa) o a la capacidad nominal. Por lo general, en los radios IMPRES, se muestra el porcentaje de capacidad de la batería que hace referencia a la capacidad potencial.

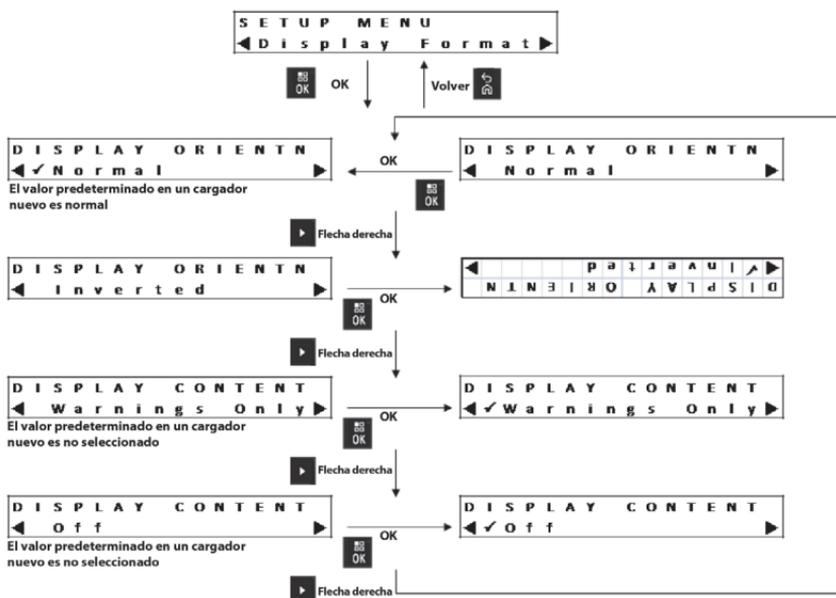

Figura 10: Menú de formato de capacidad

**Tabla 20:** Opciones de visualización de la capacidad de la batería

Representación	Descripción
xxx0mAh	Carga actual (estado de la carga) en miliamperios-hora.
yyy%	Carga presente en relación con la capacidad potencial o nominal, en porcentaje. Cuando se hace referencia a la capacidad potencial, el valor máximo es de 100 %. Cuando se hace referencia a la capacidad nominal, el valor máximo puede ser superior a un 100 %, especialmente en una batería nueva.
%BAR	El equivalente de yyy% representado en una barra de ocho segmentos.

## Menú de ahorro de energía

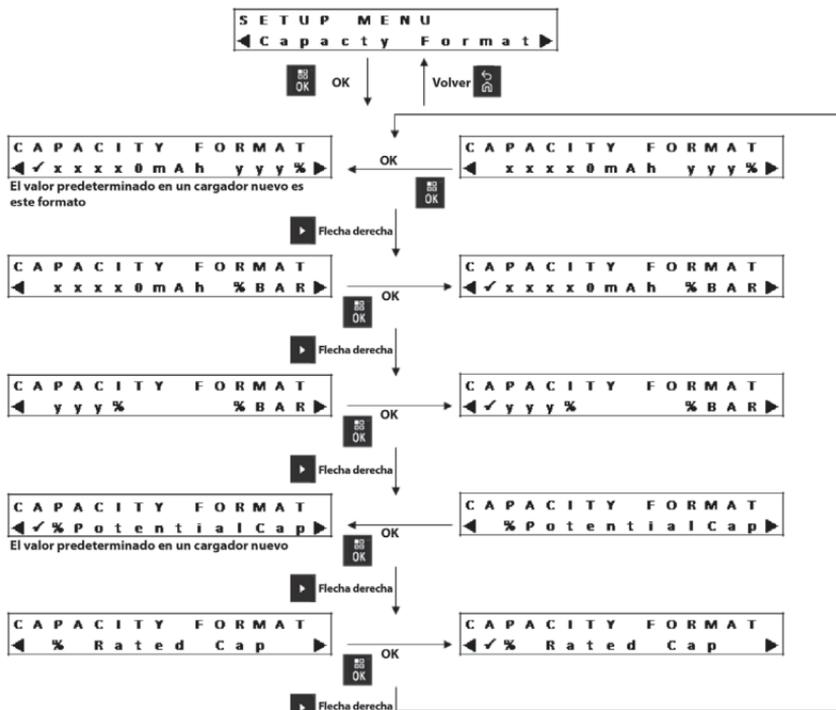
Para cumplir con ciertos límites gubernamentales de bajo consumo en modo de espera, el modo de ahorro de energía permite que el cargador apague todas las cavidades, excepto la cavidad n.º 1, cuando no haya actividad en las mismas durante un período. Estos son algunos ejemplos de actividad:

- Carga del radio o la batería.
- Calibración/reacondicionamiento de la batería.
- Preparación de baterías de iones de litio originales de Motorola Solutions para su envío.
- Preparación de las baterías IMPRES o IMPRES 2 para el almacenamiento a largo plazo.
- Modos de análisis y configuración del cargador.
- Reprogramación del cargador.
- Comunicación con el sistema IMPRES Battery Fleet Management.
- Cualquier indicación LED intermitente.

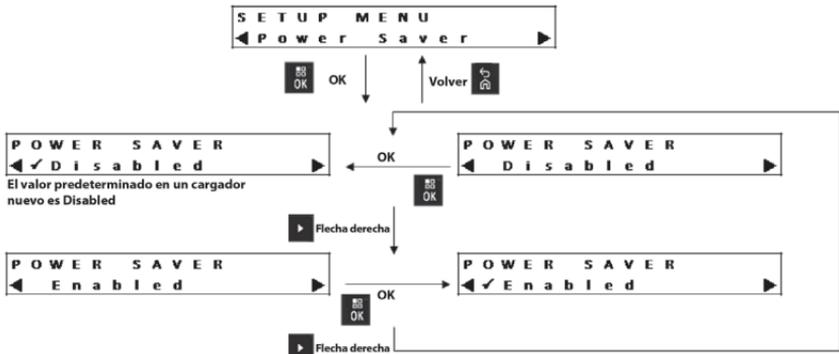

**Figura 11: Menú de ahorro de energía**

La cavidad n.º 1 permanece activada, pero puede estar en modo de suspensión. Para activar las otras cavidades, presione cualquier botón del teclado. Si las otras cavidades no se activan, no pueden responder al radio ni a la inserción o extracción de la batería.

## Menú de tiempo de entrada

El tiempo de entrada corresponde al tiempo que se mantiene presionado un botón para ingresar a los modos de configuración o analizador del cargador.



Figura 12: Menú de tiempo de entrada

## Menú de idioma

Actualmente, el cargador muestra los mensajes en un idioma: inglés norteamericano.

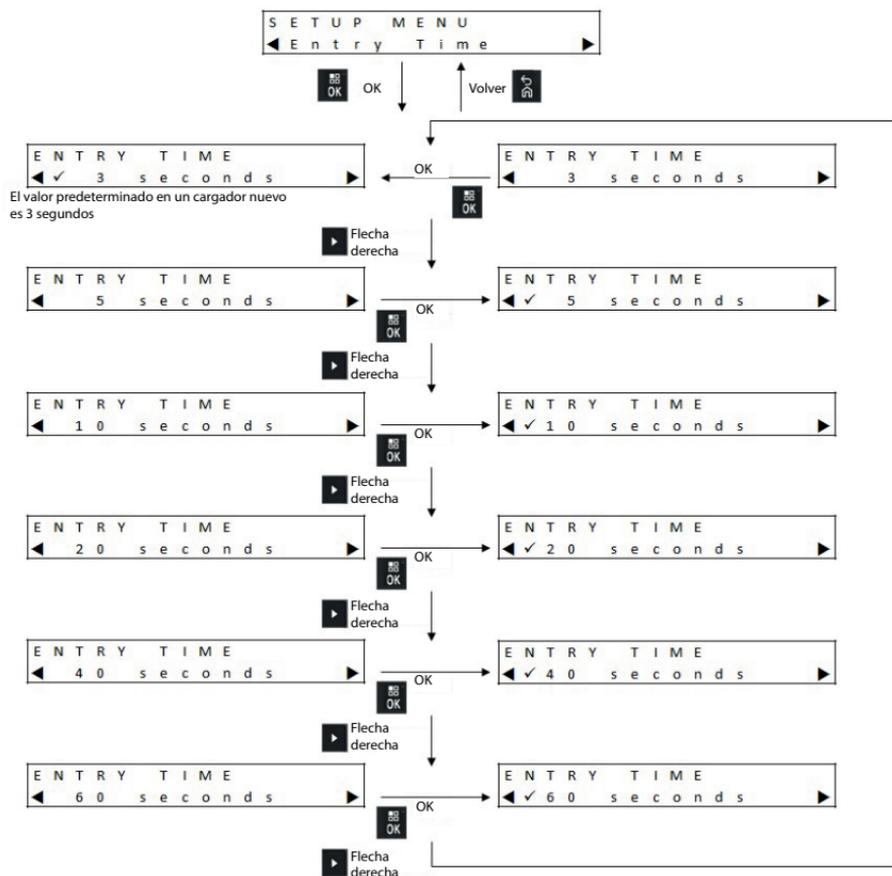
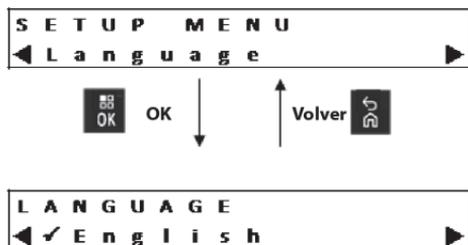

**Figura 13:** Menú de idioma

## Modo de analizador

El teclado del cargador se encuentra debajo de la pantalla de la cavidad n.º 1.

Para ingresar al modo de analizador, mantenga firmemente presionado el botón OK durante un tiempo mayor que el de la selección del tiempo de entrada (3 segundos, de manera predeterminada).



**Figura 14:** Botón de pantalla de menú para ingresar al modo de analizador

Después de ingresar al modo de analizador, el siguiente mensaje aparece en pantalla:

```
Press OK to entr  
ANALYZER MODE
```

Cuando presiona OK, se muestra información de la batería disponible.

## Modo de analizador de la versión V1.0

En la versión de software V1.0, el modo de analizador se limita a la cavidad n.º 1. La información de analizador con respecto a la cavidad n.º 1 y sus contenidos se presenta en la pantalla de la cavidad n.º 1. Si no se presiona ningún botón del teclado durante 10 minutos, el cargador saldrá del modo de analizador y volverá a la pantalla normal de mensajes.

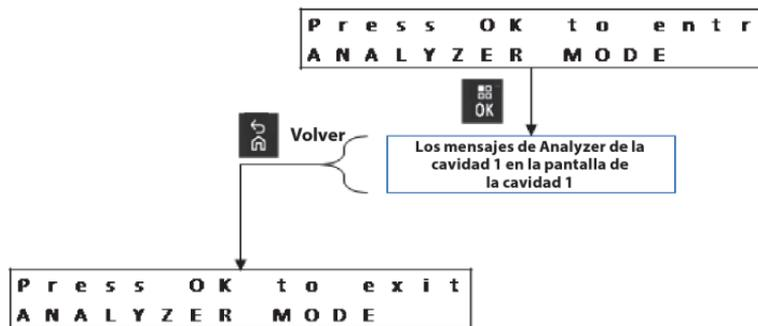

**Figura 15:** Menú del modo de analizador de la versión V1.0

## Modo de analizador de la versión V1.05

El modo de analizador mejoró con el lanzamiento del software versión V1.05. En el caso de los cargadores con una pantalla en cada cavidad, la información del analizador se muestra en la pantalla junto a su cavidad. Durante la navegación por la información de analizador en la cavidad n.º 1, las otras pantallas navegan por la información de analizador disponible para su cavidad adyacente.



Figura 16: Menú del modo de analizador de la versión V1.05

## Modo de analizador de la versión V1.11.01

El modo de analizador mejoró nuevamente con el lanzamiento del software versión V1.11.01. En el caso de los cargadores con una pantalla solo en la cavidad n.º 1, la pantalla del menú de la cavidad n.º 1 se puede utilizar para ver información de cualquier otra cavidad del cargador. La mejora de la versión V1.05 se mantiene.

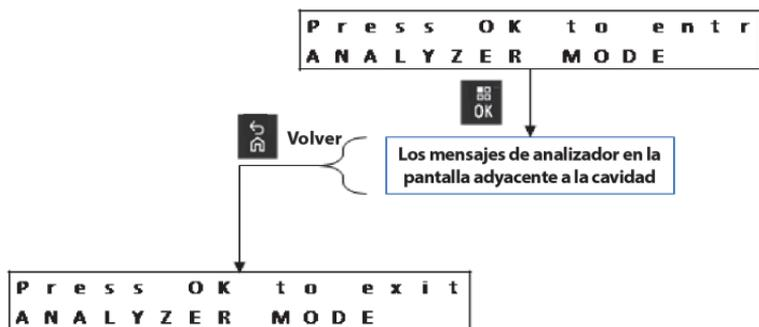

Figura 17: Menú del modo de analizador de la versión V1.11.01



## Cambio de las baterías en una cavidad

Si se retira la batería y después se inserta la misma batería o una diferente en la misma cavidad, el parámetro que se muestra para la segunda batería es el mismo que se mostraba para la primera.

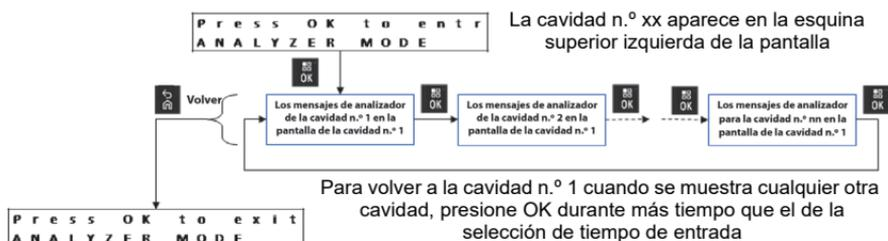
Por ejemplo, se muestra `Battery IMPRES Cycles` para una batería IMPRES o IMPRES 2. Esta batería se retira de la cavidad. Se inserta una batería IMPRES o IMPRES 2 diferente en la misma cavidad. El primer parámetro que se muestra para la segunda batería es `Battery IMPRES Cycles`.

Sin embargo, es posible que en la segunda batería no se muestre el parámetro de la primera. En este caso, el mensaje de identificación se muestra para la segunda batería.

# Batería IMPRES 2

## Pantalla adyacente a la cavidad

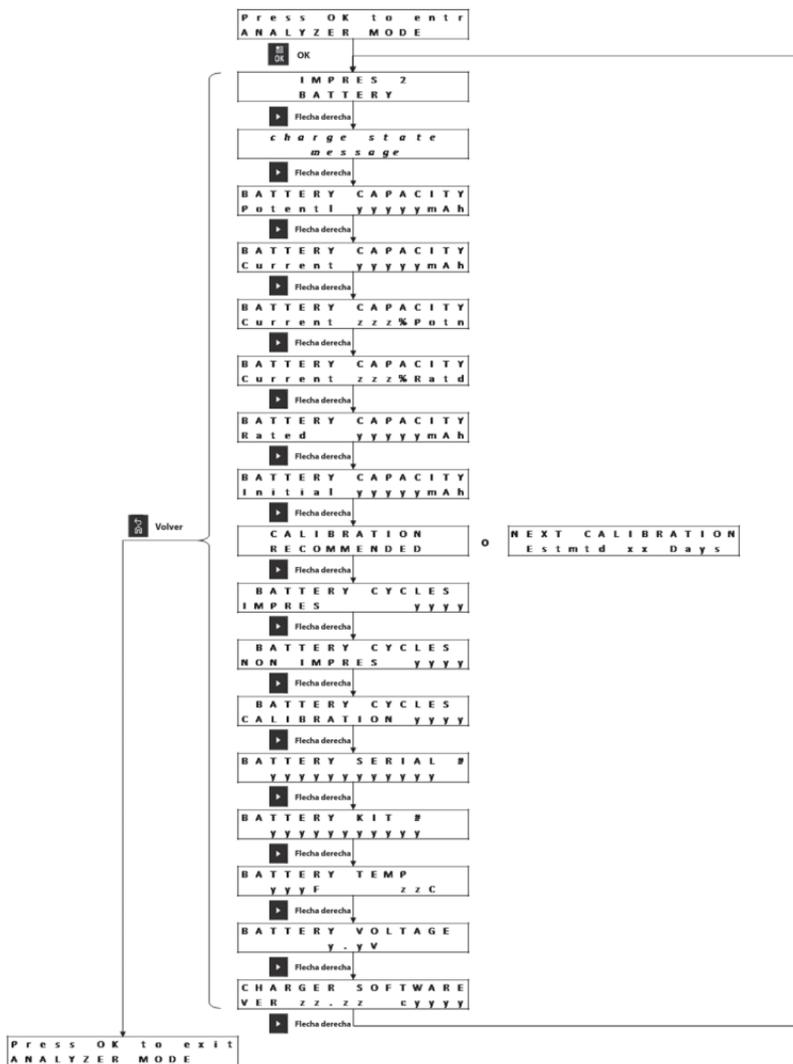

Español (Latinoamérica)

Figura 18: Menú del modo de analizador de la batería IMPRES 2 para la pantalla adyacente a la cavidad

## Cavidad n.º 1 que muestra otra cavidad

La cavidad n.º xx aparece en la esquina superior izquierda de la pantalla

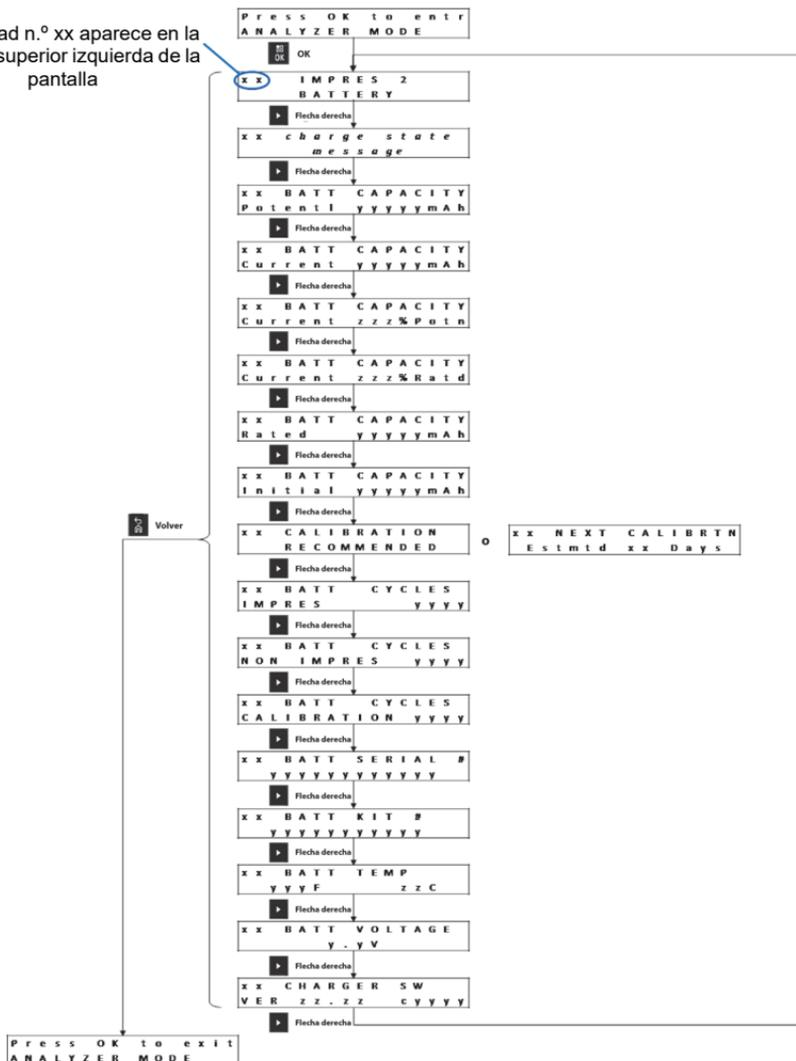

**Figura 19:** Menú del modo de analizador de la batería IMPRES 2 para otra cavidad (distinta de la cavidad n.º 1)

# Batería IMPRES

## Pantalla adyacente a la cavidad



Figura 20: Menú del modo de analizador de la batería IMPRES para la pantalla adyacente a la cavidad

## Cavidad n.º 1 que muestra otra cavidad

La cavidad n.º xx aparece en la esquina superior izquierda de la pantalla

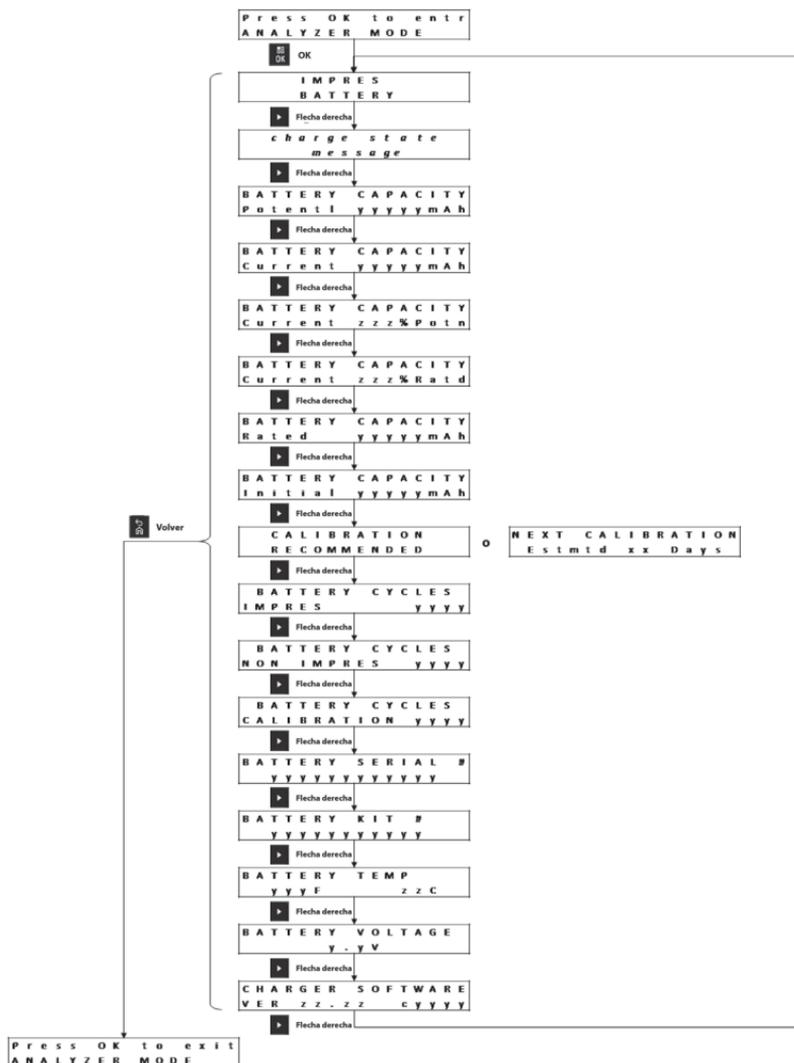
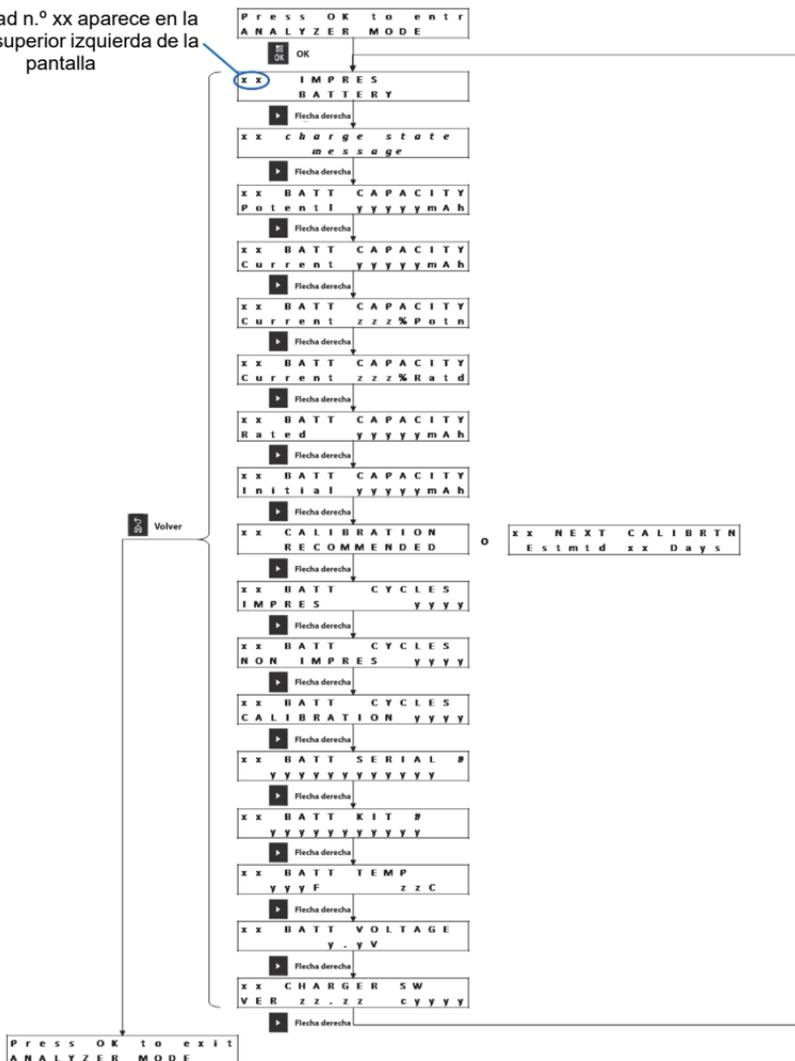

**Figura 21:** Menú del modo de analizador de la batería IMPRES para otra cavidad (distinta de la cavidad n.º 1)

# Otras baterías de Motorola Solutions

## Pantalla adyacente a la cavidad



Figura 22: Menú del modo de analizador de otra batería de Motorola Solutions para la pantalla adyacente a la cavidad

## Cavidad n.º 1 que muestra otra cavidad

La cavidad n.º xx aparece en la esquina superior izquierda de la pantalla

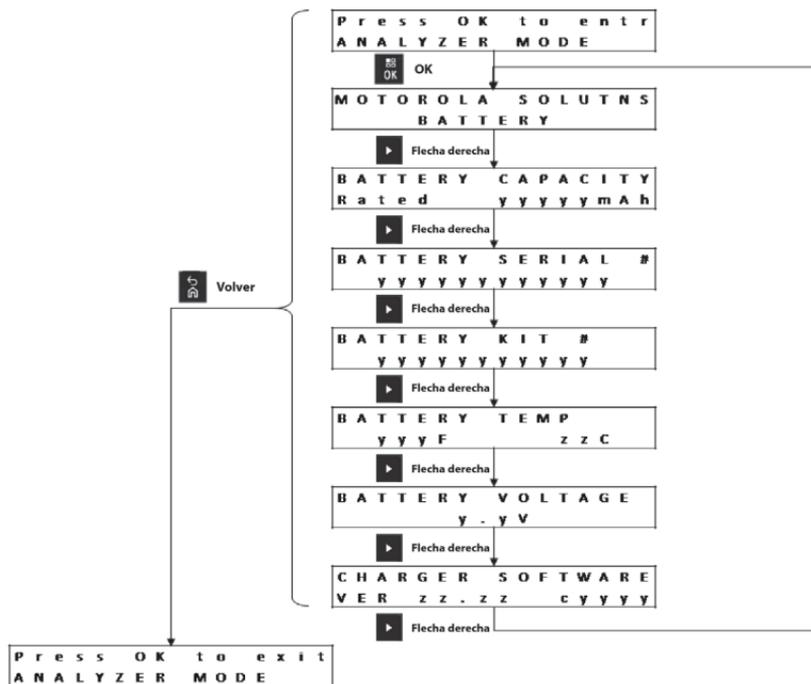
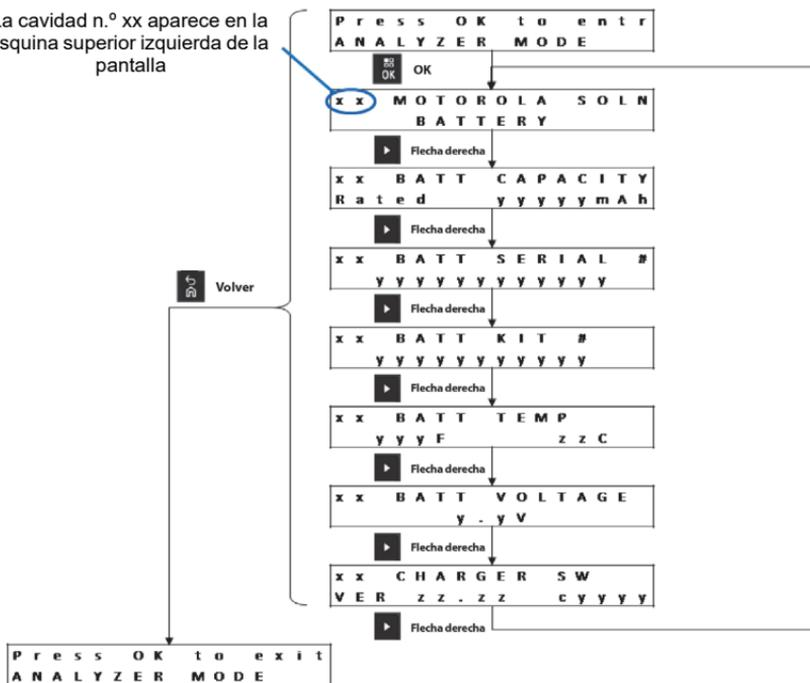

**Figura 23:** Menú del modo de analizador de otra batería de Motorola Solutions para otra cavidad (distinta de la cavidad n.º 1)

## Batería desconocida

### Pantalla adyacente a la cavidad



Figura 24: Menú del modo de analizador de una batería desconocida para la pantalla adyacente a la cavidad

### Cavidad n.º 1 que muestra otra cavidad

La cavidad n.º xx aparece en la esquina superior izquierda de la pantalla

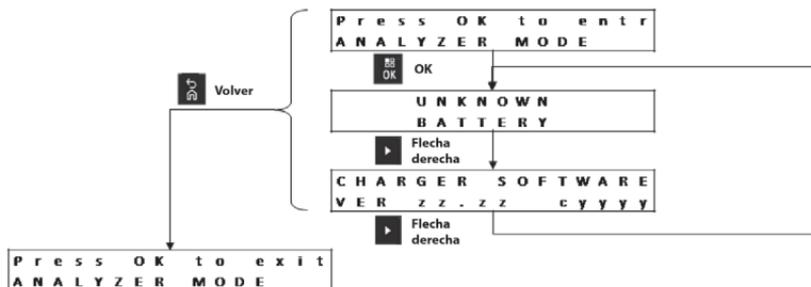

Figura 25: Menú del modo de analizador de una batería desconocida para otra cavidad (distinta de la cavidad n.º 1)



## Cavidad vacía

### Pantalla adyacente a la cavidad

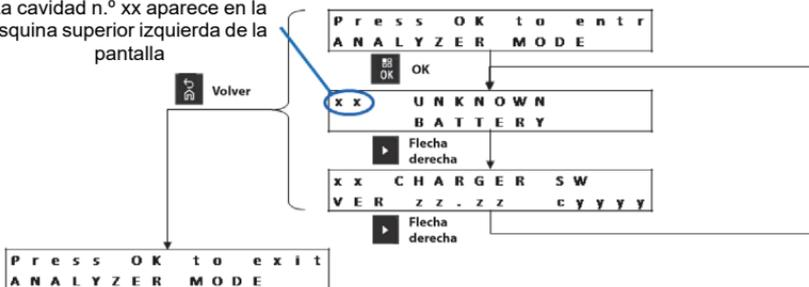
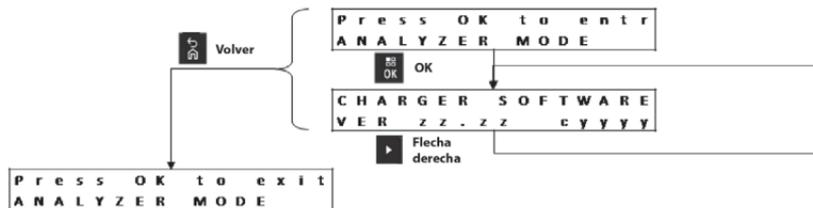

**Figura 26:** Menú del modo de analizador para una cavidad vacía adyacente a la pantalla

### Cavidad n.º 1 que muestra otra cavidad

La cavidad n.º xx aparece en la esquina superior izquierda de la pantalla

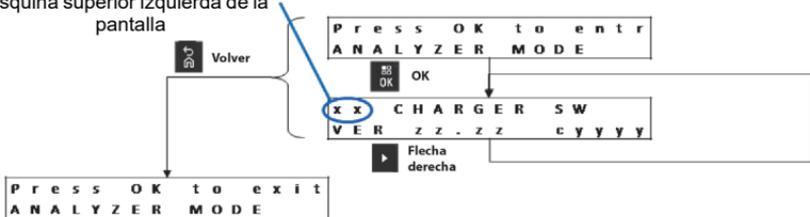

**Figura 27:** Menú del modo de analizador para una cavidad vacía (distinta de la cavidad n.º 1)

## Mensaje del estado del cargador

Algunas baterías IMPRES 2 tienen un modo de suspensión. Al final del estado Envío de baterías de iones de litio, xx% de almacenamiento a largo plazo o 75 % de almacenamiento a largo plazo, una batería con el modo de suspensión entra en suspensión. El mensaje de estado de carga del modo de analizador le permite comprobar el estado de carga de las baterías en suspensión.

**Tabla 21:** Envío de baterías de iones de litio activado y carga completa de envío de baterías de iones de litio

Pantalla adyacente a la cavidad	Cavidad n.º 1 que muestra otra cavidad
SHIP LI SLEEP xxx% Rated Cap	xx SHIP LI SLEEP xxx% Rated Cap

**Tabla 22:** Un xx % de almacenamiento a largo plazo activado y carga de un xx % de almacenamiento a largo plazo completada en la batería

Pantalla adyacente a la cavidad	Cavidad n.º 1 que muestra otra cavidad
STORAGE SLEEP xxx% Rated Cap	xx STORAGE SLEEP xxx% Rated Cap

Por ejemplo, el mensaje del estado de carga no se muestra si xx % de almacenamiento a largo plazo está activado y se completó la carga de un 75 % de almacenamiento a largo plazo de la batería en un cargador diferente.

## Reprogramación del cargador

La reprogramación del cargador requiere que se conecte el módulo de comunicaciones a una computadora mediante un cable USB estándar. Si utiliza el sistema IMPRES Battery Fleet Management para iniciar la reprogramación del cargador, se muestran los siguientes mensajes en el cargador.

Extraiga las baterías de las cavidades del cargador antes de la reprogramación:

```
REPROGRAMMING
REMOVE BATTERIES
```

Todas las cavidades del cargador están vacías:

```
REPROGRAMMING
WAITING FOR DATA
```

Se están descargando los datos de reprogramación:

```
REPROGRAMMING
Progress yyy%
```

En el caso de los cargadores con una pantalla asociada a cada cavidad, el valor del porcentaje es el porcentaje de datos descargados correctamente en la cavidad asociada a la pantalla. En el caso de los cargadores que tienen una sola pantalla (cavidad n.º 1), el valor del porcentaje corresponde al de los datos descargados correctamente en todas las cavidades.

Se produjo un error en la reprogramación de la cavidad indicada:

```
REPROGRAMMING  
POCKET#xx FAILED
```

La cavidad del cargador identificada inicia las operaciones normales con el software anterior.

La descarga de datos de reprogramación está completa. La carga está completando el proceso de reprogramación.

```
IMPRES 2  
CHARGER
```

El proceso de reprogramación se realizó correctamente.

```
REPROGRAMMING  
COMPLETE
```

El cargador inicia las operaciones normales con el software recién descargado. La configuración definida por el usuario se conserva después de que se completa la reprogramación del cargador.

# Solución de problemas del cargador

**Tabla 23:** Solución de problemas: carga normal

Problema	Qué se debe hacer
<p>El LED de la cavidad no se enciende de color verde durante aproximadamente 1 segundo cuando se activa el cargador.</p>	<p>Asegúrese de que el cable de alimentación esté bien enchufado al cargador y a una toma de alimentación de CA apropiada.</p> <p>Asegúrese de que la toma de corriente reciba energía.</p> <p>Inspeccione los fusibles y sustitúyalos si es necesario.</p>
<p>La batería o el radio están insertados en la cavidad, pero el LED de la cavidad permanece apagado y la batería no aparece identificada en la pantalla adyacente.</p>	<p>Si la cavidad no es la n.º 1 y el modo de ahorro de energía está activado, presione un botón del menú.</p> <p>Vea a continuación.</p>
<p>El LED de color rojo intermitente  y la pantalla (si está disponible) indican lo siguiente:</p> <p>NOT CHARGEABLE REMOVE &amp; REINSERT</p> <p>o una batería de Motorola Solutions se encuentra en la cavidad, pero la pantalla (si está disponible) indica lo siguiente:</p> <p>UNKNOWN BATTERY</p>	<p>Retire la batería o el radio de la cavidad.</p> <p>Compruebe si hay contaminación, corrosión o daño físico en los contactos eléctricos de la batería y la cavidad del cargador.</p> <p>Verifique que la batería sea una batería autorizada de Motorola Solutions. Es posible que otras baterías no se carguen.</p> <p>Limpie los contactos eléctricos de la batería con un paño seco.</p> <p>Desconecte la alimentación del cargador; a continuación, limpie los contactos eléctricos de la cavidad con un paño seco.</p> <p>Intente sustituir la batería. Si la falla desaparece, retire de servicio la batería.</p> <p>Si la falla persiste con la batería de repuesto, retire de servicio el cargador.</p>
<p>LED rojo/verde  alternados al final de la calibración.</p>	<p>Es posible que la batería IMPRES o IMPRES 2 esté llegando al final de su vida útil. La batería se puede utilizar; sin embargo, la capacidad disponible podría no ser la adecuada para un uso intenso durante un período prolongado.</p> <p>Solo se aplica a la batería APX NEXT XN: la batería se expuso a altas temperaturas durante más de 10 minutos. Se recomienda retirar la batería del servicio.</p>

**Tabla 23:** Solución de problemas: carga normal (continuación)

Problema	Qué se debe hacer
LED ámbar/ verde  verde alternados durante aproximadamente 4 segundos al insertar la batería en el cargador.	La batería IMPRES o IMPRES 2 requiere calibración o reacondicionamiento. En la siguiente oportunidad disponible, coloque la batería en un cargador IMPRES 2 que tenga la calibración activada y permita que el cargador complete la calibración (verde fijo).
En el modo de analizador, la cavidad n.º 1 puede mostrar otra cavidad.	El cargador no puede detectar la pantalla en al menos una de las cavidades.

**Tabla 24:** Solución de problemas:  
carga de almacenamiento a largo plazo

Problema	Qué se debe hacer
El LED de color rojo intermitente  y la pantalla (si está disponible) indican lo siguiente: WRONG BATT TYPE CANNOT LT STORE o CANNOT DISCHARGE CANNOT LT STORE	Retire la batería de la cavidad. Verifique que la batería NO esté conectada a un radio. Verifique que la batería sea IMPRES o IMPRES 2. Otras baterías presentarán problemas. Limpie los contactos eléctricos de la batería IMPRES o IMPRES 2 con un paño seco. Desconecte la alimentación del cargador; a continuación, limpie los contactos eléctricos de la cavidad con un paño seco. Pruebe sustituir la batería con otra batería IMPRES o IMPRES 2. Si la falla desaparece, retire de servicio la batería defectuosa IMPRES o IMPRES 2. Si la falla persiste con la batería IMPRES o IMPRES 2 de repuesto, retire de servicio el cargador.
El LED de color rojo intermitente  y la pantalla (si está disponible) indican lo siguiente: STORE INCOMPLETE Low Capacity:yy%	La capacidad potencial de la batería IMPRES o IMPRES 2 puede ser menor que la selección del almacenamiento a largo plazo. Es posible que la batería esté llegando al fin de su vida útil.

**Tabla 24:** Solución de problemas:  
carga de almacenamiento a largo plazo (continuación)

Problema	Qué se debe hacer
<p>El LED de color rojo intermitente y la pantalla (si está disponible) indican lo siguiente:</p> <p>RADIO POCKET CANNOT LT STORE</p> <p>o</p> <p>CHARGING POCKET CANNOT LT STORE</p>	<p>La cavidad del cargador no es la cavidad estándar para cargar una batería (mediante contactos eléctricos entre el cargador y la batería).</p> <ul style="list-style-type: none"> <li>• Una cavidad para radio es una cavidad especial en la cual la batería se conecta al radio, sin contactos externos en la batería, y la batería se carga mediante contactos eléctricos presentes en el radio.</li> <li>• Una cavidad de carga es una cavidad que utiliza energía del cargador para un propósito especial, como los puertos de carga USB.</li> </ul> <p>Cambie la batería a una cavidad estándar o reemplace la cavidad para radio o de carga con una cavidad estándar.</p>

**Tabla 25:** Solución de problemas:  
carga para envío de baterías de iones de litio

Problema	Qué se debe hacer
<p>El LED de color rojo intermitente y la pantalla (si está disponible) indican lo siguiente:</p> <p>WRONG BATT TYPE CANNOT SHIP LI</p>	<p>Retire la batería de la cavidad. Verifique que la batería NO esté conectada a un radio.</p> <p>Verifique que la batería sea IMPRES, IMPRES 2 u otra batería de iones de litio autorizada por Motorola Solutions. Otras baterías presentarán problemas.</p> <p>Limpie los contactos eléctricos de la batería IMPRES, IMPRES 2 u otra batería de iones de litio autorizada por Motorola Solutions con un paño seco.</p> <p>Desconecte la alimentación del cargador; a continuación, limpie los contactos eléctricos de la cavidad con un paño seco.</p> <p>Pruebe reemplazar la batería con otra batería IMPRES, IMPRES 2 u otra batería de iones de litio autorizada por Motorola Solutions. Si la falla ya no está presente, entonces retire de servicio la batería defectuosa IMPRES, IMPRES 2 u otra batería de iones de litio autorizada por Motorola Solutions.</p> <p>Si la falla persiste con el reemplazo de la batería IMPRES, IMPRES 2 u otra batería de iones de litio autorizada por Motorola Solutions, retire de servicio el cargador.</p>

**Tabla 25:** Solución de problemas:  
carga para envío de baterías de iones de litio (continuación)

Problema	Qué se debe hacer
<p>El LED de color rojo intermitente y la pantalla (si está disponible) indican lo siguiente:</p> <p>SHIP INCOMPLETE Low Capacity:yy%</p>	<p>La capacidad potencial de una batería de iones de litio original de Motorola Solutions debe ser menor que el límite de la opción envío de baterías de iones de litio. Es posible que la batería esté llegando al fin de su vida útil.</p>
<p>El LED de color rojo intermitente y la pantalla (si está disponible) indican lo siguiente:</p> <p>RADIO POCKET CANNOT LT STORE o CHARGING POCKET CANNOT SHIP LI</p>	<p>La cavidad del cargador no es la cavidad estándar para cargar una batería (mediante contactos eléctricos entre el cargador y la batería).</p> <ul style="list-style-type: none"> <li>• Una cavidad para radio es una cavidad especial en la cual la batería se conecta al radio, sin contactos externos en la batería, y la batería se carga mediante contactos eléctricos presentes en el radio.</li> <li>• Una cavidad de carga es una cavidad que utiliza energía del cargador para un propósito especial, como los puertos de carga USB.</li> </ul> <p>Cambie la batería a una cavidad estándar o reemplace la cavidad para radio o de carga con una cavidad estándar.</p>

## Sistema IMPRES Battery Fleet Management

El software IMPRES Battery Fleet Management recopila automáticamente datos importantes de las baterías IMPRES o IMPRES 2 insertadas en un cargador IMPRES. Entre los datos importantes, se incluyen los siguientes: antigüedad, capacidad, historial de carga y calibración/reacondicionamiento, fecha de fabricación y fecha de puesta en servicio de la batería. El software IMPRES Battery Fleet Management analiza los datos de la batería, comunica el estado de la batería y recomienda cuándo se debe reemplazar. Por lo tanto, puede determinar con rapidez y eficacia si se debe o no reasignar la batería a un usuario con menos exigencias, cuándo se debe comprar una nueva batería de reemplazo o cuándo buscar una batería faltante.

El sistema IMPRES Battery Fleet Management proporciona información muy importante sobre las baterías:

- Cuando las baterías están por debajo de una capacidad aceptable.
- Ayuda a garantizar que los usuarios tengan la capacidad suficiente para un turno de trabajo completo.
- Identifica las baterías de baja capacidad para que puedan retirarse de servicio.
- Elimina las interrupciones del trabajo y los tiempos de inactividad imprevistos.
- Evita los costos que supone deshacerse prematuramente de las baterías.
- Confirma que los cargadores se distribuyen y utilizan de manera óptima.

El software IMPRES Battery Fleet Management se puede ampliar de sistemas de red de un solo sitio a varios sitios, como se representa en la Figura 28. El sistema IMPRES Battery Fleet Management admite lo siguiente:

- Un servidor de administrador del sistema
- 19 clientes remotos
- 25 cargadores IMPRES o lectores de baterías IMPRES por cliente.
- 25.000 baterías IMPRES en la misma ubicación o en áreas geográficamente dispersas (la cantidad total de baterías para todo el sistema no puede superar las 25.000).





**Figura 28:** IMPRES Battery Fleet Management a través de cargadores de red

El sistema IMPRES Battery Fleet Management consta de tres componentes principales:

- Un software de aplicación.
- Una clave de licencia de software.
- Un cable USB para conectar el cargador IMPRES 2, el módulo de comunicaciones IMPRES 2, la unidad de interfaz del cargador (CIU) IMPRES o el lector de datos de la batería IMPRES a una computadora que aloja un cliente remoto.

Utiliza los informes existentes para personalizar otros nuevos y ver así la información más relevante para su empresa. Los datos se almacenan en su base de datos y pueden exportarse a un archivo de Excel™ o imprimirse. El software IMPRES Battery Fleet Management registra y organiza una serie de datos para que pueda realizar lo siguiente:

- Ver una captura del estado de toda la flota de baterías.
- Evaluar si las baterías cumplen con sus criterios de rendimiento.
- Determinar si las baterías se encuentran cerca del final de su vida útil.
- Decidir exactamente cuándo se deben comprar nuevas baterías.
- Obtener un informe de batería extraviada.
- Optimizar la utilización del cargador.
- Monitorear todos los dispositivos en el sistema.

Serial Number	Alias	Group	Radio Family	ID Number	Chemistry	Used	Rated Capacity	Potential Capacity	Date of First Use
5100000247478	Sam	Building 1	XTS 3000/3000/2000	HW906118	NaClE	No	1123	1195	8/1/2009
5100000189480	Matt	Security	APR	WNTN7975A	NaOH	No	2100	1480	5/21/2008
5100000189488	Inf-Inf	Security	APR	WNTN7976A	NaOH	Yes	2000	1400	2/14/2007
5100000282521	Phil	Administration	HT1G2/PRO Series	HW906246	NaClE	No	1350	1245	2/4/2009
510000031112	Pete	Building 1	XTS 3000/3000/2000	WNTN4407B	NaOH	Yes	1700	1360	8/14/2008
5100000249355	Steve	Building 1	XTS 2500, WTSMTJ/RJ 1550	WNTN7974A	Li-Ion	No	2000	1440	3/24/2009
5100000348611	Adam	None	Galve	HW906126	NaClE	No	2000	1460	9/5/2009
5100000348173	Mark	Building 2	XTS 2500, WTSMTJ/RJ 1550	WNTN7976A	Li-Ion	No	2000	1440	8/11/2008
5100000382111	Gene	Building 2	XTS 2500, WTSMTJ/RJ 1550	WNTN7974A	Li-Ion	No	2000	1440	8/21/2008
5100000384120	Bob	None	Galve	HW906126	NaClE	Yes	2000	1460	10/2/2008
5100000302111	Carroll	Administration	HT1G2/PRO Series	HW906246	NaOH	Yes	1890	1332	3/11/2009
5100000412887	Phil	Building 1	XTS 3000/3000/2000	WNTN4407B	NaOH	Yes	1700	1327	5/21/2008
5100000461380	Ben	Building 1	XTS 3000/3000/2000	HW906118	NaClE	No	1623	1047	8/5/2009
5100000439933	BB	Security	APR	WNTN7973A	Li-Ion	Yes	1600	2011	7/21/2009
5100000396202	Frank	Security	APR	WNTN7973A	NaOH	No	2100	1491	5/11/2008
5100000423258	Eric	Administration	MCT07780	PRM94077A	Li-Ion	No	2130	1526	2/18/2009
5100000436738	Henry	Administration	HT1G2/PRO Series	HW906246	NaClE	No	1160	1108	7/10/2009
5100000406241	Phil	Building 1	APR	WNTN7973A	NaOH	No	2100	1491	5/2/2008
5100000409482	Tom	Security	APR	WNTN7973A	Li-Ion	Yes	1600	2011	3/14/2009
5100000494217	Bill	Administration	HT1G2/PRO Series	HW906246	NaClE	No	1350	1109	5/2/2009
5100000484221	Steve	Building 2	XTS 3000/3000/2000	PRM94083A	NaOH	No	2000	1076	8/6/2007
5100000424188	Phil	Administration	MCT07780	PRM94083A	NaOH	Yes	1400	868	8/12/2008
5100000742323	Frank	Building 1	APR	WNTN7973A	NaOH	Yes	2000	1388	3/25/2008
5100000708112	Tom	Security	MCT07780	PRM94083A	Li-Ion	Yes	1400	868	8/12/2007
5100000705033	Henry	Administration	APR	WNTN7973A	NaOH	No	2100	1448	5/21/2008
5100000794458	Sam	Building 2	HT1G2/PRO Series	HW906126	NaOH	No	2000	1242	10/12/2007
5100000791386	Steve	Security	XTS 3000/3000/2000	WNTN4407B	Li-Ion	No	1610	2081	8/6/2008
5100000792121	Mark	Administration	APR	WNTN7973A	NaOH	No	2100	1448	8/1/2008
5100000797761	Mark	Building 1	MCT07780	PRM94083A	Li-Ion	No	1300	1033	10/11/2007

Figura 29: Informe de batería activa



Figura 30: Baterías en uso por familia de radios



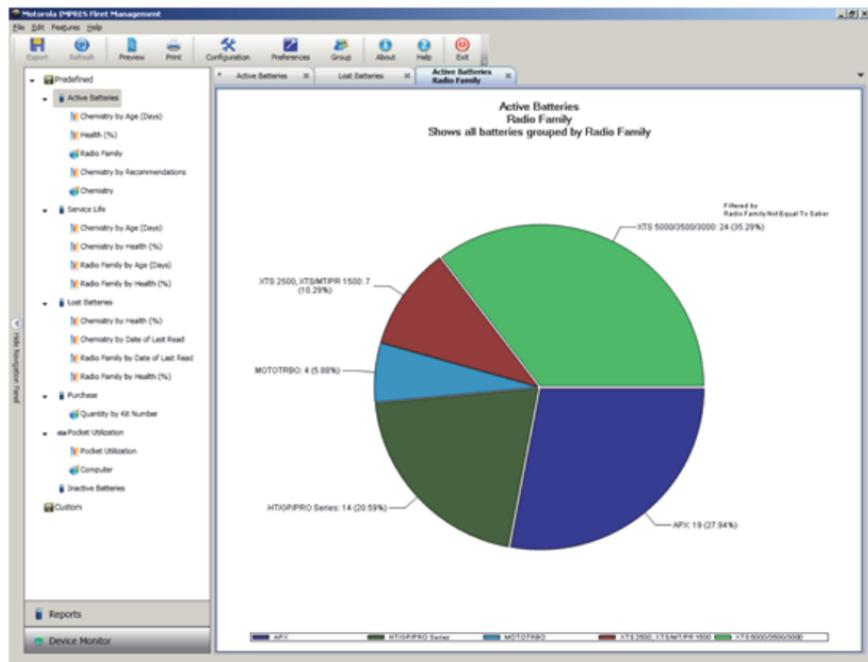

Figura 32: Utilización de la cavidad del cargador

## Montaje en pared del cargador para varias unidades

Un soporte de montaje en pared (número de pieza: 0705559L01) está disponible para el cargador para varias unidades. Comuníquese con su distribuidor local para solicitar este artículo. La instalación se muestra a continuación.

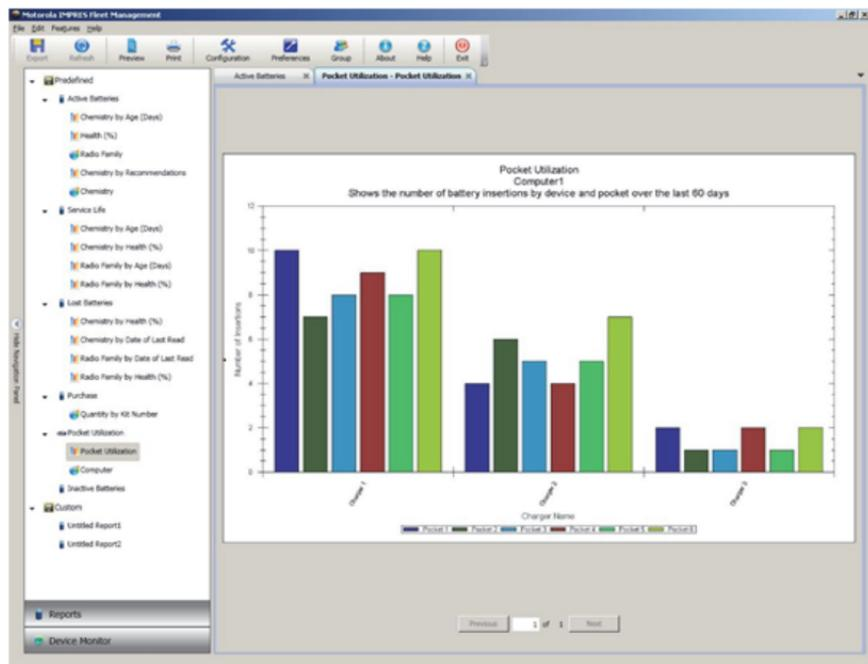

- Un técnico capacitado y con experiencia debe instalar este soporte de montaje de pared. Si un técnico no especializado instala el producto, puede ser muy peligroso y puede causar daños o lesiones.
- No instale el producto donde no se pueda soportar el peso. Si la ubicación donde se encuentra instalado el soporte de montaje en pared no es lo suficientemente resistente, este puede caerse y provocar lesiones.
- No lo instale en una estructura proclive a la vibración, al movimiento o a las posibilidades de impacto.

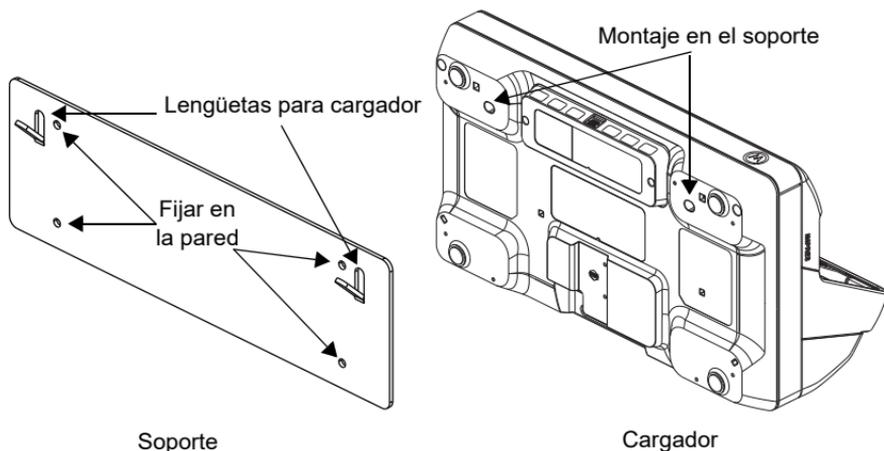

**Figura 33:** Orificios de montaje del soporte y posición de las lengüetas

## Montaje del cargador para varias unidades en el soporte de pared

1. Coloque el soporte de montaje en pared en la posición deseada y marque la ubicación de los orificios de montaje en la superficie de la pared.



Precaución

Asegúrese de que el área detrás de la superficie de montaje esté siempre libre de cables eléctricos, cables y tuberías antes de cortar, taladrar o instalar los tornillos de montaje.

2. Para instalar el soporte en la pared, use las herramientas de montaje adecuadas y necesarias para el tipo de fijación utilizado para el material de la pared en la que se realiza la instalación. Taladre según la marca de los orificios de montaje en las superficies de la pared.
  3. Para fijar el soporte de montaje en pared en su posición, instale firmemente las herramientas de montaje sobre los orificios del soporte de pared.
- Nota:** Se recomienda utilizar un tornillo roscador de 10-16 x 1,5" y una arandela (no incluida) sobre una viga de madera y una pared de concreto sólido liso o de ladrillos.
4. Cuelgue el cargador para varias unidades en el soporte de montaje en pared.

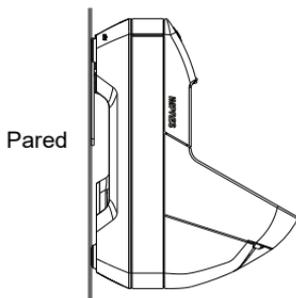

**Figura 34:** Cargador montado en el soporte de pared

# INSTRUÇÕES IMPORTANTES DE SEGURANÇA

## Guarde estas Instruções

Este documento contém instruções importantes de segurança e operação. Leia estas instruções com atenção e guarde-as para consulta futura.

Antes de utilizar o carregador da bateria, leia todas as instruções e observações de alerta sobre (1) o carregador, (2) a bateria e (3) o rádio que utiliza a bateria.



**AVISO**

1. Para reduzir o risco de danos ao cabo de energia, puxe pelo plugue e não pelo fio ao desconectar da tomada CA ou do carregador.
2. Não utilize uma extensão elétrica, a menos que seja absolutamente necessário. O uso de extensões inadequadas pode resultar em risco de incêndio e choque elétrico. Caso seja necessário utilizar uma extensão elétrica, verifique se o tamanho da extensão é 18 AWG para comprimentos de até 2 m (6,5 pés) e 16 AWG para comprimentos de até 3 m (9,8 pés).
3. Para reduzir o risco de incêndio, choque elétrico ou ferimentos, não utilize o carregador se ele estiver quebrado ou danificado de alguma forma. Leve-o a um representante qualificado de assistência técnica da Motorola Solutions.
4. Não desmonte o carregador. A desmontagem do carregador pode resultar em risco de choque elétrico ou incêndio. As únicas peças reparáveis/substituíveis são os Encaixes de Bolso NNTN9212 e NNTN9213. Siga as instruções nos Kits de Encaixe de Bolso do Carregador para Várias Unidades IMPRES 2 da Série APX MN005697A01.
5. Para reduzir o risco de choque elétrico, desconecte a fonte de alimentação do carregador da tomada de CA antes de realizar qualquer tipo de limpeza ou manutenção.



6. Para reduzir o risco de lesões, carregue apenas as baterias recarregáveis autorizadas da Motorola Solutions relacionadas na Tabela 2. Outras baterias podem explodir, causando lesões e danos pessoais.
7. O uso de acessórios não autorizados pela Motorola Solutions pode resultar em risco de incêndio, choque elétrico ou lesões.

## **Diretrizes de Segurança Operacional**

- Este equipamento não é adequado para utilização externa. Utilize-o somente em locais e condições secas.
- A temperatura máxima do ambiente em volta do carregador não deve ser superior a 40 °C (104 °F).
- Enquanto o rádio está no carregador, ele pode ser LIGADO somente se estiver transmitindo dados via conexão sem fio, como o uso do Wi-Fi. Caso contrário, DESLIGUE o rádio.
- Conecte o carregador somente a uma fonte de alimentação apropriada listada em Tabela 3.
- A tomada CA na qual o cabo de alimentação está conectado deverá estar próxima e ser facilmente acessada.
- Certifique-se de que o cabo da fonte de alimentação conectado ao carregador esteja localizado fora de locais de circulação para que não seja pisado, chutado, molhado, danificado ou esticado.
- Conecte o cabo de energia somente a uma tomada de CA com fusíveis e fios adequados e com a tensão correta, conforme especificado no produto.
- Desconecte da tensão de linha removendo o cabo de energia da tomada de CA.
- Não conecte mais que a quantidade apropriada de carregadores a um circuito de 15 A ou 20 A, conforme limitado por qualquer filtro de linha certificado sendo utilizado. **NÃO RECOMENDAMOS** usar filtros de linha de encadeamento em série. Limite o carregamento do circuito para abaixo de 80% de sua classificação.
- Use somente Compartimentos Autorizados da Motorola Solutions.

# Modelos Suportados

**Tabela 1: Modelos suportados e descrição**

Modelo	Descrição
PS000029A01 (UNIV) PS000029A04 (UE/RU) PS000029A06 (RK)	Carregador de Várias Unidades IMPRES 2 de 1 Visor APX com Reprogramação do Carregador e Gerenciamento de Frota IMPRES 2
PS000029A02 (UNIV) PS000029A05 (UE/RU) PS000029A07 (RK)	Carregador de Várias Unidades IMPRES 2 de 6 Visor com Reprogramação do Carregador e Gerenciamento de Frota IMPRES 2
PS000029A03 (UE/RU) PS000029A08 (RK)	Carregador de Várias Unidades IMPRES 2 de 6 Visores APX com Reprogramação do Carregador, Gerenciamento de Frota e Carregamento via Acessório USB
PS000337A01 (EUA/ AMÉRICA DO NORTE, AUSTRÁLIA/NOVA ZELÂNDIA)	Carregador de Várias Unidades IMPRES 2 de 6 Visores APX NEXT com Reprogramação do Carregador e Gerenciamento de Frota

## Baterias Autorizadas da Motorola Solutions

Os Carregadores IMPRES 2 da Série APX carregarão as baterias listadas na Tabela 2. As baterias podem estar conectadas ao rádio ou podem ser autônomas.

**Tabela 2: Baterias Autorizadas da Motorola Solutions**

Kit (PN)	Descrição
NNTN7033	IMPRES de Íon de Lítio com FM (HazLoc) IP67 de 4100 mAh
NNTN7034	IMPRES de Íon de Lítio IP67 de 4200 mAh
NNTN7035	NiMH IMPRES com FM (HazLoc) Resistente de 2000 mAh
NNTN7036	NiMH IMPRES com FM (HazLoc) IP67 de 2000 mAh
NNTN7037	NiMH IMPRES IP67 de 2100 mAh
NNTN7038	IMPRES de Íon de Lítio IP67 de 2900 mAh
NNTN7573	NiMH IMPRES Resistente de 2100 mAh
NNTN8092	IMPRES de Íon de Lítio com FM (HazLoc) Resistente de 2300 mAh
NNTN8182	IMPRES de Íon de Lítio Resistente de 2900 mAh
NNTN8921	Íon de Lítio TIA4950 IMPRES 2 (HazLoc) Resistente IP67 de 3700 mAh
NNTN8930	Íon de Lítio TIA4950 IMPRES 2 (HazLoc) Resistente IP67 de 2700 mAh

**Tabela 2: Baterias Autorizadas da Motorola Solutions (Continuação)**

Kit (PN)	Descrição
NNTN9087	IMPRES 2 de Íon de Lítio IP68 de 3800 mAh
NNTN9088	Íon de Lítio IMPRES 2 DIVISION 2 (HazLoc) IP68 de 3800 mAh
NNTN9089	IMPRES 2 de Íon de Lítio IP68 de 5650 mAh
NNTN9090	Íon de Lítio IMPRES 2 DIVISION 2 (HazLoc) IP68 de 5650 mAh
NNTN9126	IMPRES 2 de Íon de Lítio IP68 de 4400 mAh
NNTN9127	Íon de Lítio IMPRES 2 DIVISION 2 (HazLoc) IP68 de 4400 mAh
PMNN4403	IMPRES de Íon de Lítio IP67 de 2150 mAh
PMNN4485	Íon de Lítio IMPRES 2 Resistente IP67 de 2500 mAh
PMNN4486	Íon de Lítio IMPRES 2 Resistente IP67 de 3400 mAh
PMNN4487	Íon de Lítio IMPRES 2 Resistente IP67 de 4400 mAh
PMNN4494	Íon de Lítio IMPRES 2 Resistente IP67 de 5000 mAh
PMNN4504	Íon de Lítio IMPRES 2 DIVISION 2 (HazLoc) Resistente IP67 de 3400 mAh
PMNN4505	Íon de Lítio IMPRES 2 DIVISION 2 (HazLoc) Resistente IP67 de 4850 mAh
PMNN4547	Íon de Lítio TIA4950 IMPRES 2 (HazLoc) Resistente IP68 de 3100 mAh
PMNN4573	Íon de Lítio TIA4950 IMPRES 2 (HazLoc) Resistente IP68 de 4600 mAh
PMNN4812	APX NEXT XN IMPRES 2 Íon de Lítio DIV 2 (HAZLOC) IP68 3400 mAh

## Fontes de alimentação autorizadas pela Motorola Solutions

**Tabela 3: Fontes de alimentação autorizadas pela Motorola Solutions**

Kit (PN)	Descrição
3087791G01	Cabo de Alimentação, EUA/América do Norte
3087791G04	Cabo de Alimentação, UE
3087791G07	Cabo de Alimentação, RU/Hong Kong
3087791G10	Cabo de Alimentação, Austrália/Nova Zelândia
3087791G13	Cabo de Alimentação, AR
3087791G16	Cabo de Alimentação, KR
3087791G20	Cabo de Alimentação, JP
3087791G22	Cabo de Alimentação, BR
CB000460A01	Cabo de Alimentação, CH

# Módulos de Comunicação Autorizados da Motorola Solutions

**Tabela 4:** Módulos de Comunicação Autorizados da Motorola Solutions

Kit (PN)	Descrição
AS000013A01	Reprogramação de Carregador e Módulo de Gerenciamento de Frota de Bateria IMPRES 2
AS000012A02	Módulo de Reprogramação de Carregador/Gerenciamento de Frota de Bateria e Módulo de Carregamento de Acessório IMPRES 2

## Carregador, Compartimento e Módulo de Comunicações

O Sistema do Carregador Adaptável IMPRES 2™ Série APX é um sistema de manutenção de bateria totalmente automatizado. O carregador está equipado com os seguintes recursos:

- Carregamento adaptável para acomodar uma ampla variedade de tipos de bateria, incluindo IMPRES 2, IMPRES™ e outras baterias originais da Motorola Solutions.
- Compartimento que acomoda uma bateria autônoma ou um rádio com bateria conectada
- Status de compartimentos indicado por LED Vermelho/Laranja/Verde.
- Módulo de Comunicações
  - Reprogramação do carregador
  - Carregamento de dados da bateria IMPRES 2 ou IMPRES para um Sistema de Gerenciamento de Frota de Baterias IMPRES
  - (Opcional) Seis portas de carregamento USB Tipo A, cada uma com 0,5 A para o carregamento de um acessório USB
- Menu de Teclado
  - Configuração do Carregador
  - Análise da Bateria
- Exibição de Informações no Compartimento nº 1.
  - Visores opcionais em outros compartimentos

- Preparação de uma bateria autônoma IMPRES 2 ou IMPRES para armazenamento de longo prazo ou preparação de uma bateria autônoma de íon de lítio da Motorola Solutions para remessa. NÃO deixe as baterias no carregador após concluir o preparo para armazenamento de longo prazo ou para remessa de íons de lítio.
- Recursos de Eficiência de Energia
  - Em conformidade com os padrões da California Energy Commission para pequenos sistemas de carregamento de baterias. Os compartimentos de carregamento vão entrar em modo suspenso automaticamente e depois sair dele para responder à ação do usuário ou para o serviço de uma bateria no compartimento.
  - Em conformidade com os Limites Europeus de Corrente em Espera (Kit de Carregador Europeu). Quando o Modo de Economia de Energia está habilitado, todos os compartimentos do carregador, exceto o Compartimento nº 1, serão desligados automaticamente quando não houver nenhuma atividade por um período de tempo. Pressione qualquer botão do Teclado para ligar esses compartimentos novamente.
- Carregamento de bateria de íon de Lítio IMPRES 2 de alta taxa.
- Carregamento mais rápido.
- Vida útil da bateria prolongada.

Não é recomendável operar um rádio enquanto ele estiver no carregador.

Operar o rádio durante o processo de carregamento pode resultar na redução mínima do desempenho do rádio e na extensão do tempo de carga da bateria.

Durante a Calibração/Recondicionamento, a bateria estará totalmente descarregada antes de ser totalmente carregada. Consequentemente, o rádio pode desligar durante a fase de recarga. É recomendável calibrar a bateria sem o rádio conectado ou com o rádio conectado desativado.

# Baterias e Carregadores IMPRES 2 e IMPRES

## Recursos e benefícios

A solução de energia IMPRES 2 é um sistema de energia avançado com Química Tripla desenvolvido pela Motorola Solutions. Este sistema inclui:

- Baterias IMPRES 2 e IMPRES
- Carregador Adaptável IMPRES 2
- Rádios IMPRES

Ao carregar baterias IMPRES 2 ou IMPRES usando um Carregador Adaptável IMPRES 2 que calibra ou recondiciona a bateria periodicamente, você tem os seguintes benefícios:

- Prolonga a vida útil da bateria.
- Mede a capacidade da bateria e determina o atual estado de carga dela, dando a você uma indicação de uso eficiente do tempo.
- Monitora o padrão de uso da bateria IMPRES 2 ou IMPRES.
- Atualiza as informações de padrão armazenadas na bateria IMPRES 2 ou IMPRES.
- Realiza automaticamente a Calibração/Recondicionamento somente conforme necessário.
- Minimiza o aquecimento da bateria IMPRES 2 ou IMPRES, independente de quanto tempo a bateria for deixada no compartimento.
- "Completa" periodicamente uma bateria armazenada no compartimento do carregador, mantendo um estado de alta disponibilidade para o usuário.
- Acaba com o efeito de memória em baterias de Níquel, eliminando a necessidade de comprar equipamentos especiais ou treinar funcionários em tarefas para manter o ciclo de vida útil da bateria.

Usando esse exclusivo sistema patenteado, não é necessário controlar nem registrar o uso da bateria IMPRES 2 ou IMPRES, realizar Calibração/Recondicionamento manual nem remover as baterias dos carregadores após o término do carregamento.

## Inicialização da Bateria IMPRES 2 ou IMPRES

Para plena funcionalidade da IMPRES 2 ou IMPRES, uma nova bateria IMPRES 2 ou IMPRES deve ser inicializada pelo carregador. O carregador detecta automaticamente a nova bateria IMPRES 2 ou IMPRES e inicia automaticamente a Inicialização. A inicialização é a primeira Calibração/Recondicionamento de uma bateria IMPRES 2 ou IMPRES. Esse é um processo de duas etapas. A primeira etapa é a Descarga da Bateria, indicada pelo LED **Âmbar Constante**. A segunda etapa é a carga máxima, eventualmente indicada pelo LED **Verde Constante**. Esse processo pode levar até 12 horas ou mais para ser concluído, dependendo do estado da carga e capacidade de carga da bateria. A interrupção de cada etapa atrasa a Inicialização até a próxima oportunidade de carregamento.

## Compartimento a Compartimento IMPRES 2 ou IMPRES

Ao carregar baterias IMPRES 2 ou IMPRES, o carregador IMPRES 2 ou IMPRES registra as informações de carregamento na memória da bateria. Se a bateria IMPRES 2 ou IMPRES for removida de um compartimento de carregador IMPRES 2 ou IMPRES e, em até 30 minutos, for inserida em outro ou no mesmo compartimento, o carregamento continuará do ponto de onde foi interrompido. Esse recurso evita o sobrecarregamento da bateria e minimiza a perda de vida útil. Isso é especialmente importante ao carregar baterias de Níquel.

## Calibração/Recondicionamento Automático da Bateria IMPRES 2 ou IMPRES

O carregador IMPRES 2 avalia automaticamente a condição de uma bateria IMPRES 2 ou IMPRES. Com base nessas condições, o carregador calibra/recondiciona automaticamente a bateria. A interrupção da etapa de descarga ou de carregamento completo atrasa a Calibração até a próxima oportunidade de carregamento.

Use o carregador do modo de configuração para ativar ou desativar a Calibração/Recondicionamento. Quando desabilitada e quando a bateria IMPRES 2 ou IMPRES precisar de Calibração/Recondicionamento, o LED indicará em **Âmbar/Verde Intermitente** na inserção da bateria e depois do carregamento dela.

**Nota:** a bateria IMPRES 2 ou IMPRES deve estar fora de um compartimento do carregador por mais de 30 minutos para Calibração/Recondicionamento automático.

## Bateria IMPRES com Autocalibração e Recondicionamento



**ATENÇÃO:** as baterias IMPRES 2 que têm esse ícone na etiqueta da bateria não exigem calibração e recondicionamento periódicos quando encaixadas neste carregador IMPRES 2 (com a versão de software V2.05 ou mais recente).

**Nota:** certifique-se de que o carregador esteja sempre atualizado com o firmware mais recente. O pacote do aplicativo Reprogramador do Carregador MSI pode ser baixado no Motorola Online (MOL) ou no site da Motorola Solutions.

### Atualização do firmware

**Nota:** aplica-se a todos os dispositivos ou carregadores IMPRES Gen 1 e Gen 2, incluindo unidade de interface do carregador (CIU, Charger Interface Unit); leitor de dados da bateria (BDR, Battery Data Reader); carregador de uma unidade (SUC, Single-Unit Charger), carregador de duas unidades (DUC, Dual-Unit Charger); e carregador de várias unidades (MUC, Multi-Unit Charger).

Remova todas as baterias inseridas do dispositivo ou carregador de destino antes de atualizar um dispositivo ou carregador IMPRES para uma versão mais recente.



1. Conecte o dispositivo ou carregador ao seu computador usando USB. O dispositivo ou carregador conectado é mostrado na janela principal do MSI Charger Reprogrammer (Reprogramador do Carregador MSI).

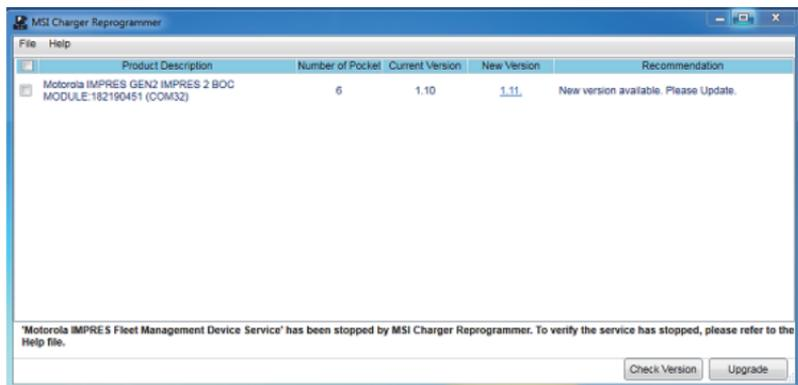

2. Clique em Check Version (Verificar versão) para encontrar a versão mais recente disponível no servidor MSI.

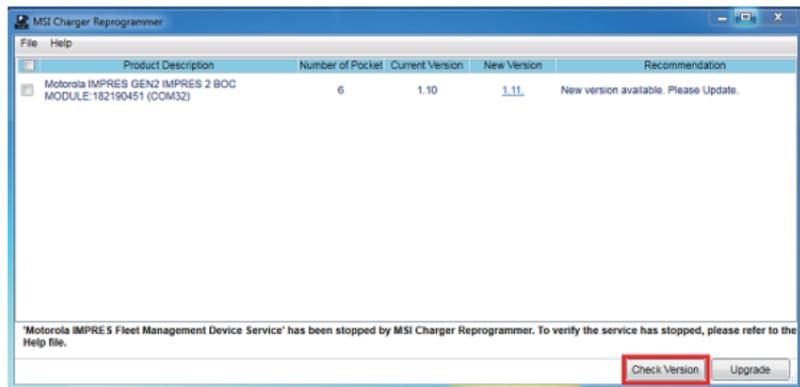

### 3. Selecione o dispositivo ou carregador que requer atualização.

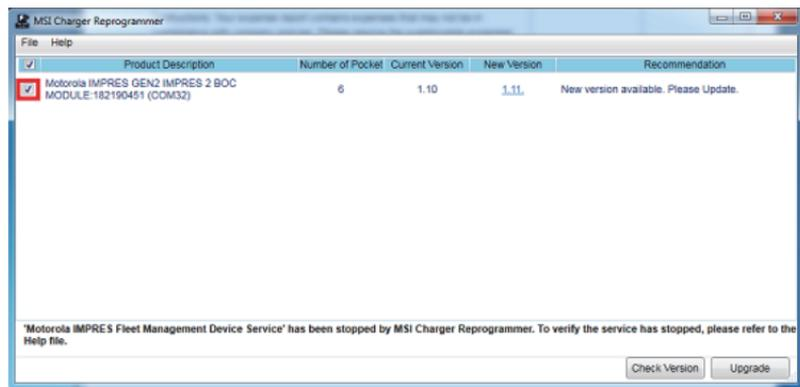

**Nota:** não é possível selecionar o dispositivo ou carregador já atualizado com a versão mais recente do firmware.

### 4. Para iniciar a atualização do firmware, clique em Upgrade (Atualizar).

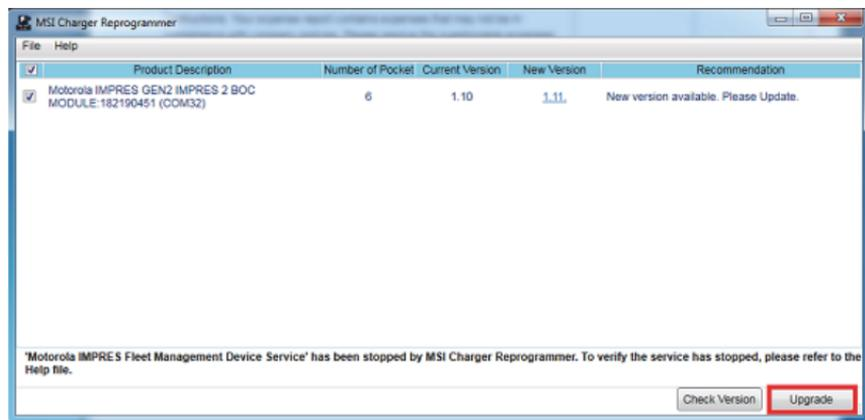

5. Clique em OK na janela de confirmação quando solicitado para iniciar a atualização. Uma janela mostra o progresso da atualização até a conclusão.

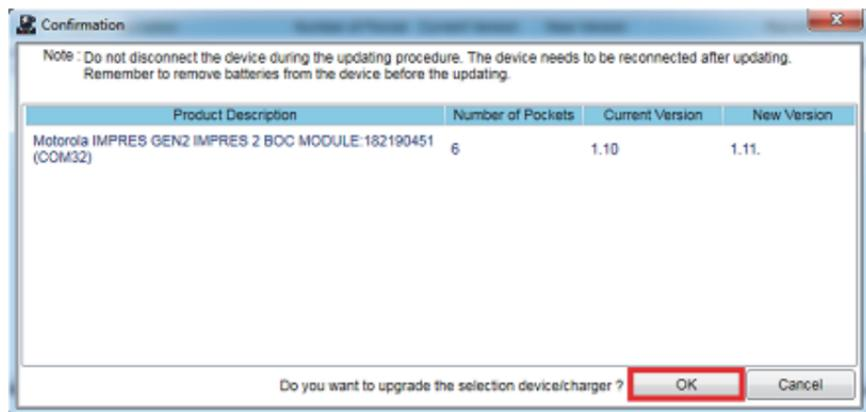

6. Feche a janela quando todas as atualizações tiverem sido concluídas.

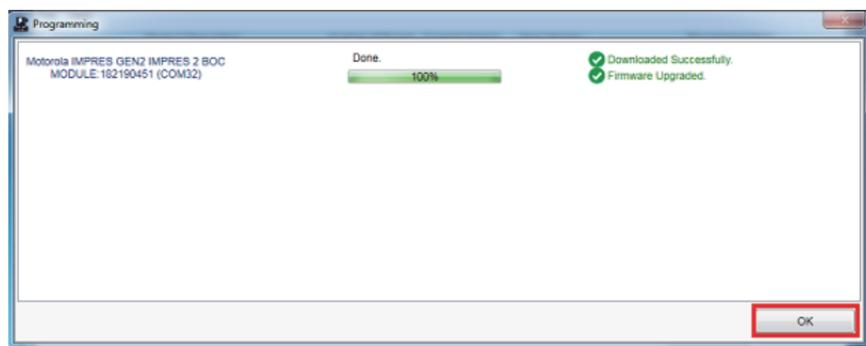

## Inicialização Manual da Calibração/do Recondicionamento



**ATENÇÃO:** a calibração ou recondicionamento manual não se aplica a baterias IMPRES ou IMPRES 2 que tenham este ícone.

Embora a Calibração/o Recondicionamento seja automático, poderá haver situações em que é preferível a iniciação manual. Por exemplo, o carregador pode estar indicando **Âmbar/Verde Intermitente** para a bateria IMPRES 2 ou IMPRES porque a Calibração está desabilitada no carregador. Se, em até 30 minutos, essa bateria for transferida para um carregador com calibração habilitada, o último estado de carregamento será retomado, impedindo a inicialização automática da Calibração/Recondicionamento.

Para iniciar manualmente a Calibração/Recondicionamento, certifique-se de que a bateria IMPRES 2 ou IMPRES seja removida do carregador por mais de dois minutos e meio. Em seguida, execute as seguintes etapas:

1. Insira a bateria no compartimento do carregador.
2. Em até dois minutos e meio, remova a bateria do compartimento do carregador.
3. Em até 5 segundos, insira novamente a bateria no compartimento do carregador.

A Calibração/o Recondicionamento é iniciado imediatamente, geralmente começando com a descarga da bateria (**Amarelo Constante**). A Calibração/o Recondicionamento só está completo após a carga completa (**Verde Constante**).

## **Encerramento Manual da Calibração/do Recondicionamento**

A qualquer momento durante a descarga da bateria IMPRES 2 ou IMPRES (Amarelo Constante), a Calibração/Recondicionamento poderá ser encerrada realizando as seguintes etapas:

1. Retire a bateria do compartimento do carregador.
2. Em até 5 segundos, insira novamente a bateria no compartimento do carregador.

A descarga da bateria é encerrada imediatamente e o carregamento normal da bateria é iniciado. O LED indica o Status da Carga.

# Visão Geral do Carregador



Figura 1: Visão Geral do Carregador

Tabela 5: Visão Geral e Descrição do Carregador

Número	Nome	Descrição
1 a 6	Compartimentos do carregador	Cada compartimento acomoda uma bateria independente ou rádio compatível
7	Módulo de Comunicações	Em determinados carregadores, o Módulo de Comunicações também carrega os acessórios USB: <ul style="list-style-type: none"><li>• UE/RU PS000029A03</li><li>• RK PS000029A08</li></ul>
8	Indicador de Status de LED do Compartimento	LED de Status da Carga (um por compartimento)
9	Display	Visor opcional para outros compartimentos que não o Compartimento nº 1
10	Visor do Teclado	Visor do Compartimento nº 1 com Teclado de Menu
11	Entrada de Alimentação CA	Usa o cabo de alimentação específico para o país ou região

## Indicação de LED para Fim de Vida Útil da IMPRES 2 ou IMPRES

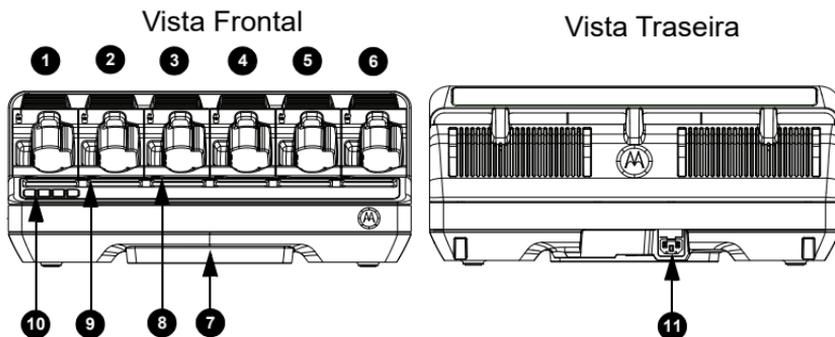
O carregador pode indicar o Fim de Vida Útil da bateria IMPRES 2 ou IMPRES (**Vermelho/Verde Intermitente**) após a conclusão da Calibração/Recondicionamento.

Conforme as baterias são usadas, o desgaste normal reduz a capacidade disponível. Após o término bem-sucedido da Calibração/Recondicionamento, o carregador compara a capacidade da bateria IMPRES 2 ou IMPRES com a capacidade nominal da bateria. Quando a capacidade está em um valor muito baixo, é possível que a bateria IMPRES 2 ou IMPRES esteja chegando ao fim da vida útil. A bateria IMPRES 2 ou IMPRES permanece utilizável. Em alguns casos, pode ser preferível que alguém que não necessite de uma grande capacidade da bateria para concluir um turno de trabalho use a bateria.

A bateria APX NEXT XN vem com um recurso de detecção de alta temperatura no carregador IMPRES 2 com a versão de software V2.05 ou mais recente. Quando esse recurso está ativado, o LED de status pisca em vermelho e verde alternadamente após a conclusão da carga da bateria que passou por exposição prolongada em ambiente com temperatura extremamente alta. O carregador exibe o seguinte:

REPLACE BATTERY  
EXPOSED OVERTEMP

Recomenda-se retirar essa bateria do serviço.

## Carregando baterias ou rádios com baterias conectadas

O carregamento da bateria é mais eficiente em temperatura ambiente. Os Carregadores para Várias Unidades IMPRES 2 podem carregar uma bateria independente ou uma bateria anexada a um rádio.

1. Posicione o carregador em uma superfície plana.
2. Insira o cabo de alimentação com firmeza no Soquete de Entrada CA do carregador na parte traseira dele.
3. Conecte o cabo de alimentação em uma tomada de energia correspondente.
4. Após a ativação bem-sucedida, cada LED de Status de Carga acenderá na cor **Verde** por cerca de um segundo, e IMPRES 2 CHARGER será exibido. Se os LEDs de Status de Carga não piscarem e nenhuma mensagem for exibida, verifique as duas conexões do cabo da fonte de alimentação.
5. Insira um rádio com bateria conectada ou uma bateria independente em um compartimento disponível.

**Nota:** segure o corpo do rádio ao inseri-lo ou removê-lo do carregador. Evite puxar a antena de rádio.

6. Quando a bateria independente ou o rádio estiver devidamente encaixado no compartimento, o status de carregamento será indicado pelo LED de Status de Carga associado. O Visor associado fornece informações adicionais. Para carregadores de visor único, o visor fornece o status de carregamento apenas do Compartimento nº 1.
7. A bateria estará pronta para uso quando o status de carregamento for **Verde Constante**.
8. Ligue o rádio somente quando o Módulo de Comunicações do Carregador for removido de um PC. Caso contrário, DESLIGUE o dispositivo ou rádio.

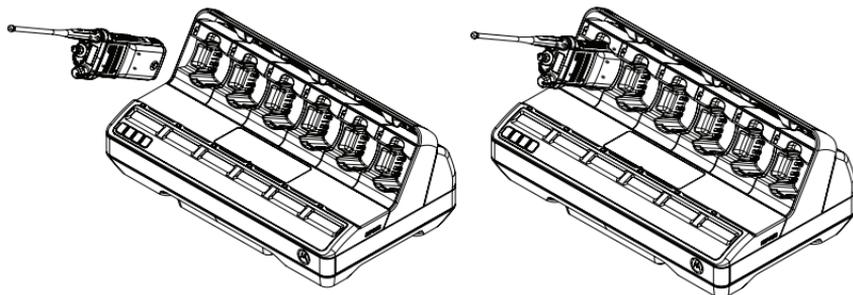

**Figura 2:** Carregando Bateria Conectada ao Rádio

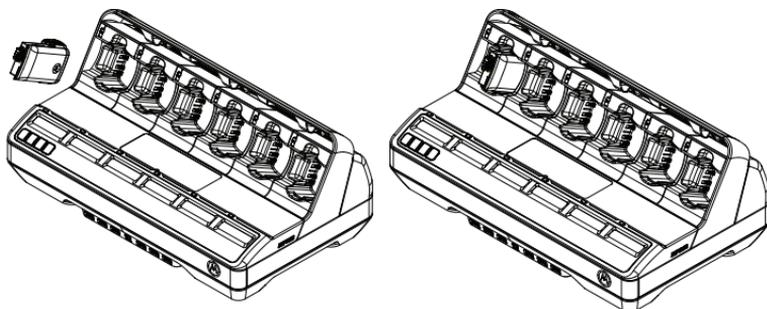

**Figura 3:** Carregando Bateria Independente

## Carregando Acessórios USB

Alguns Módulos de Comunicações de Carregador para Várias Unidades IMPRES 2 fornecem soquetes USB do Tipo A para carregar os acessórios USB. O carregamento de acessórios USB é mais eficiente em temperatura ambiente.

1. Coloque o Carregador Adaptável IMPRES 2 em uma superfície plana.
2. Insira o cabo de alimentação com firmeza no Soquete de Entrada CA do carregador na parte traseira do carregador.
3. Conecte o cabo de alimentação em uma tomada de energia correspondente.
4. Após a ativação bem-sucedida, cada LED de Status do compartimento piscará na cor **Verde** por um segundo e `IMPRES 2 CHARGER` será exibido. Se os LEDs de Status não piscarem e nenhuma mensagem for exibida, verifique as conexões do cabo de alimentação.
5. Um acessório USB pode ter um receptáculo Micro-AB para carregamento. Use um cabo USB padrão de 1 metro ou mais curto com um plugue do Tipo A em uma extremidade e um plugue compatível com o acessório na outra (normalmente Micro-B ou Micro-AB).
6. Posicione o plugue Tipo A do cabo USB para alinhá-lo corretamente à porta Tipo A no Módulo de Comunicações. Insira o plugue na porta.
7. Posicione o plugue Micro-B do cabo USB para alinhá-lo corretamente ao receptáculo Micro-AB no acessório USB. Insira o plugue no acessório receptáculo.
8. Quando as conexões USB estiverem devidamente encaixadas, o status de carregamento será indicado pelo acessório USB. Consulte o Guia do Usuário do acessório USB para obter detalhes.



## Indicações de carregamento

**Tabela 6:** Indicações de carregamento para Bateria IMPRES 2 ou IMPRES – Calibração não Obrigatória

Status	Visor de Compartimento	Indicador de LED
Carregador Ligado	IMPRES 2 CHARGER	Verde por aproximadamente um segundo 
Bateria Detectada	IMPRES 2 BATTERY OU IMPRES BATTERY	Vermelho Constante 
Carregamento Rápido	RAPID CHARGE xxxxx0mAh yy%Pt1	Vermelho Constante 
Carregado em 90% ou mais	TRICKLE CHARGE xxxxx0mAh yy%Pt1	Verde Piscando 
Carregado em 95% ou mais	CHARGE COMPLETE xxxxx0mAh yy%Pt1	Verde Constante 
Falha	AVISO: NOT CHARGEABLE REMOVE & REINSERT	Vermelho Piscando 
Standby <ul style="list-style-type: none"><li>A bateria está aguardando carregamento rápido.</li><li>A bateria está muito quente, muito fria ou com baixa tensão.</li><li>O carregador está muito quente.</li></ul>	AVISO: HOT BATTERY WAITING TO CHARGE OU COLD BATTERY WAITING TO CHARGE OU VERY LOW BATTERY WAITING TO CHARGE OU HOT CHARGER WAITING TO CHARGE	Âmbar Piscando 

### Nota:

- A mensagem **Hot Charger** foi introduzida no software V1.05.
- As indicações de porcentagem do Estado do Carregador, em relação à Capacidade Potencial versus Capacidade Nominal, foram introduzidas no software V1.11.01.

**Tabela 7:** Indicações de Carregamento para Calibração de Bateria IMPRES 2 ou IMPRES – Calibração Habilitada

Status	Visor de Compartimento	Indicador de LED
Carregador Ligado	IMPRES 2 CHARGER	Verde por aproximadamente um segundo 
Bateria Detectada	IMPRES 2 BATTERY OU IMPRES BATTERY	Âmbar Contínuo 
Descarregamento da Bateria	CAL DISCHARGE xxxxx0mAh yyy%Pt1	Âmbar Contínuo 
Carregamento Rápido	CAL RAPID CHARGE xxxxx0mAh yyy%Pt1	Vermelho Constante 
Carregado em 90% ou mais	CAL TRICKLE CHARGE xxxxx0mAh yyy%Pt1	Verde Piscando 
Carregado em 95% ou mais	CALIBRAÇÃO BEM-SUCEDIDA CHARGE COMPLETE xxxxx0mAh yyy%Pt1	Calibração da Bateria bem-sucedida: Verde Constante   Calibração da Bateria bem-sucedida, mas ela pode estar próxima do Fim de Vida Útil (a bateria pode ser usada): Vermelho/Verde 
	REPLACE BATTERY EXPOSED OVERTEMP	A calibração da bateria foi concluída com sucesso, mas a bateria foi exposta a superaquecimento cumulativo (recomenda-se retirar da frota): Vermelho/Verde Piscando NOTA: aplicável somente para bateria APX NEXT XN 
Falha	AVISO: NOT CHARGEABLE REMOVE & REINSERT	Vermelho Piscando 

**Tabela 7:** Indicações de Carregamento para Calibração de Bateria IMPRES 2 ou IMPRES – Calibração Habilitada (Continuação)

Status	Visor de Compartimento	Indicador de LED
<p>Standby</p> <ul style="list-style-type: none"> <li>• A bateria está aguardando carregamento rápido.</li> <li>• A bateria está muito quente, muito fria ou com baixa tensão.</li> <li>• O carregador está muito quente.</li> </ul>	<p>AVISO:</p> <p>HOT BATTERY WAITING TO CAL OU</p> <p>COLD BATTERY WAITING TO CAL OU</p> <p>VERY LOW BATTERY WAITING TO CHARGE OU</p> <p>HOT CHARGER WAITING TO CAL</p>	<p>Âmbar Piscando</p> 

**Tabela 8:** Indicações de Carregamento para Calibração de Bateria IMPRES 2 ou IMPRES – Calibração inicialmente Desabilitada, depois Habilitada

Status	Visor do Carregador	Indicador de LED
Carregador Ligado	IMPRES 2 CHARGER	Verde por aproximadamente um segundo 
Bateria Detectada	IMPRES 2 BATTERY ou IMPRES BATTERY	A Bateria requer Calibração, mas a Calibração está desabilitada no carregador: Alternando entre Âmbar/ Verde por 4 segundos  
Solicitando Calibração da Bateria IMPRES • A calibração está desabilitada no carregador. • A bateria está carregando	AVISO: ENABLE BATTERY CALIBRATION?  • Pressione OK para ativar a Calibração • Ignore para carregamento normal (mensagem removida após 1 minuto)	Vermelho Constante 
Descarregamento da Bateria • OK selecionado	CAL DISCHARGE xxxxx@mAh yyy%P t1	Âmbar Contínuo 
Carregamento Rápido	CAL RAPID CHARGE xxxxx@mAh yyy%P t1	Vermelho Constante 
Carregado em 90% ou mais	CAL TRICKLE CHARGE xxxxx@mAh yyy%P t1	Verde Piscando 

**Tabela 8:** Indicações de Carregamento para Calibração de Bateria IMPRES 2 ou IMPRES – Calibração inicialmente Desabilitada, depois Habilitada (Continuação)

Status	Visor do Carregador	Indicador de LED
Carregado em 95% ou mais	<p>CHARGE COMPLETE xxxxx@mAh yyy%P t1</p>	<p>Calibração da Bateria bem-sucedida: Verde Constante </p> <p>Calibração da Bateria bem-sucedida, mas ela pode estar próxima do Fim de Vida Útil (a bateria pode ser usada): Vermelho/Verde </p>
	<p>REPLACE BATTERY EXPOSED OVERTEMP</p>	<p>A calibração da bateria foi concluída com sucesso, mas a bateria foi exposta a superaquecimento cumulativo (recomenda-se retirar da frota): Vermelho/Verde Piscando NOTA: aplicável somente para bateria APX NEXT XN </p>
Falha	<p>AVISO: NOT CHARGEABLE REMOVE&amp; REINSERT</p>	<p>Vermelho Piscando </p>
<p>Standby</p> <ul style="list-style-type: none"> <li>• A bateria está aguardando carregamento rápido.</li> <li>• A bateria está muito quente, muito fria ou com baixa tensão.</li> <li>• O carregador está muito quente.</li> </ul>	<p>AVISO: HOT BATTERY WAITING TO CAL OU COLD BATTERY WAITING TO CAL OU VERY LOW BATTERY WAITING TO CHARGE OU HOT CHARGER WAITING TO CAL</p>	<p>Âmbar Piscando </p>

**Tabela 9:** Indicações de carregamento para Bateria IMPRES 2 ou IMPRES – Calibração Obrigatória, mas não Habilitada

Status	Visor do Carregador	Indicador de LED
Carregador Ligado	IMPRES 2 CHARGER	Verde por aproximadamente um segundo 
Bateria Detectada	IMPRES 2 BATTERY ou IMPRES BATTERY	A Bateria requer Calibração, mas a Calibração está desabilitada no carregador: Alternando entre Âmbar/ Verde por 4 segundos 
Solicitando Calibração da Bateria IMPRES <ul style="list-style-type: none"><li>A calibração está desabilitada no carregador.</li><li>A bateria está carregando.</li></ul>	AVISO: ENABLE BATTERY CALIBRATION?  <ul style="list-style-type: none"><li>Pressione OK para ativar a Calibração.</li><li>Ignore para carregamento normal (mensagem removida após 1 minuto).</li></ul>	Vermelho Constante 
Carregamento Rápido <ul style="list-style-type: none"><li>Tempo da Solicitação de Calibração esgotado.</li></ul>	RAPID CHARGE xxxxx@mAh yyy%P t1	Vermelho Constante 
Carregado em 90% ou mais	TRICKLE CHARGE xxxxx@mAh yyy%P t1	Verde Piscando 
Carregado em 95% ou mais	CHARGE COMPLETE xxxxx@mAh yyy%P t1	Alternando Âmbar/Verde 
Falha	AVISO: NOT CHARGEABLE REMOVE& REINSERT	Vermelho Piscando 
Standby <ul style="list-style-type: none"><li>A bateria está aguardando carregamento rápido.</li><li>A bateria está muito quente, muito fria ou com baixa tensão.</li><li>O carregador está muito quente.</li></ul>	AVISO: HOT BATTERY WAITING TO CHARGE OU COLD BATTERY WAITING TO CHARGE OU VERY LOW BATTERY WAITING TO CHARGE OU HOT CHARGER WAITING TO CHARGE	Âmbar Piscando 

**Tabela 10:** Indicações de Carregamento para Bateria IMPRES 2 ou IMPRES Totalmente Carregada – Calibração Obrigatória, mas não Habilitada

Status	Visor do Carregador	Indicador de LED
Carregador Ligado	IMPRES 2 CHARGER	Verde por aproximadamente um segundo 
Bateria Detectada	IMPRES 2 BATTERY ou IMPRES BATTERY	A bateria requer Calibração, mas foi totalmente carregada nos últimos 30 minutos e a calibração está desabilitada no carregador: Alternando Âmbar/Verde 
Falha	AVISO: NOT CHARGEABLE REMOVE& REINSERT	Vermelho Piscando 
Standby <ul style="list-style-type: none"> <li>• A bateria está aguardando carregamento rápido.</li> <li>• A bateria está muito quente, muito fria ou com baixa tensão.</li> <li>• O carregador está muito quente.</li> </ul>	AVISO: HOT BATTERY WAITING TO CHARGE OU COLD BATTERY WAITING TO CHARGE OU VERY LOW BATTERY WAITING TO CHARGE OU HOT CHARGER WAITING TO CHARGE	Âmbar Piscando 

## Outras Baterias da Motorola Solutions

**Tabela 11:** Indicações de Carregamento para Outras Baterias da Motorola Solutions

Status	Visor do Carregador	Indicador de LED
Carregador Ligado	IMPRES 2 CHARGER	Verde por aproximadamente um segundo 
Bateria Detectada	MOTOROLA SOLUTIONS BATTERY	Vermelho Constante 
Carregamento Rápido	RAPID CHARGE	Vermelho Constante 
Carregado em 90% ou mais	TRICKLE CHARGE	Verde Piscando 
Carregado em 95% ou mais	CHARGE COMPLETE	Verde Constante 
Falha	AVISO: NOT CHARGEABLE REMOVE & REINSERT	Vermelho Piscando 
Standby <ul style="list-style-type: none"> <li>• A bateria está aguardando carregamento rápido.</li> <li>• A bateria está muito quente, muito fria ou com baixa tensão.</li> <li>• O carregador está muito quente.</li> </ul>	AVISO: HOT BATTERY WAITING TO CHARGE OU COLD BATTERY WAITING TO CHARGE OU VERY LOW BATTERY WAITING TO CHARGE OU HOT CHARGER WAITING TO CHARGE	Âmbar Piscando 



## Bateria Desconhecida

Algumas baterias desconhecidas podem não ser detectáveis pelo carregador. Baterias desconhecidas não declaram parâmetros de carregamento de maneira reconhecível pelo carregador. Se uma bateria desconhecida for detectada, o carregador indicará o carregamento, conforme descrito em Tabela 12.

**Tabela 12:** Indicações de Carregamento para Baterias Desconhecidas

Status	Visor do Carregador	Indicador de LED
Carregador Ligado	IMPRES 2 CHARGER	Verde por aproximadamente um segundo 
Bateria Detectada	UNKNOWN BATTERY	Vermelho Constante 
Carregamento Rápido	RAPID CHARGE	Vermelho Constante 
Quase Carregada • Capacidade da Bateria Desconhecida	TRICKLE CHARGE	Verde Piscando 
Carregado • Capacidade da Bateria Desconhecida	CHARGE COMPLETE	Verde Constante 
Falha	AVISO: HOT CHARGEABLE REMOVE & REINSERT	Vermelho Piscando 
Standby • A bateria está aguardando carregamento rápido. • A bateria está muito quente, muito fria ou com baixa tensão. • O carregador está muito quente.	AVISO: HOT BATTERY WAITING TO CHARGE OU COLD BATTERY WAITING TO CHARGE OU VERY LOW BATTERY WAITING TO CHARGE OU HOT CHARGER WAITING TO CHARGE	Âmbar Piscando 

## Armazenamento de Longo Prazo de Baterias IMPRES 2 ou IMPRES

Você pode preparar baterias IMPRES 2 ou IMPRES independentes originais da Motorola Solutions (Íon de Lítio ou Níquel) para Armazenamento de Longo Prazo em um local adequado para armazenamento, usando um Carregador para Várias Unidades IMPRES 2. Outros tipos de bateria estão com falha. Se a bateria IMPRES 2 estiver equipada com um modo de Suspensão, o carregador colocará a bateria em repouso após a conclusão do carregamento para Armazenamento de Longo Prazo.

Prepare apenas baterias IMPRES 2 ou IMPRES para Armazenamento de Longo Prazo. Remova a bateria do rádio antes de colocá-la no carregador.

NÃO armazene uma bateria independente no carregador. Depois que o preparo para Armazenamento de Longo Prazo estiver concluído, remova imediatamente a bateria autônoma do carregador.

A seleção do Armazenamento de Longo Prazo sobrepõe a Calibração/Recondicionamento. Baterias de lítio preparadas para Armazenamento de Longo Prazo podem não atender às regulamentações para remessa por carga aérea.

**Tabela 13:** Indicações de Armazenamento de Longo Prazo de uma Bateria IMPRES 2 ou IMPRES – Bateria precisa de Calibração

Status	Visor do Carregador	Indicador de LED
Carregador Ligado	IMPRES 2 CHARGER	Verde por aproximadamente um segundo 
Bateria Detectada	IMPRES 2 BATTERY ou IMPRES BATTERY	Bateria requer Calibração: Alternando entre Âmbar/ Verde por 4 segundos  
Descarregamento da Bateria	STORAGE DISCHARGE xxxx% Rated Cap	Âmbar Contínuo 
Carregamento Rápido	STORAGE CHARGE xxx% Rated Cap	Vermelho Constante 

**Tabela 13:** Indicações de Armazenamento de Longo Prazo de uma Bateria IMPRES 2 ou IMPRES – Bateria precisa de Calibração (Continuação)

Armazenamento de Longo Prazo Concluído	LONGTERM STORAGE xxx% Rated Cap	Alternando Âmbar/Verde 
<p>Falha</p> <ul style="list-style-type: none"> <li>• A bateria não está fazendo o contato elétrico adequado com o carregador.</li> <li>• A bateria não é IMPRES 2 ou IMPRES.</li> <li>• Uma condição desconhecida está impedindo que a bateria seja descarregada.</li> <li>• O carregamento foi concluído antes que a meta de Armazenamento de Longo Prazo pudesse ser atingida.</li> <li>• O compartimento do carregador é um tipo especial.</li> </ul>	<p>AVISO:</p> <p>NOT CHARGEABLE REMOVE&amp; REINSERT OU WRONG BATT TYPE CANNOT LT STORE OU CANNOT DISCHARGE FOR LT STORAGE OU STORE INCOMPLETE Low Capacity:yy% OU RADIO POCKET CANNOT LT STORE OU CHARGING POCKET CANNOT LT STORE</p>	<p>Vermelho Piscando </p>
<p>Standby</p> <ul style="list-style-type: none"> <li>• A bateria está aguardando carregamento rápido.</li> <li>• A bateria está muito quente, muito fria ou com baixa tensão.</li> <li>• O carregador está muito quente.</li> </ul>	<p>AVISO:</p> <p>HOT BATTERY WAITING TO CHRGE OU COLD BATTERY WAITING TO CHRGE OU VERY LOW BATTERY WAITING TO CHRGE OU HOT CHARGER WAITING TO CHRGE</p>	<p>Âmbar Piscando </p>

**Nota:**

- As mensagens a seguir foram introduzidas na versão V1.05 do software:
  - Cannot Discharge, for LT Storage
  - Store Incomplete, Low Capacity:yy%
  - Hot Charger, Waiting to Chrge

- As mensagens a seguir foram introduzidas na versão V1.11.01 do software:

- Wrong Batt Type, Cannot LT Store
- Radio Pocket, Cannot LT Store
- Charging Pocket, Cannot LT Store

**Tabela 14:** Indicações de Armazenamento de Longo Prazo de uma Bateria IMPRES 2 ou IMPRES – Bateria Calibrada, Deve Carregar até a Seleção

Status	Visor do Carregador	Indicador de LED
Carregador Ligado	IMPRES 2 CHARGER	Verde por aproximadamente um segundo 
Bateria Detectada	IMPRES 2 BATTERY ou IMPRES BATTERY	Vermelho Constante 
Carregamento Rápido	STORAGE CHARGE xxx% Rated Cap	Vermelho Constante 
Armazenamento de Longo Prazo Concluído	LONGTERM STORAGE xxx% Rated Cap	Verde Constante 
Falha <ul style="list-style-type: none"> <li>• A bateria não está fazendo o contato elétrico adequado com o carregador.</li> <li>• A bateria não é IMPRES 2 ou IMPRES.</li> <li>• Uma condição desconhecida está impedindo que a bateria seja descarregada.</li> <li>• O carregamento foi concluído antes que a meta de Armazenamento de Longo Prazo pudesse ser atingida.</li> <li>• O compartimento do carregador é um tipo especial.</li> </ul>	AVISO: NOT CHARGEABLE REMOVE& REINSERT OU WRONG BATT TYPE CANNOT LT STORE OU CANNOT DISCHARGE FOR LT STORAGE OU STORE INCOMPLETE Low Capacity:yy% OU RADIO POCKET CANNOT LT STORE OU CHARGING POCKET CANNOT LT STORE	Vermelho Piscando 

**Tabela 14:** Indicações de Armazenamento de Longo Prazo de uma Bateria IMPRES 2 ou IMPRES – Bateria Calibrada, Deve Carregar até a Seleção (Continuação)

Status	Visor do Carregador	Indicador de LED
Standby <ul style="list-style-type: none"> <li>• A bateria está aguardando carregamento rápido.</li> <li>• A bateria está muito quente, muito fria ou com baixa tensão.</li> <li>• O carregador está muito quente.</li> </ul>	AVISO: HOT BATTERY WAITING TO CHARGE OU COLD BATTERY WAITING TO CHARGE OU VERY LOW BATTERY WAITING TO CHARGE OU HOT CHARGER WAITING TO CHARGE	Âmbar Piscando 

**Tabela 15:** Indicações de Armazenamento de Longo Prazo de uma Bateria IMPRES 2 ou IMPRES – Bateria Calibrada, Deve Descarregar até a Seleção

Status	Visor do Carregador	Indicador de LED
Carregador Ligado	IMPRES 2 CHARGER	Verde por aproximadamente um segundo 
Bateria Detectada	IMPRES 2 BATTERY ou IMPRES BATTERY	Âmbar Contínuo 
Descarregamento da Bateria	STORAGE DISCHARGE xxx% Rated Cap	Âmbar Contínuo 
Armazenamento de Longo Prazo Concluído	LONGTERM STORAGE xxx% Rated Cap	Verde Constante 

**Tabela 15:** Indicações de Armazenamento de Longo Prazo de uma Bateria IMPRES 2 ou IMPRES – Bateria Calibrada, Deve Descarregar até a Seleção (Continuação)

Status	Visor do Carregador	Indicador de LED
<p>Falha</p> <ul style="list-style-type: none"> <li>A bateria não está fazendo o contato elétrico adequado com o carregador.</li> <li>A bateria não é IMPRES 2 ou IMPRES.</li> <li>Uma condição desconhecida está impedindo que a bateria seja descarregada.</li> <li>O carregamento foi concluído antes que a meta de Armazenamento de Longo Prazo pudesse ser atingida.</li> <li>O compartimento do carregador é um tipo especial.</li> </ul>	<p>AVISO:</p> <p>NOT CHARGEABLE REMOVE&amp; REINSERT OU</p> <p>WRONG BATT TYPE CANNOT LT STORE OU</p> <p>CANNOT DISCHARGE FOR LT STORAGE OU</p> <p>STORE INCOMPLETE Low Capacity:yy% OU</p> <p>RADIO POCKET CANNOT LT STORE OU</p> <p>CHARGING POCKET CANNOT LT STORE</p>	<p>Vermelho Piscando</p> 
<p>Standby</p> <ul style="list-style-type: none"> <li>A bateria está aguardando carregamento rápido.</li> <li>A bateria está muito quente, muito fria ou com baixa tensão.</li> <li>O carregador está muito quente.</li> </ul>	<p>AVISO:</p> <p>HOT BATTERY WAITING TO CHRGE OU</p> <p>COLD BATTERY WAITING TO CHRGE OU</p> <p>VERY LOW BATTERY WAITING TO CHRGE OU</p> <p>VERY LOW BATTERY WAITING TO CHRGE</p>	<p>Âmbar Piscando</p> 

## Preparação para Remessa de Bateria de Íon de Lítio

Você pode preparar baterias independentes IMPRES 2, IMPRES ou outras baterias originais de Íon de Lítio da Motorola Solutions para remessa por carga área usando um Carregador para Várias Unidades IMPRES 2. Outros tipos de bateria estão com falha. Se a bateria de Íon de Lítio IMPRES 2 estiver equipada com um modo de Suspensão, o carregador colocará a bateria em repouso após a conclusão do carregamento para Remessa de Lítio.

Prepare para remessa apenas baterias independentes de Íon de Lítio da Motorola Solutions. Remova a bateria do rádio antes de colocá-la no carregador.

NÃO armazene uma bateria independente no carregador. Depois que o preparo para Remessa de Lítio estiver concluído, remova imediatamente a bateria autônoma do carregador.

A seleção de Remessa de Lítio substitui a Calibração/Recondicionamento.

### Bateria IMPRES 2 ou IMPRES

**Tabela 16:** Indicações de Status de uma Bateria de Íon de Lítio Preparada para Remessa – Bateria IMPRES 2 ou IMPRES precisa de Calibração

Status	Visor do Carregador	Indicador de LED
Carregador Ligado	IMPRES 2 CHARGER	Verde por aproximadamente um segundo 
Bateria Detectada	IMPRES 2 BATTERY ou IMPRES BATTERY	Bateria requer Calibração: Alternando entre Âmbar/ Verde por 4 segundos 
Descarregamento da Bateria	SHIP LI DISCHARGE xxx% Rated Cap	Âmbar Contínuo 
Carregamento Rápido	SHIP LI CHARGE xxx% Rated Cap	Vermelho Constante 
Remessa de Lítio Concluída	LI READY TO SHIP xxx% Rated Cap	Alternando Âmbar/Verde 

**Tabela 16:** Indicações de Status de uma Bateria de Íon de Lítio Preparada para Remessa – Bateria IMPRES 2 ou IMPRES precisa de Calibração (Continuação)

Status	Visor do Carregador	Indicador de LED
<p>Falha</p> <ul style="list-style-type: none"> <li>A bateria não está fazendo o contato elétrico adequado com o carregador.</li> <li>A bateria é Desconhecida ou Níquel.</li> <li>Uma condição desconhecida está impedindo que a bateria seja descarregada.</li> <li>O carregamento foi concluído antes que a meta de Remessa de Lítio pudesse ser atingida.</li> <li>O compartimento do carregador é um tipo especial.</li> </ul>	<p>AVISO:</p> <p>NOT CHARGEABLE REMOVE&amp; REINSERT OU</p> <p>WRONG BATT TYPE CANNOT SHIP LI OU</p> <p>CANNOT DISCHARGE FOR LI SHIPMENT OU</p> <p>SHIP INCOMPLETE Low Capacity:yy%</p> <p>OU</p> <p>RADIO POCKET CANNOT SHIP LI OU</p> <p>CHARGING POCKET CANNOT SHIP LI</p>	<p>Vermelho Piscando</p> 
<p>Standby</p> <ul style="list-style-type: none"> <li>A bateria está aguardando carregamento rápido.</li> <li>A bateria está muito quente, muito fria ou com baixa tensão.</li> <li>O carregador está muito quente.</li> </ul>	<p>AVISO:</p> <p>HOT BATTERY WAITING TO CHRGE OU</p> <p>COLD BATTERY WAITING TO CHRGE OU</p> <p>VERY LOW BATTERY WAITING TO CHRGE OU</p> <p>HOT CHARGER WAITING TO CHRGE</p>	<p>Âmbar Piscando</p> 

**Nota:**

- As mensagens a seguir foram introduzidas na versão V1.05 do software:
  - Ship LI Discharge, xxx% Rated Capacity
  - Ship LI Charge, xxx% Rated Capacity
  - LI Ready to Ship, xx% Rated Capacity
  - Cannot Discharge, for LI Shipment
  - Ship Incomplete, Low Capacity:yy%



- As mensagens a seguir foram introduzidas na versão V1.11.01 do software:
  - Wrong Batt Type, Cannot Ship LI
  - Radio Pocket, Cannot Ship LI
  - Charging Pocket, Cannot Ship LI

**Tabela 17:** Indicações de Status de uma Bateria de Íon de Lítio Preparada para Remessa – Bateria IMPRES 2 ou IMPRES Calibrada, Precisa Carregar

Status	Visor do Carregador	Indicador de LED
Carregador Ligado	IMPRES 2 CHARGER	Verde por aproximadamente um segundo 
Bateria Detectada	IMPRES 2 BATTERY ou IMPRES BATTERY	Vermelho Constante 
Carregamento Rápido	SHIP LI CHARGE xxx% Rated Cap	Vermelho Constante 
Remessa de Lítio Concluída	LI READY TO SHIP xxx% Rated Cap	Verde Constante 
<b>Falha</b> <ul style="list-style-type: none"> <li>• A bateria não está fazendo o contato elétrico adequado com o carregador.</li> <li>• Bateria é Desconhecida ou de Níquel</li> <li>• Uma condição desconhecida está impedindo que a bateria seja descarregada.</li> <li>• O carregamento foi concluído antes que a meta de Remessa de Lítio pudesse ser atingida.</li> <li>• O compartimento do carregador é um tipo especial.</li> </ul>	AVISO: NOT CHARGEABLE REMOVE& REINSERT OU WRONG BATT TYPE CANNOT SHIP LI OU CANNOT DISCHARGE FOR LI SHIPMENT OU SHIP INCOMPLETE Low Capacity:yy% OU RADIO POCKET CANNOT SHIP LI OU CHARGING POCKET CANNOT SHIP LI	Vermelho Piscando 

**Tabela 17:** Indicações de Status de uma Bateria de Íon de Lítio Preparada para Remessa – Bateria IMPRES 2 ou IMPRES Calibrada, Precisa Carregar (Continuação)

Status	Visor do Carregador	Indicador de LED
<p>Standby</p> <ul style="list-style-type: none"> <li>A bateria está aguardando carregamento rápido.</li> <li>A bateria está muito quente, muito fria ou com baixa tensão.</li> <li>O carregador está muito quente.</li> </ul>	<p>AVISO:</p> <p>HOT BATTERY WAITING TO CHARGE OU COLD BATTERY WAITING TO CHARGE OU VERY LOW BATTERY WAITING TO CHARGE OU HOT CHARGER WAITING TO CHARGE</p>	<p>Âmbar Piscando</p> 

**Tabela 18:** Indicações de Status de uma Bateria de Íon de Lítio Preparada para Remessa – Bateria IMPRES 2 ou IMPRES Calibrada, Precisa Descarregar

Status	Visor do Carregador	Indicador de LED
Carregador Ligado	IMPRES 2 CHARGER	Verde por aproximadamente um segundo 
Bateria Detectada	IMPRES 2 BATTERY ou IMPRES BATTERY	Âmbar Contínuo 
Descarregamento da Bateria	SHIP LI DISCHARGE xxx% Rated Cap	Âmbar Contínuo 
Remessa de Lítio Concluída	LI READY TO SHIP xxx% Rated Cap	Verde Constante 

**Tabela 18:** Indicações de Status de uma Bateria de Íon de Lítio Preparada para Remessa – Bateria IMPRES 2 ou IMPRES Calibrada, Precisa Descarregar (Continuação)

Status	Visor do Carregador	Indicador de LED
<p>Falha</p> <ul style="list-style-type: none"> <li>• A bateria não está fazendo o contato elétrico adequado com o carregador.</li> <li>• Bateria é Desconhecida ou de Níquel</li> <li>• Uma condição desconhecida está impedindo que a bateria seja descarregada.</li> <li>• O carregamento foi concluído antes que a meta de Remessa de Lítio pudesse ser atingida.</li> <li>• O compartimento do carregador é um tipo especial.</li> </ul>	<p>AVISO:</p> <p>NOT CHARGEABLE REMOVE&amp; REINSERT OU</p> <p>WRONG BATT TYPE CANNOT SHIP LI OU</p> <p>CANNOT DISCHARGE FOR LI SHIPMENT OU</p> <p>SHIP INCOMPLETE Low Capacity:yy% OU</p> <p>RADIO POCKET CANNOT SHIP LI OU</p> <p>CHARGING POCKET CANNOT SHIP LI</p>	<p>Vermelho Piscando</p> 
<p>Standby</p> <ul style="list-style-type: none"> <li>• A bateria está aguardando carregamento rápido.</li> <li>• A bateria está muito quente, muito fria ou com baixa tensão.</li> <li>• O carregador está muito quente.</li> </ul>	<p>AVISO:</p> <p>HOT BATTERY WAITING TO CHRGE OU</p> <p>COLD BATTERY WAITING TO CHRGE OU</p> <p>VERY LOW BATTERY WAITING TO CHRGE OU</p> <p>HOT CHARGER WAITING TO CHRGE</p>	<p>Âmbar Piscando</p> 

## Outras Baterias da Motorola Solutions

**Tabela 19:** Indicações de Status de uma Bateria de Íon de Lítio Preparada para Remessa – Outras Baterias da Motorola Solutions

Status	Visor do Carregador	Indicador de LED
Carregador Ligado	IMPRES 2 CHARGER	Verde por aproximadamente um segundo 
Bateria Detectada	MOTOROLA SOLUTHS BATTERY	Âmbar Contínuo 
Descarregamento da Bateria	SHIP LI DISCHARGE xxx% Rated Cap	Âmbar Contínuo 
Carregamento Rápido	SHIP LI CHARGE xxx% Rated Cap	Vermelho Constante 
Remessa de Lítio Concluída	LI READY TO SHIP xxx% Rated Cap	Verde Constante 
<p>Falha</p> <ul style="list-style-type: none"> <li>A bateria não está fazendo o contato elétrico adequado com o carregador.</li> <li>Bateria é Desconhecida ou de Níquel</li> <li>Uma condição desconhecida está impedindo que a bateria seja descarregada.</li> <li>O carregamento foi concluído antes que a meta de Remessa de Lítio pudesse ser atingida.</li> <li>O compartimento do carregador é um tipo especial.</li> </ul>	<p>AVISO:</p> <p>NOT CHARGEABLE REMOVE&amp; REINSERT OU WRONG BATT TYPE CANNOT SHIP LI OU CANNOT DISCHARGE FOR LI SHIPMENT OU SHIP INCOMPLETE Low Capacity:yy% OU RADIO POCKET CANNOT SHIP LI OU CHARGING POCKET CANNOT SHIP LI</p>	<p>Vermelho Piscando </p>

**Tabela 19:** Indicações de Status de uma Bateria de Íon de Lítio Preparada para Remessa – Outras Baterias da Motorola Solutions (Continuação)

Status	Visor do Carregador	Indicador de LED
Standby <ul style="list-style-type: none"> <li>• A bateria está aguardando carregamento rápido.</li> <li>• A bateria está muito quente, muito fria ou com baixa tensão.</li> <li>• O carregador está muito quente.</li> </ul>	AVISO: HOT BATTERY WAITING TO CHARGE OU COLD BATTERY WAITING TO CHARGE OU VERY LOW BATTERY WAITING TO CHARGE OU HOT CHARGER WAITING TO CHARGE	Âmbar Piscando 

## Menu de Configuração do Carregador



Desocupe todos os compartimentos do carregador antes de entrar na configuração do carregador.

O teclado do carregador está localizado abaixo do visor do Compartimento nº 1.

Para acessar a Charger Setup, mantenha pressionados os botões de Seta para a Esquerda e para a Direita por mais do que a seleção do Tempo de Entrada (3 segundos, padrão).

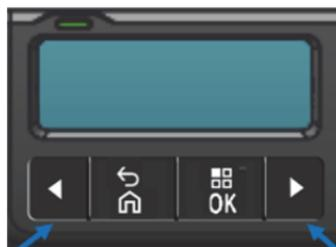

Seta para esquerda

Seta para direita

**Figura 4:** Botões de Exibição do Menu para Acessar o Modo de Configuração

## Menu Principal

Depois de acessar a Configuração do Carregador, a seguinte mensagem é exibida:

Press OK to entr  
SETUP MENU

Pressionar OK solicita a exibição do Setup Menu do Carregador disponível.



Figura 5: Menu de Configuração do Carregador

## Seleção do Menu de Configuração do Carregador

Em cada seleção do Menu de Configuração:

- Para percorrer as seleções de menu, pressione a Seta para Direita.
- Para percorrer as seleções de menu na ordem inversa, pressione a Seta para a Esquerda.
- Para acessar o menu selecionado ou selecionar a opção desejada, pressione OK.

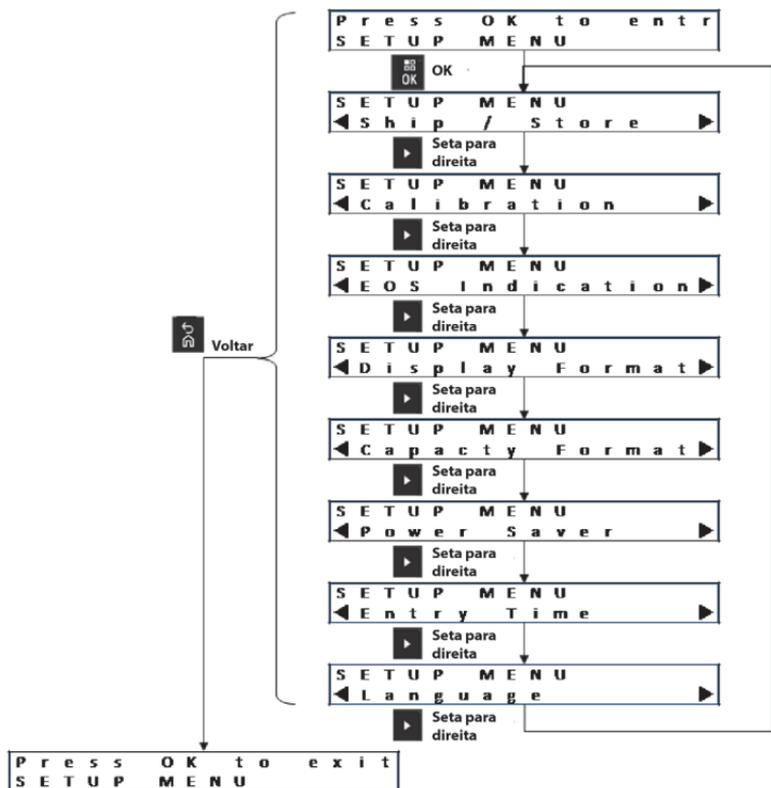
**Nota:** a marca de seleção identifica a opção selecionada no momento.

Lançado na versão V1.11.01, pressione OK para exibir o próximo compartimento no visor do Compartimento nº 1.

- Para sair do menu selecionado, pressione Voltar e pressione OK para confirmar a saída.

Se nenhum botão do Teclado for pressionado em até 10 minutos, o carregador sairá da Configuração do Carregador e retornará às exibições normais de mensagens.

As seleções de Configuração do Carregador são armazenadas em uma memória não volátil. As seleções não são afetadas pelos ciclos de alimentação do carregador.

## Menu de Remessa ou Armazenamento

Há quatro opções de Remessa/Armazenamento:

- Desativado
- Remessa de Íon de Lítio
- Armazenamento de Longo Prazo
- Armazenamento de Longo Prazo a 75% da Capacidade Nominal

As seleções de Íon de Lítio, Armazenamento a Longo Prazo e Armazenamento a Longo Prazo a 75% substituem a configuração da Calibração.





## Armazenamento de Longo Prazo

O Armazenamento de Longo Prazo define a bateria IMPRES 2 ou IMPRES para um Estado de Carga adequado para colocar a bateria em armazenamento durante um longo período. Geralmente, o armazenamento preferencial do Estado da Carga é significativamente menor do que a carga completa. A seleção  $xx\%$  é um valor programado na bateria IMPRES 2 ou IMPRES ou, por padrão, 50% da capacidade nominal. O Armazenamento de Longo Prazo a 75% da Capacidade Nominal está disponível para situações que exigem que a bateria armazenada tenha um Estado de Carga maior, a fim de minimizar o tempo de carga completa se a bateria precisar ser colocada em serviço rapidamente ou para permitir armazenamento por um período mais longo.

Algumas baterias IMPRES 2 ou IMPRES podem ser totalmente descarregadas antes do carregamento para seleção de Armazenamento de Longo Prazo. Essas baterias são IMPRES 2 ou IMPRES que nunca foram calibradas ou que precisam de uma nova calibração.

O Armazenamento de Longo Prazo é aplicável apenas a baterias IMPRES 2 ou IMPRES. Outras baterias (como baterias Desconhecidas, não IMPRES ou Compartimento da Motorola Solutions) falharão.



## Menu de Indicação do LED de Fim de Vida Útil

Ainda que a bateria IMPRES ou IMPRES 2 esteja no Fim da Vida Útil, sua capacidade pode ser suficiente para uso leve. Como resultado, pode ser desejável desabilitar a indicação de LED do Fim de Vida Útil (**Vermelho/Verde Intermitente**).

Para a bateria APX NEXT XN, desabilitar esta indicação também desabilita a indicação de bateria exposta a superaquecimento cumulativo.



Figura 8: Menu de Indicação do LED de Fim de Vida Útil

## Menu de Formato de Visualização

Há quatro opções de Formato de Visualização:

- Orientação normal (carregador em uma mesa de trabalho).
- Orientação invertida (carregador pendurado em uma parede).
- Somente mensagens de aviso. Outras mensagens não são exibidas. Isso se aplica às orientações Normal e Invertida. Mensagens de aviso são identificadas na Tabela 6 por meio da Tabela 12.
- Visor desligado durante a operação Normal. O visor está sempre ativado no Modo de Configuração e no Modo Analisador.

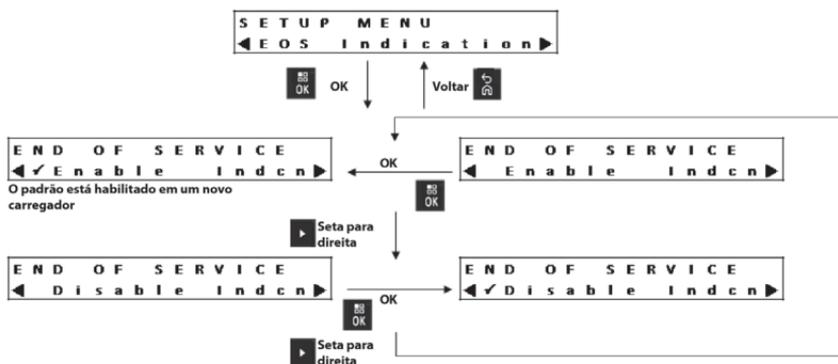

Figura 9: Menu de Formato de Visualização

## Menu de Formato de Capacidade

A Capacidade da Bateria é exibida em um dos vários formatos disponíveis. Se a Capacidade da Bateria for exibida como uma porcentagem, a porcentagem fará referência à Capacidade Potencial (carga completa) ou Capacidade Nominal. Normalmente, os rádios IMPRES mostram a porcentagem de Capacidade da Bateria com referência à Capacidade Potencial.

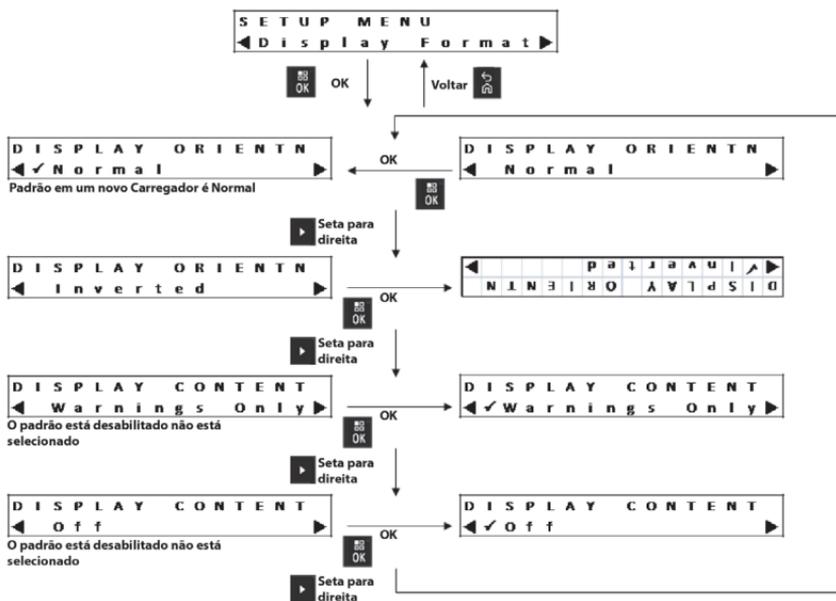

Figura 10: Menu de Formato de Capacidade

**Tabela 20:** Opções de Exibição de Capacidade da Bateria

Representação	Descrição
xxx0mAh	Carga Atual (Estado da Carga) em miliampéres horas.
yyy%	Carga Atual em relação à Capacidade Potencial ou Capacidade Nominal em porcentagem. Quando referente à Capacidade Potencial, o valor máximo é 100%. Quando referente à Capacidade Nominal, o valor máximo pode ser superior a 100%, especialmente para uma nova bateria.
%BAR	O equivalente de yyy% é representado em uma barra de oito segmentos.

## Menu de Economia de Energia

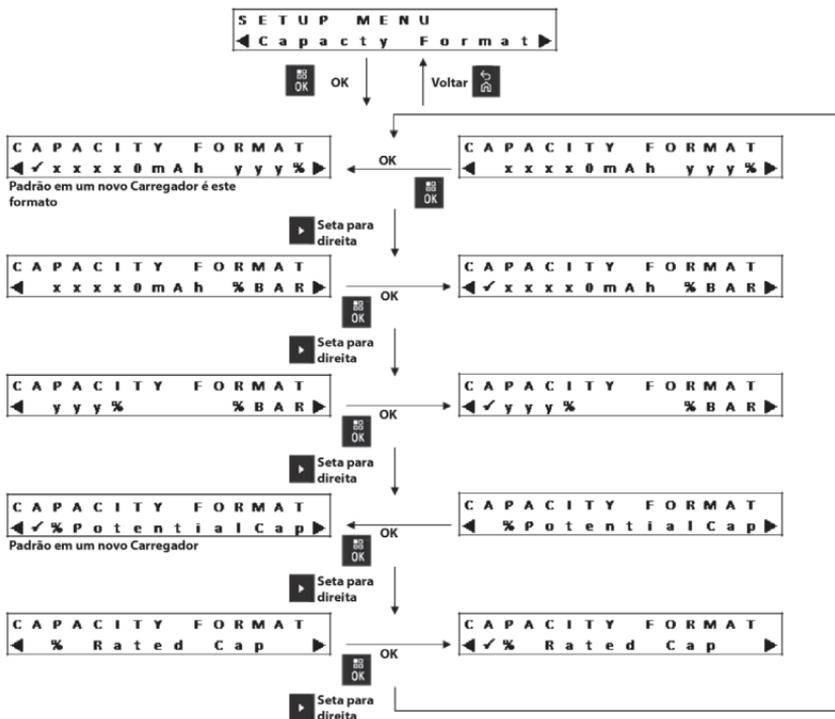
Para atender a certos limites governamentais de baixo consumo de energia em modo de espera, o modo de Economia de Energia permite que o carregador desligue todos os compartimentos, exceto o Compartimento nº 1, quando não houver atividade nesses compartimentos durante algum período de tempo. Os exemplos de atividade incluem o seguinte:

- Carregamento de rádio ou bateria.
- Calibração/Recondicionamento da Bateria.
- Preparo de bateria original de Íon de Lítio da Motorola Solutions para remessa
- Preparo de bateria IMPRES 2 ou IMPRES para Armazenamento de Longo Prazo.
- Modo de Configuração do Carregador ou Modo de Análise.
- Reprogramação do Carregador.
- Comunicação com o Sistema de Gerenciamento de Frota da Bateria IMPRES
- Qualquer indicação de LED piscando.

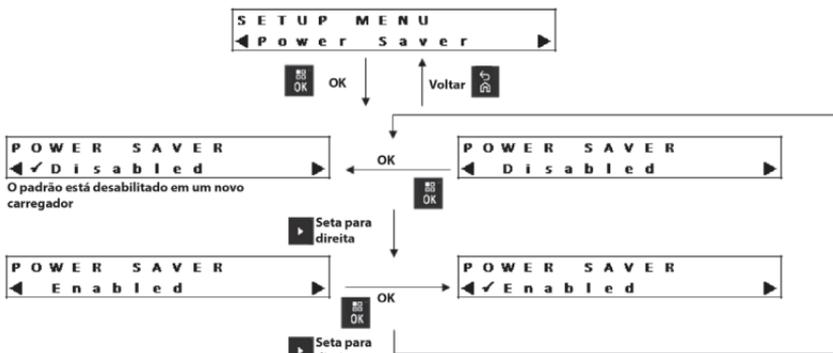

**Figura 11:** Menu de Economia de Energia

O Compartimento 1 permanece ligado, mas pode estar no modo suspenso. Para ativar os outros compartimentos, pressione qualquer botão do teclado. Até que os outros compartimentos sejam ligados, eles não poderão responder à inserção ou remoção da bateria ou do rádio.

## Menu de Tempo de Entrada

O Tempo de Entrada de pressionamento do botão necessário para entrar no modo de Configuração do Carregador ou no modo Analisador do Carregador.



Figura 12: Menu de Tempo de Entrada



## Menu de Idioma

Atualmente, o carregador exibe suporte em um idioma: Inglês Norte-Americano.

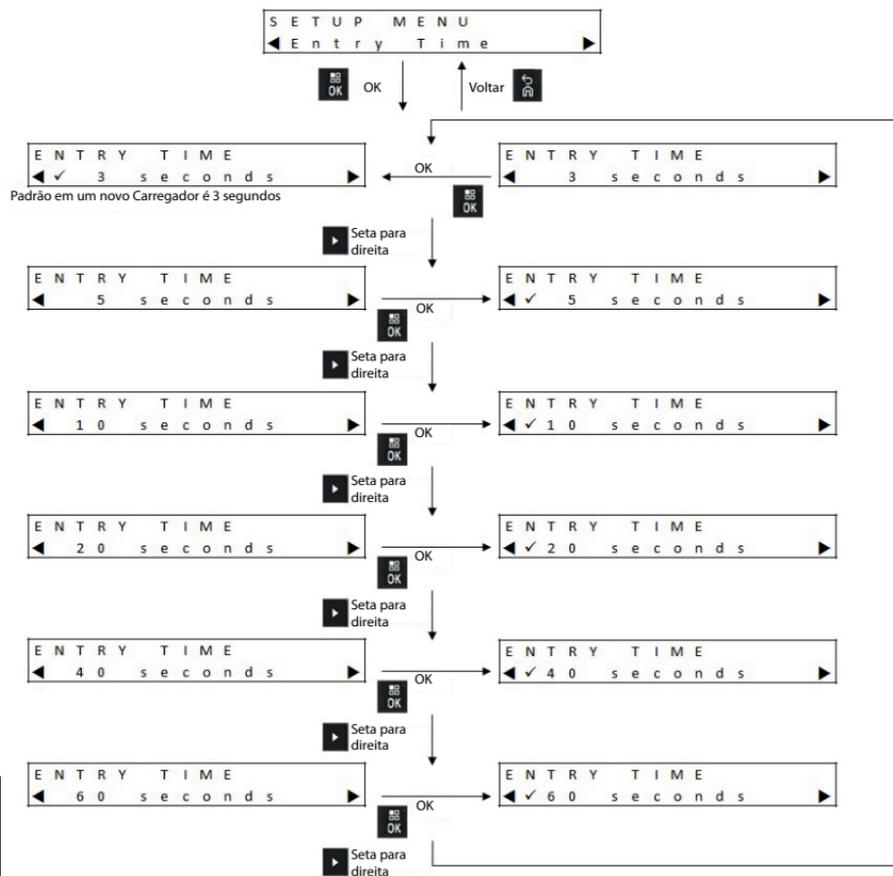
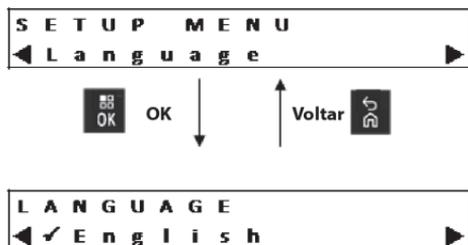

**Figura 13:** Menu de Idioma

## Modo Analisador

O teclado do carregador está localizado abaixo do visor do Compartimento nº 1.

Para entrar no Modo Analisador, mantenha pressionado o botão OK por mais do que a seleção do Tempo de Entrada (3 segundos, padrão).



**Figura 14:** Botão de Exibição do Menu para Acessar o Modo Analisador  
Depois de acessar o Modo Analisador, a seguinte mensagem é exibida:

Press OK to entr  
ANALYZER MODE

Pressionar OK solicita a exibição das informações de bateria disponível.

## Modo Analisador versão V1.0

Na versão do software V1.0, o Modo Analisador é limitado ao Compartimento nº 1. As informações do analisador em relação ao Compartimento nº 1 e seu conteúdo são apresentadas no visor do Compartimento nº 1. Se nenhum botão do teclado for pressionado em até 10 minutos, o carregador sairá do Modo Analisador e retornará às exibições normais de mensagens.



Figura 15: Menu do Modo Analisador versão V1.0

## Modo Analisador versão V1.05

O Modo Analisador foi aprimorado com o lançamento da versão V1.05 do software. Para carregadores com um visor em cada compartimento, as informações do Analisador são exibidas no visor adjacente ao compartimento. Ao percorrer as informações do Analisador no Compartimento nº1, outros visores percorrem pelas informações do Analisador disponíveis para o compartimento adjacente.

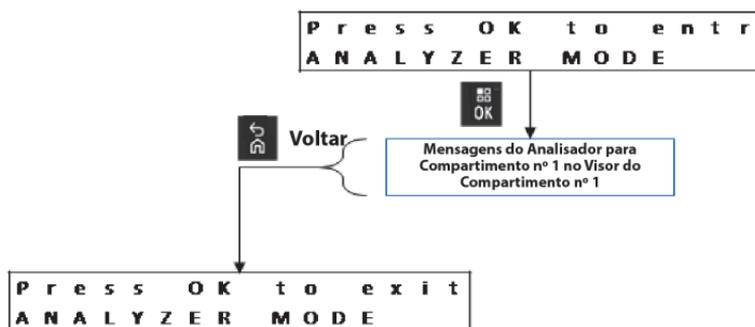
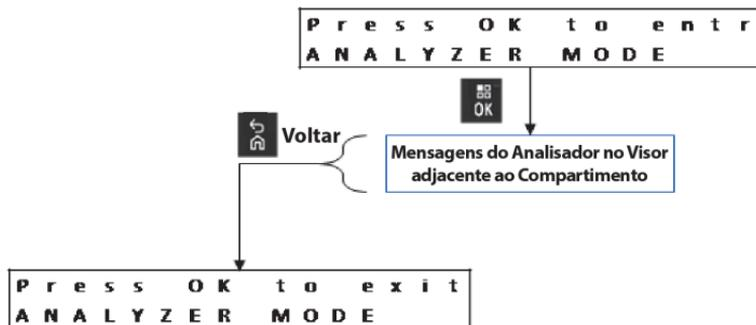

**Figura 16:** Menu do Modo Analisador versão V1.05

## Modo Analisador versão V1.11.01

O Modo Analisador foi aprimorado, novamente, com o lançamento da versão V1.11.01 do software. Para carregadores com um visor apenas no Compartimento nº 1, o Visor de Menu do Compartimento nº 1 pode ser usado para exibir informações sobre qualquer outro compartimento do carregador. O aprimoramento da versão V1.05 permanece.

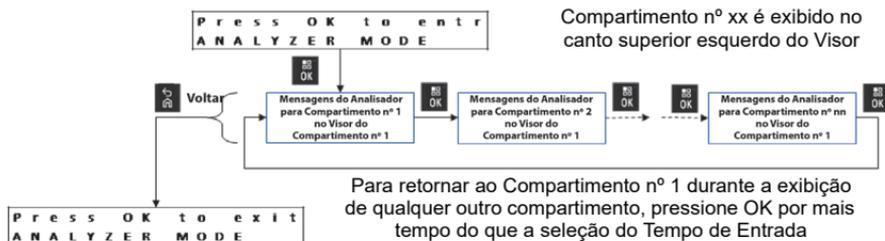

**Figura 17:** Menu do Modo Analisador versão V1.11.01

## Trocar Baterias em um Compartimento

Se a bateria for removida e, em seguida, a mesma ou outra bateria for inserida no mesmo compartimento, o parâmetro exibido para a segunda bateria é o mesmo parâmetro que estava sendo exibido para a primeira bateria.

Por exemplo, a mensagem `Battery IMPRES Cycles` está sendo exibida para uma bateria IMPRES 2 ou IMPRES. Essa bateria é removida do compartimento. Outra bateria IMPRES 2 ou IMPRES é inserida no mesmo compartimento. O primeiro parâmetro exibido para a segunda bateria mostra `Battery IMPRES Cycles`.

No entanto, a segunda bateria pode não ter o parâmetro exibido pela primeira bateria. Nesse caso, a mensagem de identificação é exibida para a segunda bateria.

# Bateria IMPRES 2

## Tela Adjacente ao Compartimento



Figura 18: Menu do Modo Analisador da Bateria IMPRES 2 para Visor Adjacente ao Compartimento

# Compartimento nº 1 Exibindo outro Compartimento

Compartimento nº xx é exibido no canto superior esquerdo do Visor

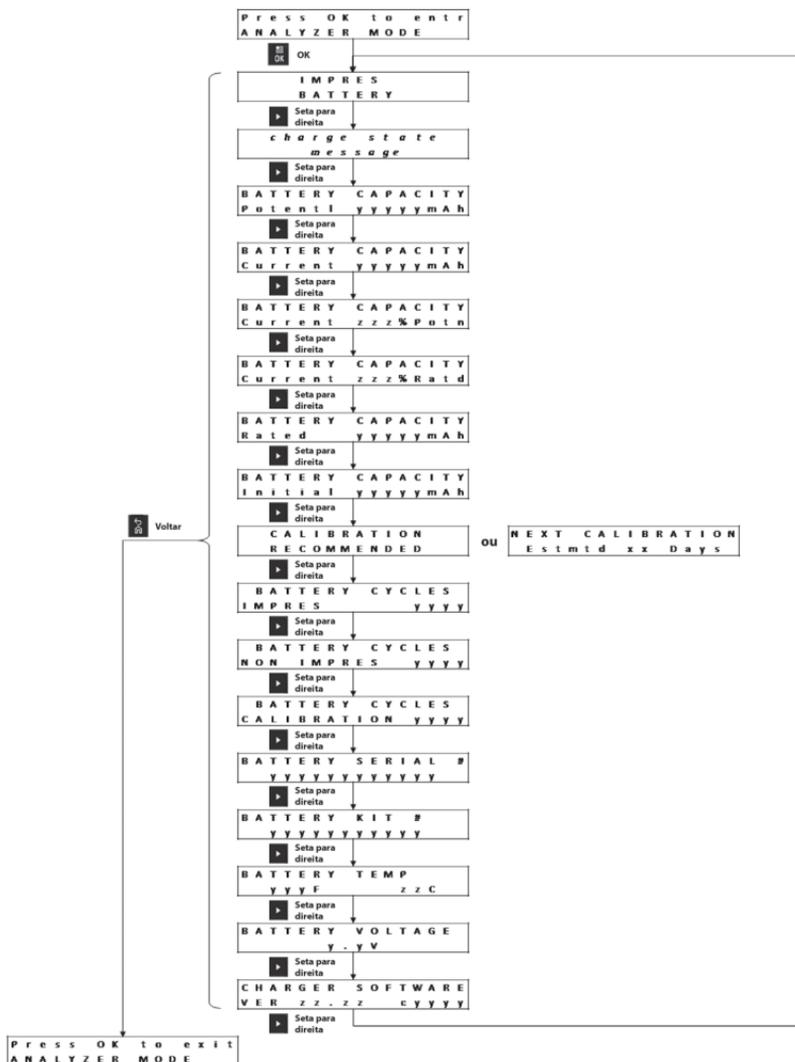

Figura 19: Menu do Modo Analisador da Bateria IMPRES 2 para Outro Compartimento (que não o Compartimento nº 1)

# Bateria IMPRES

## Tela Adjacente ao Compartimento

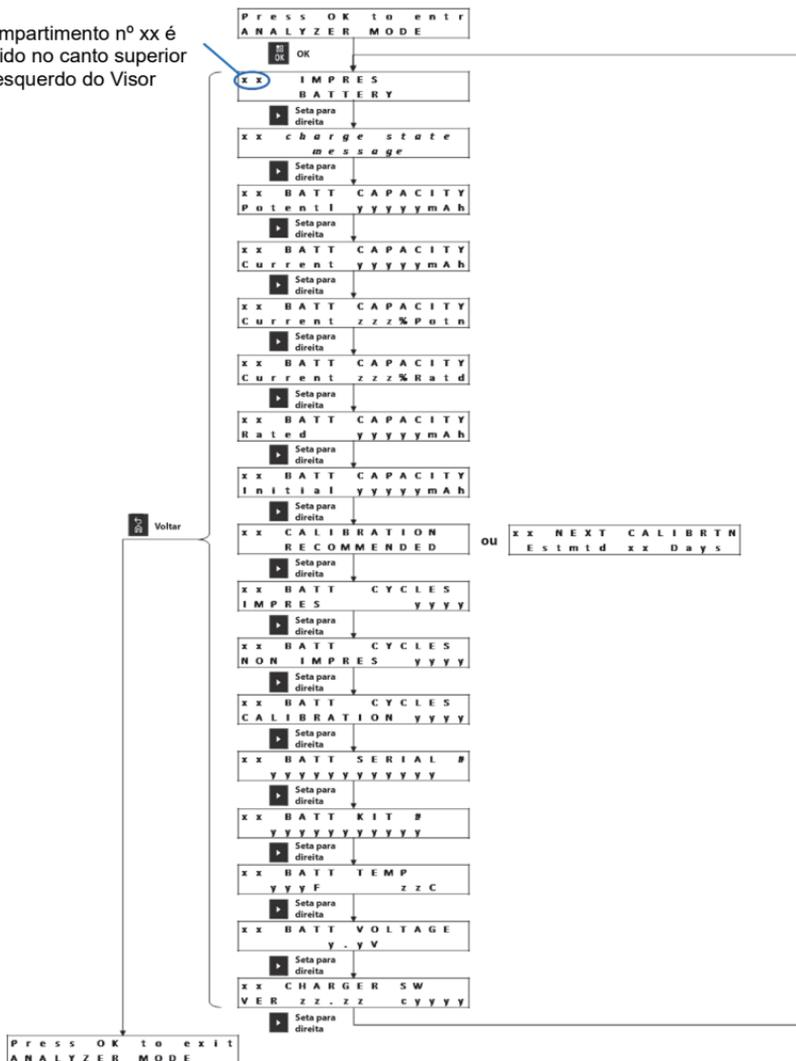

Figura 20: Menu do Modo Analisador da Bateria IMPRES para Visor Adjacente ao Compartimento

# Compartimento nº 1 Exibindo outro Compartimento

Compartimento nº xx é exibido no canto superior esquerdo do Visor

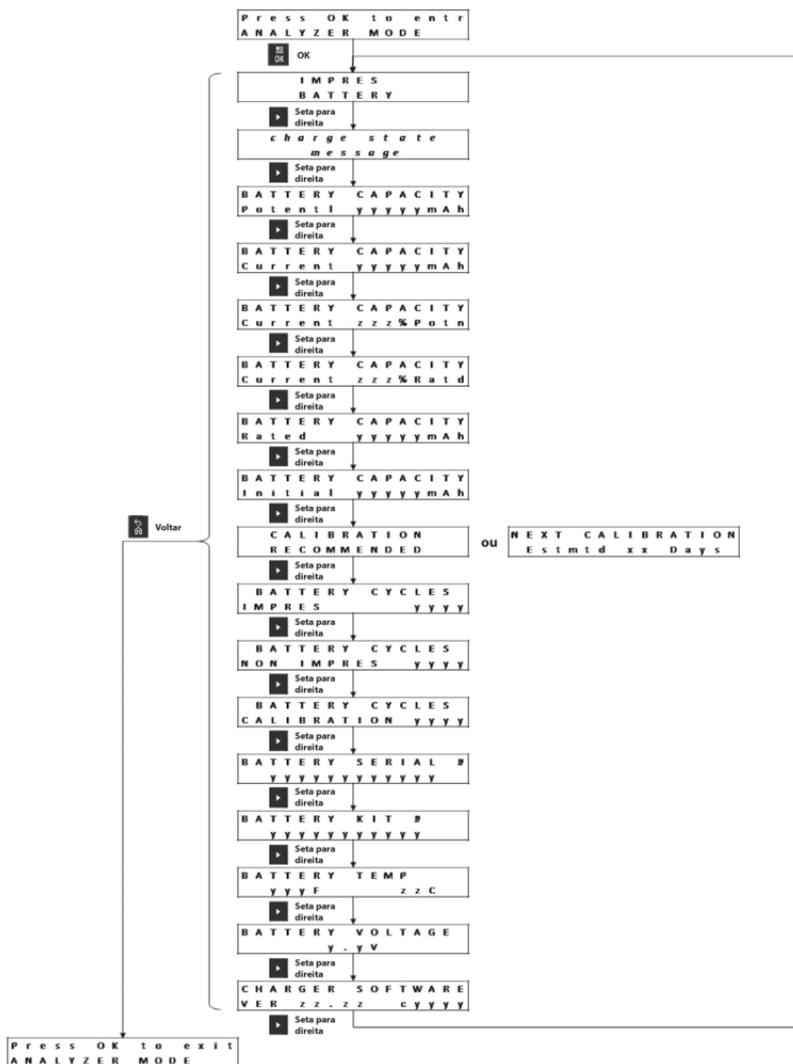

Figura 21: Menu do Modo Analisador da Bateria IMPRES para Outro Compartimento (que não o Compartimento nº 1)



# Outras Baterias da Motorola Solutions

## Tela Adjacente ao Compartimento

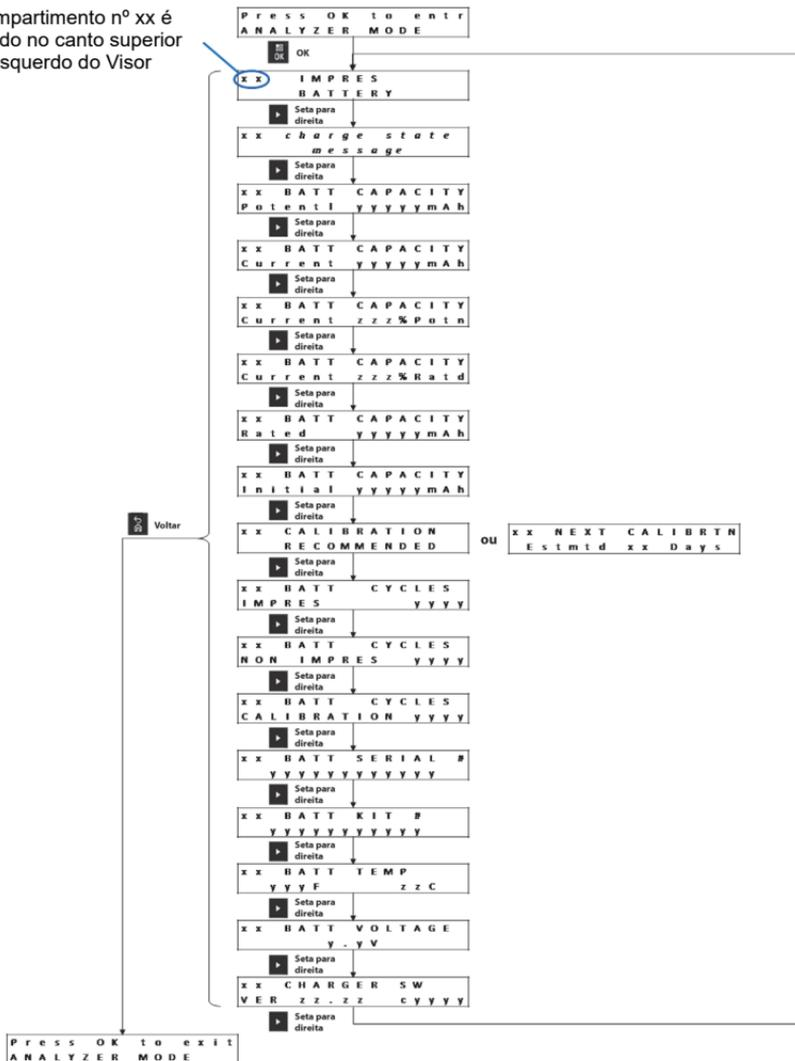
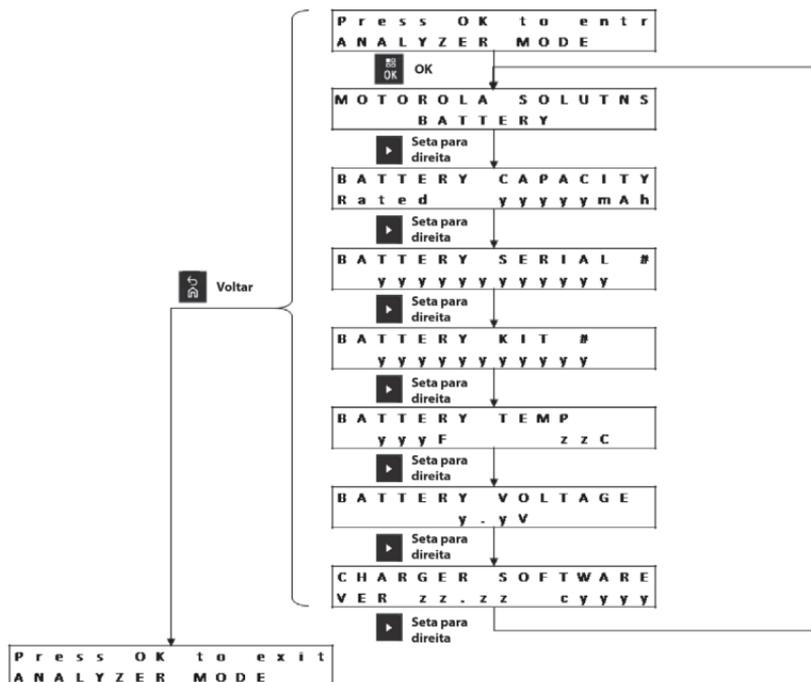

**Figura 22:** Outro Menu do Modo Analisador da Bateria da Motorola Solutions para Visor Adjacente ao Compartimento

## Compartimento nº 1 Exibindo outro Compartimento

Compartimento nº xx é exibido no canto superior esquerdo do Visor

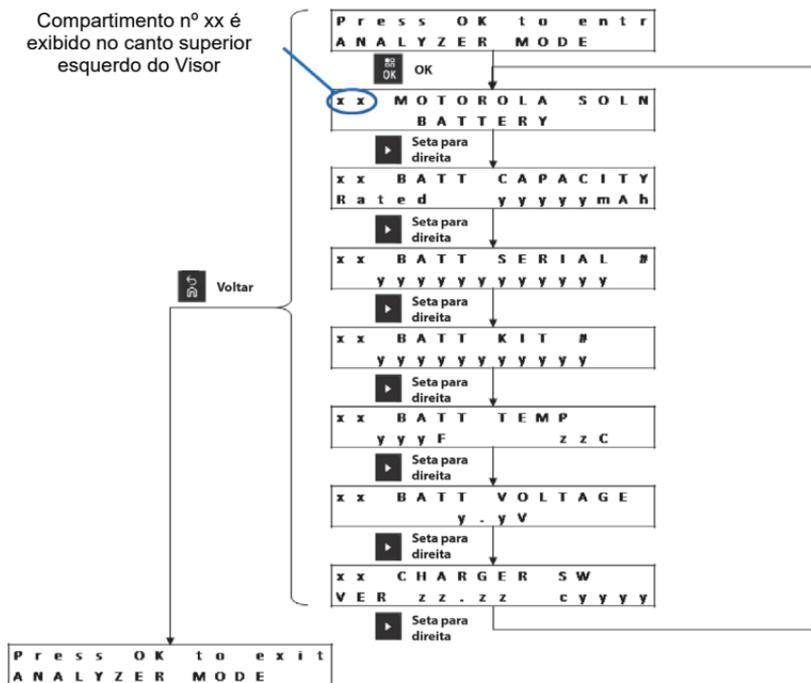

**Figura 23:** Outro Menu do Modo Analisador da Bateria da Motorola Solutions para Outro Compartimento (que não o Compartimento nº 1)

# Bateria Desconhecida

## Tela Adjacente ao Compartimento

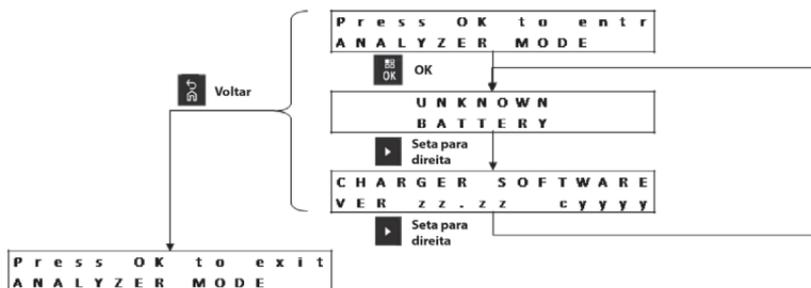

**Figura 24:** Menu do Modo Analisador da Bateria Desconhecido para Visor Adjacente ao Compartimento

## Compartimento nº 1 Exibindo outro Compartimento

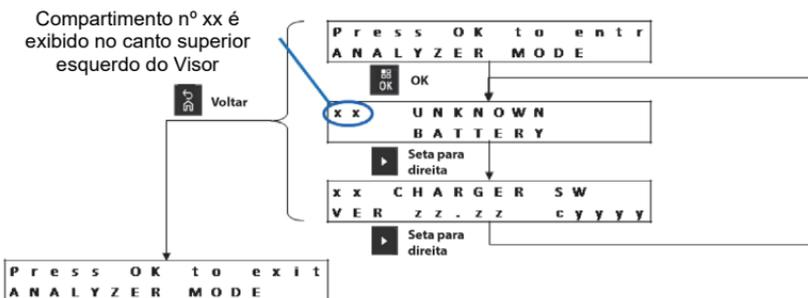

**Figura 25:** Menu do Modo Analisador da Bateria Desconhecido para Outro Compartimento (que não o Compartimento nº 1)

## Compartimento Vazio

### Tela Adjacente ao Compartimento



Figura 26: Menu do Modo Analisador para Compartimento Vazio Adjacente ao Visor

### Compartimento nº 1 Exibindo outro Compartimento

Compartimento nº xx é exibido no canto superior esquerdo do Visor

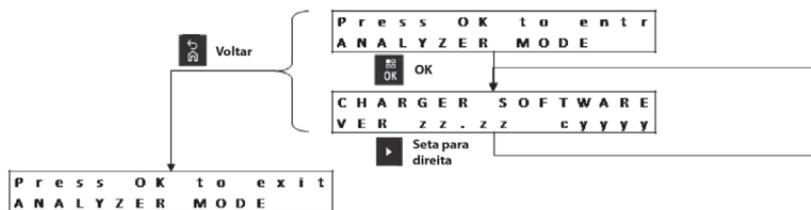

Figura 27: Menu do Modo Analisador para Compartimento Vazio (que não o Compartimento nº 1)

### Mensagem de Estado do Carregador

Algumas baterias IMPRES 2 são equipadas com um modo de Suspensão. No final da Remessa de Lítio, xx% Armazenamento de Longo Prazo ou 75% Armazenamento de Longo Prazo, uma bateria equipada com modo Suspensão é colocada em repouso. A Mensagem de Estado da Carga no Modo Analisador permite que você verifique o Estado da Carga de baterias em repouso.

**Tabela 21:** Remessa de Lítio Habilitada e Carga Completa de Lítio de Remessa da Bateria

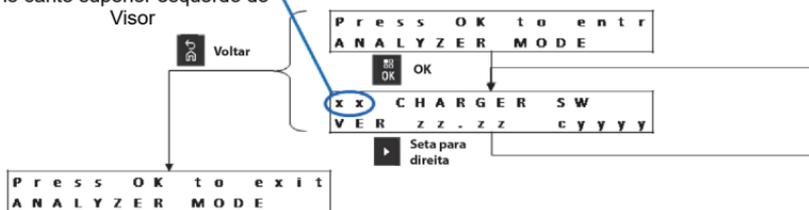
Tela Adjacente ao Compartimento	Compartimento nº 1 Exibindo outro Compartimento
SHIP LI SLEEP xxx% Rated Cap	xx SHIP LI SLEEP xxx% Rated Cap

**Tabela 22:** xx% de Armazenamento de Longo Prazo Habilitado e a Bateria Completou xx% de Carga de Armazenamento de Longo Prazo

Tela Adjacente ao Compartimento	Compartimento nº 1 Exibindo outro Compartimento
STORAGE SLEEP xxx% Rated Cap	xx STORAGE SLEEP xxx% Rated Cap

Por exemplo, a Mensagem de Estado do Carregador não é exibida se xx% Armazenamento de Longo Prazo estiver habilitado e a carga completa de 75% Armazenamento de Longo Prazo na bateria em um carregador diferente.

## Reprogramação do Carregador

A reprogramação do carregador requer que o Módulo de Comunicações seja conectado a um computador por meio de um cabo padrão USB. Ao usar o sistema de Gerenciamento de Frota de Baterias IMPRES para iniciar a reprogramação do carregador, as mensagens a seguir são exibidas pelo carregador.

Remova as baterias dos compartimentos do carregador antes da reprogramação:

```
REPROGRAMMING  
REMOVE BATTERIES
```

Todos os compartimentos do carregador estão vazios:

```
REPROGRAMMING  
WAITING FOR DATA
```

Os dados de reprogramação estão sendo baixados:

```
REPROGRAMMING  
Progress yyy%
```

Para carregadores com visor associado a cada compartimento, o valor percentual é a porcentagem de dados baixados com êxito para o compartimento associado ao monitor. Para carregadores que têm apenas um visor (Compartimento nº 1), o valor percentual é a porcentagem de dados baixados com êxito em todos os compartimentos.

Falha na reprogramação do compartimento identificado:

```
REPROGRAMMING  
POCKET#xx FAILED
```

O compartimento do carregador identificado começa as operações normais usando o software anterior.

O download dos dados de reprogramação foi concluído. O carregamento está concluindo o processo de Reprogramação.

```
IMPRES 2  
CHARGER
```

O processo de reprogramação foi concluído com sucesso.

```
REPROGRAMMING  
COMPLETE
```

O carregador começa as operações normais usando o software recém-baixado. A configuração definida pelo usuário é preservada após a conclusão da reprogramação do carregador.

# Solução de Problemas do Carregador

**Tabela 23:** Solução de problemas:  
Carregamento normal

Problema	O que fazer...
O LED do Compartimento não piscará em Verde por aproximadamente 1 segundo para ativação do carregador.	Certifique-se de que o cabo de alimentação esteja bem conectado no carregador e em uma tomada CA apropriada. Certifique-se de que haja alimentação na tomada. Verifique os fusíveis e substitua-os conforme necessário.
A bateria ou o rádio está inserido no compartimento, mas o LED do compartimento continua desligado e a bateria não é identificada no visor adjacente.	Se o compartimento não for o Compartimento nº 1 e a Economia de Energia estiver Habilitada, pressione um botão do Menu. Veja abaixo.
LED piscando em Vermelho e o Visor (se disponível) mostra: NOT CHARGEABLE REMOVE & REINSERT ou uma bateria Motorola Solutions está no compartimento, mas o Visor (se disponível) mostra: UNKNOWN BATTERY	 Remova a bateria ou o rádio do compartimento: Verifique os contatos elétricos na bateria e no compartimento do carregador em busca de contaminação, corrosão ou danos físicos. Verifique se a bateria é uma bateria autorizada da Motorola Solutions. Outras baterias podem não carregar. Limpe os contatos elétricos da bateria usando um pano seco. Corte a energia do carregador, depois limpe os contatos elétricos do compartimento usando um pano seco. Tente substituir a bateria. Se não houver mais falha, encerre as atividades da bateria defeituosa. Se a falha persistir com a bateria substituída, encerre as atividades do carregador.
Alternando entre LED vermelho / verde ao final da calibração.	  A bateria IMPRES 2 ou IMPRES pode estar quase no Fim da Vida Útil. A bateria é utilizável, mas a capacidade disponível pode não ser adequada para o uso intenso em um longo período. Aplicável somente para bateria APX NEXT XN: a bateria foi exposta a altas temperaturas por mais de 10 minutos. Recomenda-se retirar a bateria de serviço.

**Tabela 23:** Solução de problemas:  
Carregamento normal (Continuação)

Problema	O que fazer...
Alternando entre LED  âmbar / verde por aproximadamente 4 segundos na inserção da bateria no carregador.	A bateria IMPRES 2 ou IMPRES precisa de Calibração/ Recondicionamento. Na próxima oportunidade, coloque a bateria em um carregador IMPRES 2 que tenha Calibração habilitada e deixe que o carregador execute a Calibração (Verde Constante).
No Modo Analisador, o Compartimento nº 1 pode exibir outro compartimento.	O carregador não consegue detectar o visor em pelo menos um dos outros compartimentos.

**Tabela 24:** Solução de Problemas:  
Carga do Armazenamento de Longo Prazo

Problema	O que fazer...
LED piscando em Vermelho e o Visor (se disponível) mostra: WRONG BATT TYPE CANNOT LT STORE ou CANNOT DISCHARGE CANNOT LT STORE	<p>Remova a bateria do compartimento. Verifique se a bateria NÃO está conectada a um rádio.</p> <p>Verifique se a bateria é uma bateria IMPRES 2 ou IMPRES. Outras baterias falharão.</p> <p>Limpe os contatos elétricos da bateria IMPRES 2 ou IMPRES usando um pano seco.</p> <p>Corte a energia do carregador, depois limpe os contatos elétricos do compartimento usando um pano seco.</p> <p>Tente substituir a bateria por outra bateria IMPRES 2 ou IMPRES. Se não houver mais falha, então encerre as atividades da bateria IMPRES 2 ou IMPRES defeituosa.</p> <p>Se a falha persistir com a bateria IMPRES 2 ou IMPRES substituta, encerre as atividades do carregador.</p>
LED piscando em Vermelho e o Visor (se disponível) mostra: STORE INCOMPLETE Low Capacity:yy%	A Capacidade Potencial da bateria IMPRES 2 ou IMPRES pode ser menor do que a seleção do Armazenamento de Longo Prazo. A bateria pode estar quase no Fim da Vida Útil.



**Tabela 24:** Solução de Problemas:  
Carga do Armazenamento de Longo Prazo (Continuação)

Problema	O que fazer...
<p>LED piscando em Vermelho e o Visor (se disponível) mostra:</p> <p>WRONG BATT TYPE CANNOT SHIP LI</p> <p>ou</p> <p>CHARGING POCKET CANNOT LT STORE</p> 	<p>O compartimento do carregador não é o compartimento padrão para carregar uma bateria (por exemplo, através de contatos elétricos entre o carregador e a bateria).</p> <ul style="list-style-type: none"> <li>Um Compartimento de Rádio é um compartimento especial no qual a bateria é conectada a um rádio, não há contatos externos na bateria e a bateria é carregada através de contatos elétricos no rádio.</li> <li>Um Compartimento de Carregamento é um compartimento que usa energia do carregador para uma finalidade especial, como portas de carregamento USB.</li> </ul> <p>Mova a bateria para um compartimento padrão ou substitua o Compartimento de Rádio ou Compartimento de Carregamento com um compartimento padrão.</p>

**Tabela 25:** Solução de Problemas:  
Carga de Remessa de Lítio

Problema	O que fazer...
<p>LED piscando em Vermelho e o Visor (se disponível) mostra:</p> <p>WRONG BATT TYPE CANNOT SHIP LI</p> 	<p>Remova a bateria do compartimento. Verifique se a bateria NÃO está conectada a um rádio.</p> <p>Verifique se a bateria é uma IMPRES 2, IMPRES ou outra bateria de Íon de Lítio autorizada da Motorola Solutions. Outras baterias falharão.</p> <p>Limpe os contatos elétricos da bateria IMPRES 2, IMPRES ou outra bateria de Íon de Lítio autorizada da Motorola Solutions usando um pano seco.</p> <p>Corte a energia do carregador, depois limpe os contatos elétricos do compartimento usando um pano seco.</p> <p>Tente substituir a bateria por outra IMPRES 2, IMPRES ou outra bateria de Íon de Lítio autorizada da Motorola Solutions. Se não houver mais falha, então encerre as atividades da bateria defeituosa IMPRES 2, IMPRES ou outra bateria de Íon de Lítio autorizada da Motorola Solutions.</p> <p>Se a falha persistir com a bateria substituta IMPRES 2, IMPRES ou outra bateria de Íon de Lítio autorizada da Motorola Solutions, encerre as atividades do carregador.</p>

**Tabela 25:** Solução de Problemas:  
Carga de Remessa de Lítio (Continuação)

Problema	O que fazer...
<p>LED piscando em Vermelho e o Visor (se disponível) mostra:</p> <p>SHIP INCOMPLETE Low Capacity:yy%</p> 	<p>A Capacidade Potencial da bateria original de Íon de Lítio da Motorola Solutions pode ser menor que o Limite de Lítio da Remessa. A bateria pode estar quase no Fim da Vida Útil.</p>
<p>LED piscando em Vermelho e o Visor (se disponível) mostra:</p> <p>RADIO POCKET CANNOT LT STORE</p> <p>ou</p> <p>CHARGING POCKET CANNOT SHIP LI</p> 	<p>O compartimento do carregador não é o compartimento padrão para carregar uma bateria (por exemplo, através de contatos elétricos entre o carregador e a bateria).</p> <ul style="list-style-type: none"> <li>• Um Compartimento de Rádio é um compartimento especial no qual a bateria é conectada a um rádio, não há contatos externos na bateria e a bateria é carregada através de contatos elétricos no rádio.</li> <li>• Um Compartimento de Carregamento é um compartimento que usa energia do carregador para uma finalidade especial, como portas de carregamento USB.</li> </ul> <p>Mova a bateria para um compartimento padrão ou substitua o Compartimento de Rádio ou Compartimento de Carregamento com um compartimento padrão.</p>

## Sistema de Gerenciamento de Frota de Baterias IMPRES

O software de Gerenciamento de Frota de Bateria IMPRES coleta automaticamente os dados críticos de baterias IMPRES ou IMPRES 2 que são inseridas em um carregador IMPRES. Os dados essenciais incluem idade, capacidade, histórico de carga, histórico de Calibração/Recondicionamento, data de fabricação e a data de início de serviço. O software de Gerenciamento de Frota de Baterias IMPRES analisa os dados da bateria, comunica a integridade da bateria e recomenda quando substituí-la. Portanto, você pode determinar rápida e eficientemente quando uma bateria deve ou não ser usada novamente por um usuário menos exigente, quando adquirir uma nova bateria de reposição ou quando procurar uma bateria perdida.

O Gerenciamento de Frota de Baterias IMPRES oferece informações críticas sobre a bateria:

- Quando as baterias estão abaixo da capacidade aceitável.
- Ajuda a garantir que os usuários tenham capacidade suficiente para um turno inteiro de trabalho.
- Identifica baterias com baixa capacidade, para que possam ser retiradas de serviço.
- Elimina inatividade e interrupções de trabalho inesperadas.
- Evita o gasto de descartar baterias prematuramente.
- Confirma se os carregadores são distribuídos e utilizados de maneira ideal.

O software do aplicativo de Gerenciamento de Frota da Bateria IMPRES é expansível de um único site para um sistema em rede de vários sites, conforme representado em Figura 28. O Sistema de Gerenciamento de Frota da Bateria IMPRES é compatível com:

- Um Servidor Administrador do sistema
- 19 Clientes Remotos
- 25 Carregadores IMPRES ou Leitores de Bateria IMPRES por cliente
- 25.000 Baterias IMPRES no mesmo local ou em áreas geograficamente dispersas (o número total de baterias em todo o sistema não pode exceder 25.000)



**Figura 28:** Gerenciamento de Frota de Bateria IMPRES por Carregadores de Rede

O Gerenciamento de Frota de Baterias IMPRES consiste em três componentes principais:

- O software do aplicativo.
- Uma chave de licença de software.
- Um cabo USB para conectar o carregador IMPRES 2, o Módulo de Comunicações IMPRES 2, a Unidade de Interface do Carregador IMPRES (CIU) ou o Leitor de Dados da Bateria IMPRES para um computador que hospeda um Cliente Remoto.

Use os relatórios existentes para personalizar os novos a fim de ver as informações mais relevantes para a sua organização. Os dados são armazenados no seu banco de dados e podem ser exportados para um arquivo do Excel™ ou impressos. O software de Gerenciamento de Frota de Baterias IMPRES registra e organiza uma variedade de dados para que você possa:

- Consultar um instantâneo do status de toda a sua frota de bateria.
- Avaliar se as baterias estão atingindo seus critérios de desempenho.
- Determinar quando as baterias estão próximas de seu fim de sua vida útil.
- Decidir exatamente quando adquirir novas baterias.
- Obter um relatório de bateria perdida.
- Otimizar a utilização do seu carregador.
- Monitorar todos os dispositivos no sistema.

Serial Number	Alias	Group	Radio Family	Kit Number	Chemistry	IM	Trained Capacity	Potential Capacity	Date of Prod Use
100000024970	Sam	Building 1	WTS 2000/3000/2000	HWN00115	NiCd	Yes	1520	1590	8/12/2009
100000004540	João	Security	APR	WNTN7912A	NiMH	Yes	2100	1480	12/18/2008
100000018448	Michael	Security	APR	WNTN7916A	NiMH	Yes	2000	1400	2/14/2007
100000028231	Paul	Administration	WTS000/3000/2000	HWN00206	NiCd	Yes	1500	1290	2/4/2009
100000009112	Paul	Building 1	WTS 2000/3000/2000	WNTN4407B	NiMH	Yes	1300	1380	8/14/2008
100000024355	Steve	Building 1	WTS 2000/3000/2000	WNTN7915A	Li-Ion	Yes	2050	1440	1/24/2009
100000034801	John	Sales	WTS 2000/3000/2000	HWN00108	NiCd	Yes	1000	1000	8/26/2009
100000016415	Jack	Building 2	WTS 2000/3000/2000	WNTN7914A	Li-Ion	Yes	1050	1440	8/11/2008
100000083211	Steve	Building 2	WTS 2000/3000/2000	WNTN7915A	Li-Ion	Yes	2050	1440	8/21/2009
100000038420	John	None	Sales	HWN00108	NiCd	Yes	2000	1400	5/22/2009
100000030211	Carol	Administration	WTS000/3000/2000	HWN00206	NiCd	Yes	1480	1350	11/12/2008
100000041307	Pat	Building 1	WTS 2000/3000/2000	WNTN4401B	NiMH	Yes	1700	1207	3/21/2008
100000006100	Joe	Building 1	WTS 2000/3000/2000	HWN00118	NiCd	Yes	1420	1480	8/22/2008
100000033933	Bill	Security	APR	WNTN7913A	Li-Ion	Yes	1610	2911	7/21/2008
100000039021	Frank	Security	APR	WNTN7912A	NiMH	Yes	2100	1490	8/11/2008
100000004173	Mark	Building 2	WTS 2000/3000/2000	WNTN7915A	Li-Ion	Yes	1950	2000	11/18/2008
100000024233	Eric	Administration	WTS000/3000/2000	PRN00407A	Li-Ion	Yes	2130	1520	3/18/2008
100000026208	Henry	Administration	WTS000/3000/2000	HWN00108	NiCd	Yes	1400	1100	7/10/2008
100000006542	Paul	Building 1	APR	WNTN7912A	NiMH	Yes	2100	1490	5/22/2008
100000004902	Tom	Security	APR	WNTN7913A	Li-Ion	Yes	1610	2911	3/19/2009
100000009127	Bill	Administration	WTS000/3000/2000	HWN00206	NiCd	Yes	1550	1100	5/22/2009
100000004211	Joe	Building 2	WTS 2000/3000/2000	PRN00403A	NiMH	Yes	1000	1070	8/16/2007
100000024139	Paul	Administration	WTS000/3000/2000	PRN00403A	Li-Ion	Yes	1400	960	8/12/2009
100000016213	Frank	Building 1	APR	WNTN7912A	NiMH	Yes	2000	1380	7/20/2008
100000010912	Tom	Security	WTS000/3000/2000	PRN00403A	Li-Ion	Yes	1400	960	8/12/2007
100000010033	Arny	Administration	APR	WNTN7912A	NiMH	Yes	2100	1440	2/11/2008
100000017418	Geoff	Building 1	WTS000/3000/2000	HWN00108	NiCd	Yes	1400	1240	10/11/2007
100000013118	Gary	Security	WTS 2000/3000/2000	WNTN7914A	Li-Ion	Yes	1610	2860	8/15/2008
100000017623	Ben	Administration	APR	WNTN7912A	NiMH	Yes	2100	1440	8/17/2008
100000019791	Mark	Building 1	WTS000/3000/2000	PRN00403A	Li-Ion	Yes	1000	1030	10/11/2007

Figura 29: Relatório de Bateria Ativa



Figura 30: Baterias em Uso por Família de Rádios

Hardware (EMM) Fleet Management

File Edit Features Help

Export Refresh Previous Next Configuration Preferences Group About Help Exit

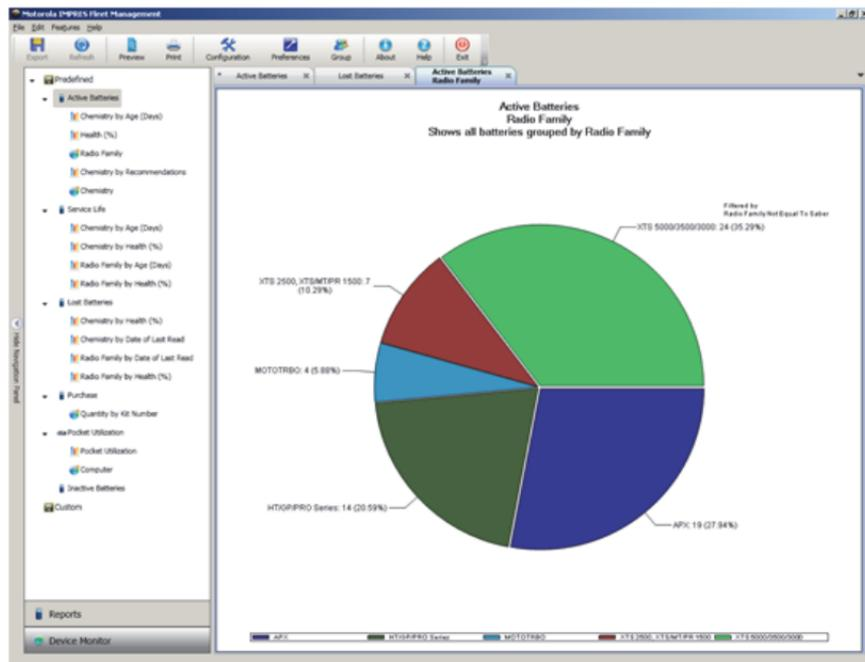
Active Batteries Active Batteries Radio Search Lost Batteries

Serial Number	Make	Group	Radio Family	Alt Number	Operational	Alt	Rated Capacity	Potential Capacity	Date of Next Use	Recommendations	Days since Last Used	Alt
00000101919	Sierra	Building 1	075 5000 10000 0000	000001019	Not OK	No	1420	1410	01/12/2018	Recharge / Calibrate Battery	140	10
00000101912	Sierra	Building 1	075 5000 10000 0000	007040410	Not OK	Yes	1750	1700	01/06/2018	No Recommendations	140	9
00000104008	Sierra	Building 1	075 5000 10000 0000	007040406	OK	Yes	2000	1900	01/24/2018	No Recommendations	140	8
00000104027	Sierra	Building 1	075 5000 10000 0000	007040428	Not OK	Yes	2750	2677	01/23/2018	No Recommendations	140	7
00000104020	Sierra	Building 1	075 5000 10000 0000	000001020	Not OK	No	1620	1602	01/22/2018	No Recommendations	140	7
00000101910	Sierra	Security	075 5000 10000 0000	007040416	Not OK	No	1710	1680	01/22/2018	No Recommendations	140	6
00000104228	Sierra	Administration	075 5000 10000 0000	000001028	OK	Yes	2000	1928	01/23/2018	No Recommendations	140	5
00000101911	Sierra	Building 1	075 5000 10000 0000	007040404	OK	Yes	2000	1900	01/23/2018	No Recommendations	140	5
00000101913	Sierra	Administration	075 5000 10000 0000	000001013	OK	No	2000	1700	01/23/2018	No Recommendations	140	4

No Recommendations

Reports

Device Monitor

Figura 31: Bateria Perdida por Localização

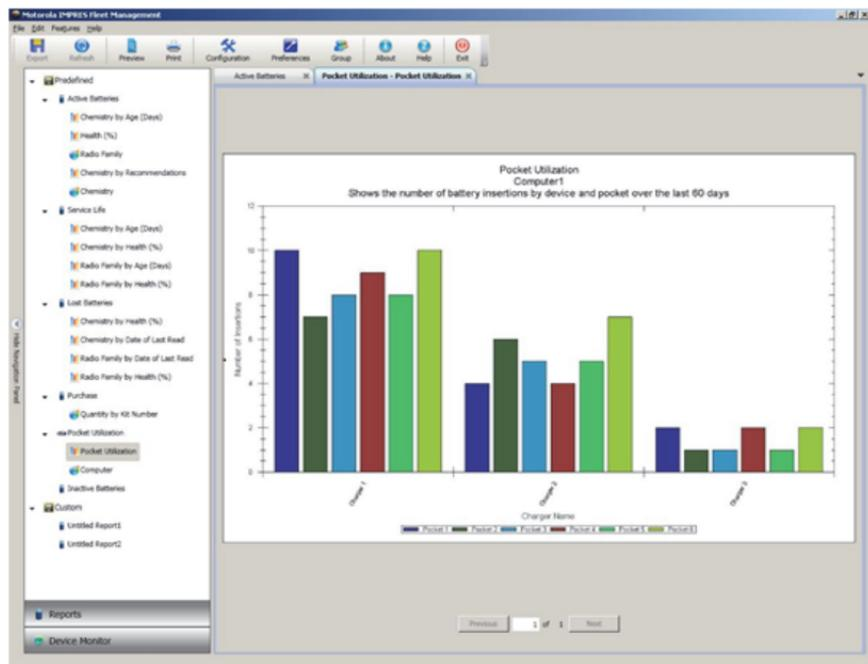

**Figura 32:** Utilização de Compartimento do Carregador



## Montagem em Parede do Carregador para Várias Unidades

Um suporte de montagem na parede (Número da Peça: 0705559L01) está disponível para o Carregador para Várias Unidades. Entre em contato com o revendedor local para solicitar este item. A instalação é exibida abaixo.



**AVISO**

- Este suporte de montagem em parede deve ser instalado por um técnico treinado e experiente. Ter o produto instalado por um técnico não especializado é muito perigoso e pode causar danos ou ferimentos.
- Não instale o produto quando o peso não for suportado. Se o local onde a montagem na parede está instalada não for forte o suficiente, ela poderá cair e causar lesões.
- Não instale em uma estrutura propensa a vibrações, movimentos ou chances de impacto.

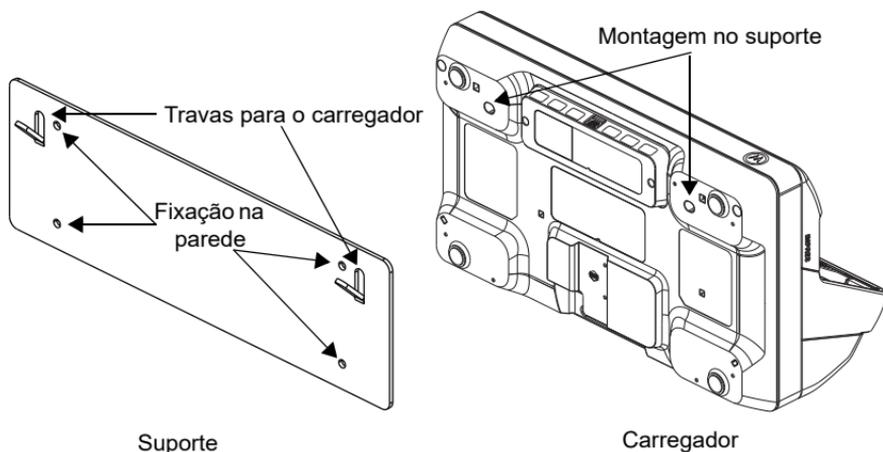

**Figura 33:** Orifícios de Montagem do Suporte e Posição das Travas

## Instalar o Carregador para Várias Unidades no Suporte de Parede

1. Posicione o suporte de montagem em parede na posição desejada e marque a localização dos furos de montagem na superfície da parede.



Atenção

Certifique-se de que a área atrás da superfície de montagem esteja sempre livre de fios elétricos, cabos e canos antes de cortar, perfurar ou instalar os parafusos de

2. Instale o suporte na parede utilizando o hardware de montagem apropriado, necessário para o tipo de fixação do material de parede no qual ele está sendo instalado. Perfure com base nos furos de montagem marcados na superfície da parede.
3. Fixe o suporte de parede na posição instalando firmemente o hardware de montagem sobre os furos de montagem no suporte de parede.

**Nota:** recomenda-se usar arruelas e parafusos autoatarrachantes de 10-16x1,5" (não incluído) em parede com viga de madeira e em parede de bloco/concreto sólido e plano.

4. Pendure o Carregador para Várias Unidades no suporte de parede.

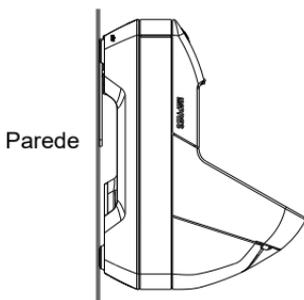

**Figura 34:** Carregador Montado no Suporte de Parede

## Notas

# 重要安全说明

## 请妥善保管这些说明

本文档包含重要的安全和操作说明。请仔细阅读这些说明，并妥善保管以供日后参考。

使用电池充电器之前，请阅读所有说明以及 (1) 充电器、(2) 电池和 (3) 使用电池的对讲机上的警示标记。



警告

1. 为了降低损坏电源线的风险，从交流插座或充电器中拔下电源线时，请捏住插头拔出，而不是拉电源线。
2. 除非绝对必要，否则请勿使用电源延长线。使用不合适的延长线可能会引发火灾或导致触电。如果必须使用延长线，请确保延长线的规格为 18 AWG（最长不得超过 6.5 英尺（2.0 米）的距离）或 16 AWG（最长不得超过 9.8 英尺（3.0 米）的距离）。
3. 为了降低火灾、触电或人员受伤的风险，请勿使用有任何破损或损坏的充电器。应将它交给 Motorola Solutions 专业服务代表处理。
4. 请勿拆开充电器。擅自拆开充电器可能导致触电或引发火灾。仅有的可维修/可更换部件是 NNTN9212 和 NNTN9213 充电座插件。遵循 APX 系列 IMPRES 2 多座充电器充电座插件套件 MN005697A01 中的说明。
5. 为了降低触电的风险，尝试对充电器进行维护或清洁之前，请先将充电器电源插头从交流插座上拔下。
6. 为了减少受伤风险，请仅对表 2 中列出的 Motorola Solutions 认可的充电电池进行充电。其他类型的电池可能会发生爆炸，导致人员受伤和财产损失。
7. 使用非 Motorola Solutions 推荐的附件可能会引发火灾、导致触电或人员受伤。

## 安全操作指南

- 本设备不适合在室外使用。请仅在干燥的场所和环境中使用。
- 充电器周围的最高环境温度不得超过 40°C (104°F)。
- 对讲机位于充电器充电座中时，请仅在对讲机以无线方式传输数据（例如使用 Wi-Fi 时）时打开对讲机。否则，请关闭对讲机。
- 只能将充电器连接到表 3 中列出的适当电源上。
- 电源线连接的交流插座必须位于附近，并且插拔方便。
- 确保连接到充电器的电源线置于适当的位置，以避免发生踩踏、绊倒、浸水、损伤或挤压等意外。
- 电源线只能与配有保险丝且电压匹配（产品上指定的电压）的有线交流电源插座连接。
- 通过从交流插座中拔下电源线来断开线路电压。
- 受所使用的经认证电源板的限制，将不超过适当数量的充电器连接至 15 A 或 20 A 电路。不推荐使用菊花链电源板。将电路负载限制在电路额定值的 80% 以下。
- 请仅使用 Motorola Solutions 认可的充电座。

## 支持的型号

表 1：支持的型号和说明

型号	说明
PS000029A01 (通用) PS000029A04 (欧洲/英国) PS000029A06 (韩国)	APX 单显示屏 IMPRES 2 多座充电器，带充电器重新编程和电池组管理
PS000029A02 (通用) PS000029A05 (欧洲/英国) PS000029A07 (韩国)	APX 6 显示屏 IMPRES 2 多座充电器，带充电器重新编程和电池组管理
PS000029A03 (欧洲/英国) PS000029A08 (韩国)	APX 6 显示屏 IMPRES 2 多座充电器，带充电器重新编程、电池组管理和 USB 附件充电
PS000337A01 (美国/北美地区/ 澳大利亚/ 新西兰)	APX NEXT 6 显示屏 IMPRES 2 多座充电器，带充电器重新编程和电池组管理

## Motorola Solutions 认可的电池

APX 系列 IMPRES 2 充电器可为表 2 中列出的电池充电。电池可安装在对讲机中，也可以是独立电池。

表 2：Motorola Solutions 认可的电池

套件 (PN)	说明
NNTN7033	IMPRES 锂离子 FM (HazLoc) IP67 4100 mAh
NNTN7034	IMPRES 锂离子 IP67 4200 mAh
NNTN7035	IMPRES 镍氢 FM (HazLoc) 坚固型 2000 mAh
NNTN7036	IMPRES 镍氢 FM (HazLoc) IP67 2000 mAh
NNTN7037	IMPRES 镍氢 IP67 2100 mAh
NNTN7038	IMPRES 锂离子 IP67 2900 mAh
NNTN7573	IMPRES 镍氢坚固型 2100 mAh
NNTN8092	IMPRES 锂离子 FM (HazLoc) 坚固型 2300 mAh
NNTN8182	IMPRES 锂离子坚固型 2900 mAh
NNTN8921	IMPRES 2 锂离子 TIA4950 (HazLoc) 坚固型 IP67 3700 mAh
NNTN8930	IMPRES 2 锂离子 TIA4950 (HazLoc) 坚固型 IP67 2700 mAh
NNTN9087	IMPRES 2 锂离子 IP68 3800 mAh
NNTN9088	IMPRES 2 锂离子 DIVISION 2 (HazLoc) IP68 3800 mAh

表 2：Motorola Solutions 认可的电池（续）

套件 (PN)	说明
NNTN9089	IMPRES 2 锂离子 IP68 5650 mAh
NNTN9090	IMPRES 2 锂离子 DIVISION 2 (HazLoc) IP68 5650 mAh
NNTN9126	IMPRES 2 锂离子 IP68 4400 mAh
NNTN9127	IMPRES 2 锂离子 DIVISION 2 (HazLoc) IP68 4400 mAh
PMNN4403	IMPRES 锂离子 IP67 2150 mAh
PMNN4485	IMPRES 2 锂离子坚固型 IP67 2500 mAh
PMNN4486	IMPRES 2 锂离子坚固型 IP67 3400 mAh
PMNN4487	IMPRES 2 锂离子坚固型 IP67 4400 mAh
PMNN4494	IMPRES 2 锂离子坚固型 IP67 5000 mAh
PMNN4504	IMPRES 2 锂离子 DIVISION 2 (HazLoc) 坚固型 IP67 3400 mAh
PMNN4505	IMPRES 2 锂离子 DIVISION 2 (HazLoc) 坚固型 IP67 4850 mAh
PMNN4547	IMPRES 2 锂离子 TIA4950 (HazLoc) 坚固型 IP68 3100 mAh
PMNN4573	IMPRES 2 锂离子 TIA4950 (HazLoc) 坚固型 IP68 4600 mAh
PMNN4812	APX NEXT XN IMPRES 2 锂离子 DIV 2 (HAZLOC) IP68 3400 mAh

## Motorola Solutions 认可的电源

表 3：Motorola Solutions 认可的电源

套件 (PN)	说明
3087791G01	电源线，美国 / 北美
3087791G04	电源线，欧洲
3087791G07	电源线，英国 / 中国香港
3087791G10	电源线，澳大利亚 / 新西兰
3087791G13	电源线，阿根廷
3087791G16	电源线，韩国
3087791G20	电源线，日本
3087791G22	电源线，巴西
CB000460A01	电源线，中国

## Motorola Solutions 认可的通信模块

表 4: Motorola Solutions 认可的通信模块

套件 (PN)	说明
AS000013A01	IMPRES 2 充电器重新编程和电池组管理模块
AS000012A02	IMPRES 2 充电器重新编程 / 电池组管理和附件充电模块

### 充电器、充电座和通信模块

APX 系列 IMPRES 2™ 自适应充电器系统是一种完全自动化的电池保养系统。充电器配备以下功能：

- 自适应充电支持大多数电池类型，其中包括 IMPRES 2、IMPRES™ 以及其他原装 Motorola Solutions 电池。
- 可容纳独立电池或安装了电池的对讲机的充电座。
- 红色/琥珀色/绿色 LED 指示充电器充电座状态。
- 通信模块
  - 充电器重新编程
  - IMPRES 2 或 IMPRES 电池数据上传到 IMPRES Battery Fleet Management 系统
  - (可选) 有 6 个 USB A 型充电端口，每个端口有 0.5A 电流用来为 USB 附件充电
- 键盘菜单
  - 充电器设置
  - 电池分析
- 充电座 #1 上的信息显示屏。
  - 其他充电座上的可选显示屏
- 让独立的 IMPRES 2 或 IMPRES 电池做好长期存放准备，或者让独立的 Motorola Solutions 锂离子电池做好运输准备。在做好长期存放准备或锂离子电池运输完成后，不要让电池留在充电器中。
- 节能功能
  - 符合加利福尼亚能源委员会有关小型电池充电系统的设备标准。充电器的充电座将自动休眠，然后可唤醒以响应用户操作或者保养充电座中的电池。
  - 遵守欧盟待机电流限制（欧盟充电器套件）。启用省电模式时，如果没有活动的时间长度达到指定的值，则除充电座 #1 外的所有充电器充电座都将自动关闭。按任意键盘按钮可重新打开这些充电座。



- IMPRES 2 锂离子电池充电速度更快。
- 更快速的充电。
- 延长电池使用寿命。

建议不要在对讲机正在充电器中充电时操作对讲机。

在充电过程中，操作对讲机可能会最大程度降低对讲机性能和延长电池充电时间。

在校准/修复过程中，电池会先完全放电后再充满电。因此，对讲机可能会在放电阶段关闭。建议在电池未安装在对讲机中或关闭安装在其中的对讲机的情况下校准电池。

## IMPRES 2 和 IMPRES 电池和充电器

### 功能和优点

IMPRES 2 能量解决方案是由 Motorola Solutions 开发的高级三重化学能量系统。此系统包括：

- IMPRES 2 和 IMPRES 电池
- IMPRES 2 自适应充电器
- IMPRES 对讲机

使用 IMPRES 2 自适应充电器为 IMPRES 2 或 IMPRES 电池充电，通过充电器定期校准或修复电池，具有以下优点：

- 延长电池使用寿命。
- 测量电池容量和确定电池当前的电量状态，为您指示有效使用时间。
- 监视 IMPRES 2 或 IMPRES 电池使用模式。
- 更新在 IMPRES 2 或 IMPRES 电池中存储的模式信息。
- 仅在需要时自动执行校准/修复。
- 无论电池在充电座中放多久，均可最大限度地减少 IMPRES 2 或 IMPRES 电池的发热。
- 定期“充满”存放在充电座中的电池，为用户保持较高的准备就绪状态。
- 消除镍电池的记忆效应，不再需要购买特殊任务装备或培训员工来维护电池使用寿命。

通过采用这种已获专利的独有系统，无需对 IMPRES 2 或 IMPRES 电池的使用进行追踪和记录，无需进行手动校准/修复过程，也无需在充电完成后从充电器中取下电池。

## IMPRES 2 或 IMPRES 电池初始化

要获得完整的 IMPRES 2 或 IMPRES 功能，必须通过充电器初始化新的 IMPRES 2 或 IMPRES 电池。充电器会自动检测新的 IMPRES 2 或 IMPRES 电池，并自动开始初始化。初始化是 IMPRES 2 或 IMPRES 电池的第一次 IMPRES 电池校准/修复。此过程分两个阶段。第一个阶段为电池放电，通过呈琥珀色长亮的 LED 指示灯指示。第二个阶段为充满电，最终通过呈绿色长亮的 LED 指示灯指示。此过程可能需要 12 个小时或更长时间来完成，时间长短取决于电量状态和电池的容量。中断任何一个阶段都会将初始化推迟到下一次充电机会。

## IMPRES 2 或 IMPRES 充电座到充电座

为 IMPRES 2 或 IMPRES 电池充电时，IMPRES 2 或 IMPRES 充电器将在电池内存中记录充电信息。如果将 IMPRES 2 或 IMPRES 电池从一个 IMPRES 2 或 IMPRES 充电器充电座中取下，且在 30 分钟内将其插入另一个或同一个 IMPRES 2 或 IMPRES 充电器充电座中，则将在充电中断处继续充电。此功能可防止电池过度充电，从而可以最大限度延长使用寿命。此功能在为镍电池充电时尤为重要。

## 自动 IMPRES 2 或 IMPRES 电池校准/修复

IMPRES 2 充电器会自动评估 IMPRES 2 或 IMPRES 电池的状况。根据评估的状况，充电器会自动校准/修复电池。中断放电阶段或充满电阶段，都会将校准推迟到下一次充电机会。

使用充电器设置模式启用或禁用校准/修复。在禁用后，当 IMPRES 2 或 IMPRES 电池需要校准/修复时，在插入电池时以及电池充完后，LED 指示灯将显示交替的琥珀色/绿色。

**注意：**IMPRES 2 或 IMPRES 电池必须放置在充电器充电座外面 30 分钟以上，才能进行自动校准/修复。

## 带自校准和修复功能的 IMPRES 电池



**注意：**当接入此 IMPRES 2 充电器（软件版本 V2.05 或更高版本）时，电池标签上有此图标的 IMPRES 2 电池不需要进行定期校准和修复。

**注释：** 确保不断通过最新的固件更新充电器。MSI Charger Reprogrammer 应用程序包可从 Motorola Online (MOL) 或 Motorola Solutions 网站下载。

## 更新固件

**注释：** 适用于所有 IMPRES 第 1 代和第 2 代设备或充电器，包括充电器接口单元(CIU)、电池数据读取器(BDR)、单座充电器(SUC)、双座充电器 (DUC) 和多座充电器 (MUC)。

在将 IMPRES 设备或充电器升级到最新版本之前，请先从目标设备或充电器中取出所有插入的电池。

1. 使用 USB 将设备或充电器连接至计算机。连接的设备或充电器显示在 MSI Charger Reprogrammer 的主窗口中。

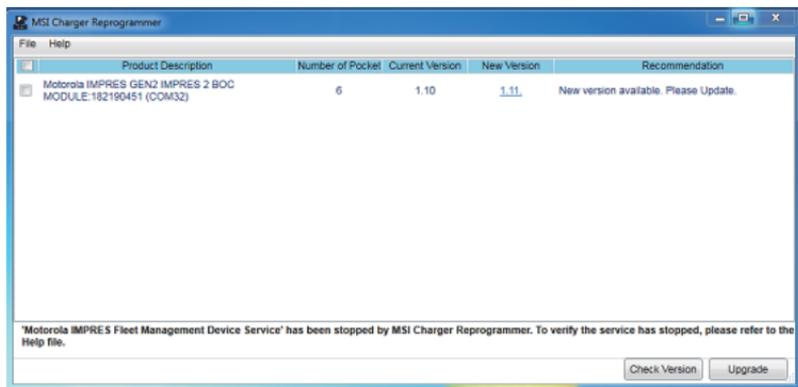

2. 单击 Check Version，从 MSI 服务器查找最新可用版本。

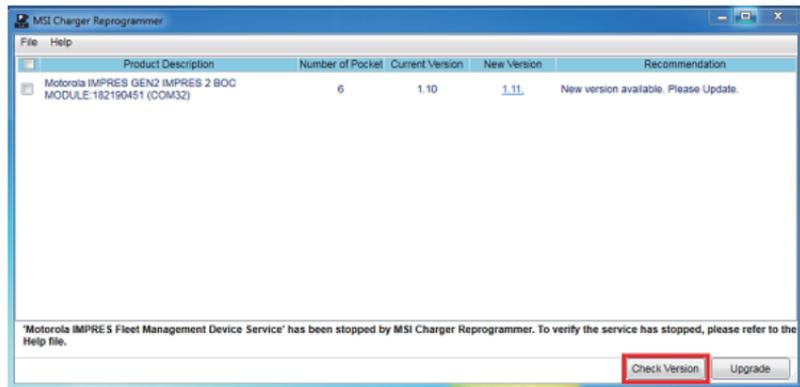

### 3. 选择需要更新的设备或充电器。

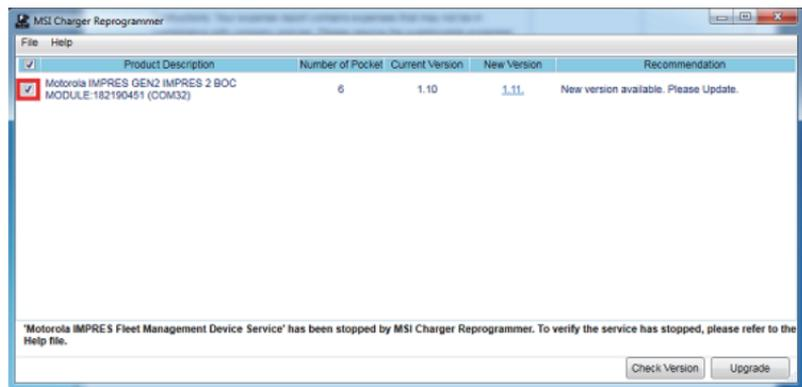

**注释：** 您不能选择已更新了最新固件版本的设备或充电器。

### 4. 要启动固件升级，请单击 Upgrade。

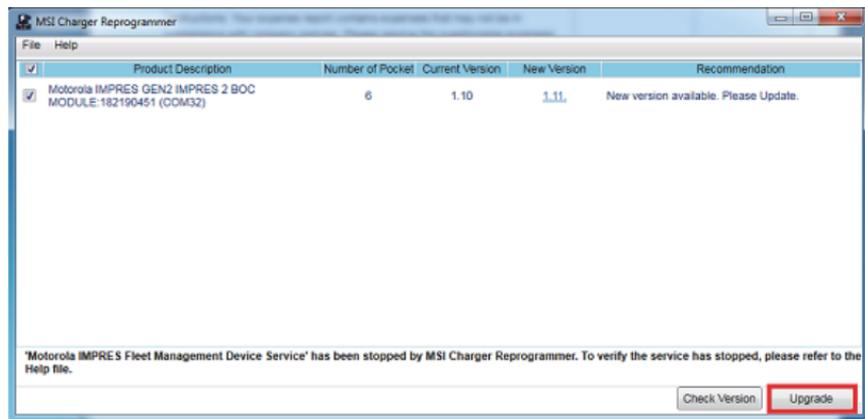

5. 当系统提示开始升级时，单击确认窗口上的 OK。一个窗口显示升级的进度，直到完成。

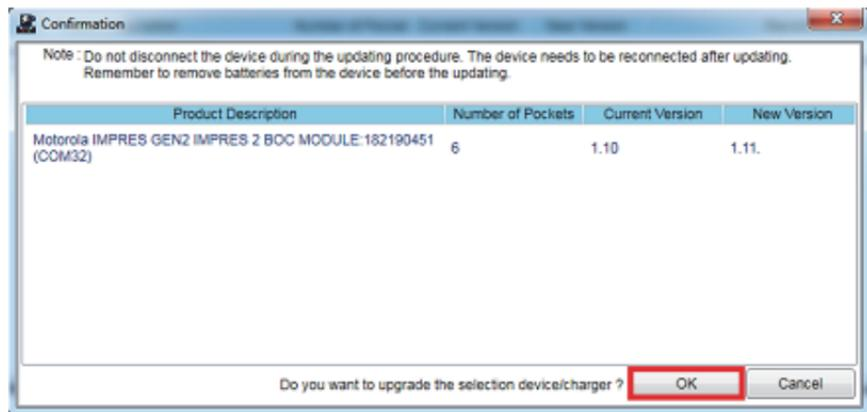

6. 完成所有升级后，关闭窗口。

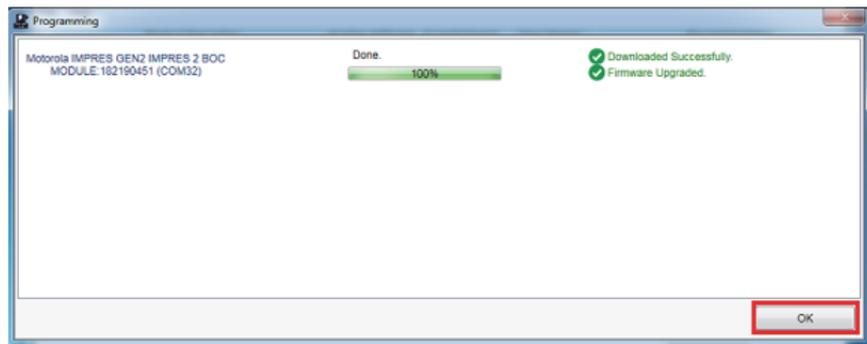

## 手动启动校准/修复



**注意：**手动校准或修复不适用于具有此图标的 IMPRES 或 IMPRES 2 电池。

尽管校准/修复是自动进行的，但是在某些情况下，可能需要手动启动。例如，充电器可能会针对 IMPRES 2 或 IMPRES 电池显示**交替的琥珀色/绿色**，因为在充电器中禁用了校准。如果在 30 分钟内将电池放入已启用校准的充电器中，则会从上次的充电状态继续充电，并会阻止校准/修复自动开始。

要手动启动校准/修复，请将 IMPRES 2 或 IMPRES 电池从充电器中取下超过 2.5 分钟。然后，执行以下步骤：

1. 将电池插入充电器的充电座中。
2. 在 2.5 分钟内，从充电器的充电座中取出电池。
3. 在 5 秒内，将电池重新插入到充电器的充电座中。

校准/修复将立即开始，通常先进行电池放电（**呈琥珀色长亮**）。只有当电池充满电（**呈绿色长亮**）后，校准/修复才算完成。

### 手动终止校准/修复

在 IMPRES 2 或 IMPRES 电池放电（呈琥珀色长亮）期间的任何时间，都可执行以下步骤来终止校准/修复：

1. 从充电器的充电座中取出电池。
2. 在 5 秒内，将电池重新插入到充电器的充电座中。

电池放电立即终止，开始正常的电池充电。LED 指示灯指示充电状态。

### 充电器概述



图 1：充电器概述

表 5：充电器概述和说明

编号	名称	说明
1-6	充电器充电座	每个充电座可以容纳一部兼容的对讲机或独立电池
7	通信模块	在某些充电器中，通信模块还可为 USB 附件充电： • 欧洲/英国 PS000029A03 • 韩国 PS000029A08
8	充电座 LED 状态指示灯	充电状态 LED 指示灯（每个充电座一个）
9	显示屏	充电座 #1 之外的充电座的可选显示屏
10	键盘显示屏	含菜单键盘的充电座 #1 显示屏
11	交流入口插座	使用特定国家或地区的专用电源线

## IMPRES 2 或 IMPRES 使用寿命到期 LED 指示灯指示

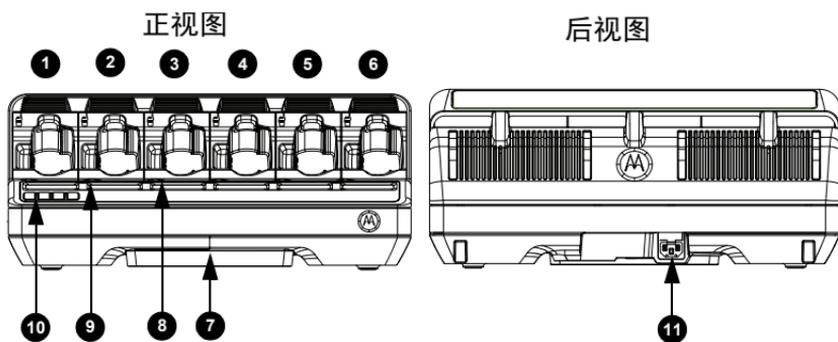
在校准/修复成功完成时，充电器可能会指示 IMPRES 2 或 IMPRES 电池使用寿命到期（显示交替的红色/绿色）。

在使用电池时，正常磨损也会减少可用容量。成功完成校准/修复后，充电器会将 IMPRES 2 或 IMPRES 电池容量与电池的额定容量进行比较。当容量值非常低时，IMPRES 2 或 IMPRES 电池的使用寿命可能即将结束。IMPRES 2 或 IMPRES 电池可继续使用。在某些情况下，可能需要将这类电池部署给不需要大电池容量就能够完成工作轮班的工作人员。

APXNEXTXN 电池附带高温检测功能，可通过 IMPRES2 充电器（软件版本 V2.05 或更高版本）进行检测。启用此功能后，对于长期暴露于极端高温环境下的电池，充电完成后，状态 LED 指示灯会呈红色和绿色交替闪烁。充电器显示内容如下：

```
REPLACE BATTERY
EXPOSED OVERTEMP
```

建议移除这样的电池，停止使用。

## 为独立电池或安装了电池的对讲机充电

电池最好在室温下进行充电。IMPRES 2 多座充电器可为独立电池充电，也可为安装在对讲机中的电池充电。

1. 将充电器放置在平坦的表面上。
2. 将电源线牢固地插入充电器背面的充电器交流入口插座中。
3. 将电源线插入匹配电源插座中。
4. 成功开机后，每个充电状态 LED 指示灯都将呈绿色闪烁约一秒钟，并显示 IMPRES 2 CHARGER。如果充电器状态 LED 指示灯不闪烁并且不显示任何消息，请检查电源线连接。
5. 将安装了电池的对讲机或独立电池插入可用的充电座中。

**注意：**将对讲机插入充电器，或者从充电器取出对讲机时，请握住对讲机机身。避免拉对讲机天线。

6. 对讲机或独立电池正确放入充电座后，关联充电状态 LED 指示灯将指示充电状态。相关的显示屏将提供其他信息。对于单显示屏充电器，其显示屏仅提供充电座 #1 的充电状态。
7. 充电状态为呈绿色长亮时，电池已准备就绪，可以使用。
8. 仅当将充电器通信模块与 PC 分离后，才打开对讲机。否则，请关闭设备或对讲机。



图 2：为安装在对讲机中的电池充电



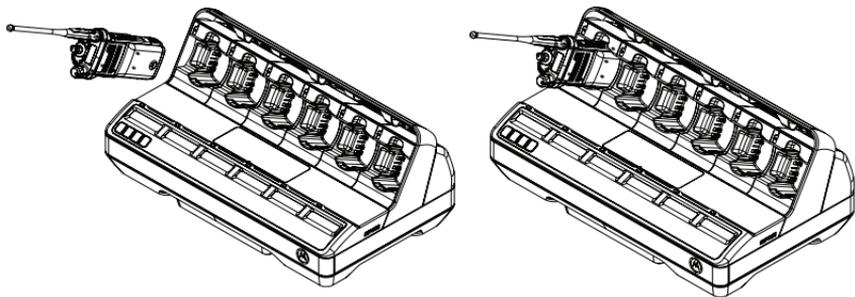

图 3：为独立电池充电

## 为 USB 附件充电

某些 IMPRES 2 多座充电器通信模块提供 USB Type-A 插座为 USB 附件充电。USB 附件在室温充电效果最好。

1. 将 IMPRES 2 自适应充电器放置在平坦表面。
2. 将电源线牢固地插入充电器背面的充电器交流插座中。
3. 将电源线插入匹配电源插座中。
4. 成功开机后，每个充电座状态 LED 指示灯都将呈绿色闪烁约 1 秒钟，并显示 IMPRES 2 CHARGER。如果状态 LED 指示灯不闪烁并且不显示任何消息，请检查电源线连接。
5. USB 附件可能有一个 Micro-AB 充电插孔。使用 1 米或更短的标准 USB 电缆，电缆一端为 Type A 插头，另一端为与附件兼容的插头（通常为 Micro-B 或 Micro-AB）。
6. 调整 USB 电缆 Type A 插头的方向，使其与通信模块上的 Type A 端口正确对齐。将插头插入端口。
7. 调整 USB 电缆 Micro-B 插头的方向，使其与 USB 附件上的 Micro-AB 插孔正确对齐。将插头插入到插孔中。
8. 当 USB 连接已正确就位后，USB 附件将指示充电状态。有关详细信息，请参阅 USB 附件的《用户指南》。

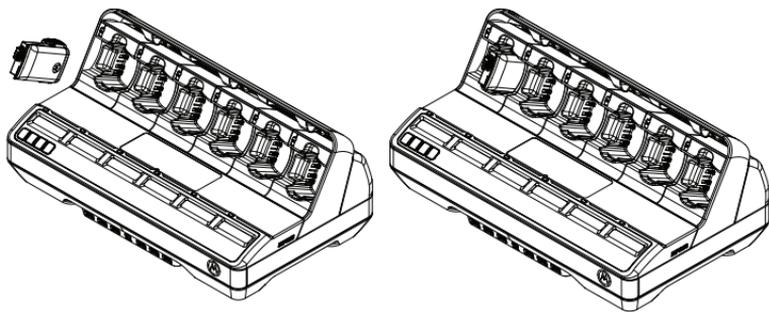
## 充电指示

表 6：IMPRES 2 或 IMPRES 电池的充电指示 – 不需要校准

状态	充电座显示屏	LED 指示灯
充电器开启	IMPRES 2 CHARGER	呈绿色亮起约 1 秒钟 
检测到电池	IMPRES 2 BATTERY 或 IMPRES BATTERY	呈红色长亮 
正在快速充电	RAPID CHARGE XXXX@mAh yy%Pt1	呈红色长亮 
充电至 90% 或更多	TRICKLE CHARGE xxxx@mAh yy%Pt1	绿色闪烁 
充电至 95% 或更多	CHARGE COMPLETE xxxx@mAh yy%Pt1	呈绿色长亮 
故障	警告: NOT CHARGEABLE REMOVE & REINSERT	红色闪烁 
待机 • 电池正在等待快速充电。 • 电池过热、过冷或低电压。 • 充电器过热。	警告: HOT BATTERY WAITING TO CHARGE 或 COLD BATTERY WAITING TO CHARGE 或 VERY LOW BATTERY WAITING TO CHARGE 或 HOT CHARGER WAITING TO CHARGE	琥珀色闪烁 

## 注意：

- Hot Charger 消息在 V1.05 软件中引入。
- 表示潜在容量与额定容量之比的充电器百分比状态指示在 V1.11.01 软件中引入。

表 7：IMPRES 2 或 IMPRES 电池校准的充电指示 – 启用校准

状态	充电座显示屏	LED 指示灯
充电器开启	IMPRES 2 CHARGER	呈绿色亮起约 1 秒钟 
检测到电池	IMPRES 2 BATTERY 或 IMPRES BATTERY	呈琥珀色长亮 
电池放电	CAL DISCHARGE xxxx@mAh yy%Pt1	呈琥珀色长亮 
正在快速充电	CAL RAPID CHARGE xxxx@mAh yy%Pt1	呈红色长亮 
充电至 90% 或更多	CAL TRICKLE CHARGE xxxx@mAh yy%Pt1	绿色闪烁 
充电至 95% 或更多	CHARGE COMPLETE xxxx@mAh yy%Pt1	电池校准成功： 呈绿色长亮   电池校准成功，电池可能接近服务寿命上限（电池仍可用）： 红色/绿色闪烁 
	REPLACE BATTERY EXPOSED OVERTEMP	电池校准成功，但电池暴露于累积的高温环境下（建议从电池组中移除）： 呈红色/绿色闪烁  注释：仅适用于 APX NEXT XN 电池
故障	警告： NOT CHARGEABLE REMOVE & REINSERT	红色闪烁 
待机 <ul style="list-style-type: none"> <li>• 电池正在等待快速充电。</li> <li>• 电池过热、过冷或低电压。</li> <li>• 充电器过热。</li> </ul>	警告： HOT BATTERY WAITING TO CAL 或 COLD BATTERY WAITING TO CAL 或 VERY LOW BATTERY WAITING TO CHARGE 或 HOT CHARGER WAITING TO CAL	琥珀色闪烁 

表 8：IMPRES 2 或 IMPRES 电池校准的充电指示 – 校准初始禁用，然后启用

状态	充电器显示屏	LED 指示灯
充电器开启	IMPRES 2 CHARGER	呈绿色亮起约 1 秒钟 
检测到电池	IMPRES 2 BATTERY 或 IMPRES BATTERY	电池需要校准，但充电器中禁用了校准： 交替显示琥珀色/绿色 4 秒钟  
请求 IMPRES 电池校准 • 校准在充电器中已禁用。 • 电池正在充电	警告： ENABLE BATTERY CALIBRATION? • 按 OK 以启用校准 • 正常充电时忽略 (消息在 1 分钟后删除)	呈红色长亮 
电池放电 • 选定 OK	CAL DISCHARGE xxxxx@mAh yyy%P t1	呈琥珀色长亮 
正在快速充电	CAL RAPID CHARGE xxxxx@mAh yyy%P t1	呈红色长亮 
充电至 90% 或更多	CAL TRICKLE CHARGE xxxxx@mAh yyy%P t1	绿色闪烁 
充电至 95% 或更多	CHARGE COMPLETE xxxxx@mAh yyy%P t1	电池校准成功： 呈绿色长亮 
	REPLACE BATTERY EXPOSED OVERTEMP	电池校准成功，但电池暴露于累积的高温环境下（建议从电池组中移除）： 呈红色/绿色闪烁  
故障	警告： NOT CHARGEABLE REMOVE& REINSERT	红色闪烁 

**表 8：IMPRES 2 或 IMPRES 电池校准的充电指示 – 校准初始禁用，然后启用（续）**

<p>待机</p> <ul style="list-style-type: none"> <li>• 电池正在等待快速充电。</li> <li>• 电池过热、过冷或低电压。</li> <li>• 充电器过热。</li> </ul>	<p>警告：</p> <p>HOT BATTERY WAITING TO CAL</p> <p>或</p> <p>COLD BATTERY WAITING TO CAL</p> <p>或</p> <p>VERY LOW BATTERY WAITING TO CHARGE</p> <p>或</p> <p>HOT CHARGER WAITING TO CAL</p>	<p>琥珀色闪烁</p> 
---	--	--

表 9：IMPRES 2 或 IMPRES 电池的充电指示 – 需要校准，但未启用

状态	充电器显示屏	LED 指示灯
充电器开启	IMPRES 2 CHARGER	呈绿色亮起约 1 秒钟 
检测到电池	IMPRES 2 BATTERY 或 IMPRES BATTERY	电池需要校准，但充电器中禁用了校准： 交替显示琥珀色/绿色 4 秒钟  
请求 IMPRES 电池校准 • 校准在充电器中已禁用。 • 电池正在充电。	警告： ENABLE BATTERY CALIBRATION? • 按 OK 以启用校准。 • 正常充电时忽略 (消息在 1 分钟后 删除)。	呈红色长亮 
正在快速充电 • 校准请求超时。	RAPID CHARGE xxxxx0mAh yyy%P t1	呈红色长亮 
充电至 90% 或更多	TRICKLE CHARGE xxxxx0mAh yyy%P t1	绿色闪烁 
充电至 95% 或更多	CHARGE COMPLETE xxxxx0mAh yyy%P t1	交替显示琥珀色/绿色  
故障	警告： NOT CHARGEABLE REMOVE& REINSERT	红色闪烁 
待机 • 电池正在等待快速充电。 • 电池过热、过冷或 低电压。 • 充电器过热。	警告： HOT BATTERY WAITING TO CHARGE 或 COLD BATTERY WAITING TO CHARGE 或 VERY LOW BATTERY WAITING TO CHARGE 或 HOT CHARGER WAITING TO CHARGE	琥珀色闪烁 

**表 10: 充满电的 IMPRES 2 或 IMPRES 电池的充电指示 – 需要校准, 但未启用**

状态	充电器显示屏	LED 指示灯
充电器开启	IMPRES 2 CHARGER	呈绿色亮起约 1 秒钟 
检测到电池	IMPRES 2 BATTERY 或 IMPRES BATTERY	电池需要校准, 但在过去 30 分钟内充满电, 并且已在充电器中禁用校准。 交替显示琥珀色/绿色 
故障	警告: NOT CHARGEABLE REMOVE & REINSERT	红色闪烁 
待机 • 电池正在等待快速充电。 • 电池过热、过冷或低电压。 • 充电器过热。	警告: HOT BATTERY WAITING TO CHARGE 或 COLD BATTERY WAITING TO CHARGE 或 VERY LOW BATTERY WAITING TO CHARGE 或 HOT CHARGER WAITING TO CHARGE	琥珀色闪烁 

## 其他 Motorola Solutions 电池

表 11：其他 Motorola Solutions 电池的充电指示

状态	充电器显示屏	LED 指示灯
充电器开启	IMPRES 2 CHARGER	呈绿色亮起约 1 秒钟 
检测到电池	MOTOROLA SOLUTIONS BATTERY	呈红色长亮 
正在快速充电	RAPID CHARGE	呈红色长亮 
充电至 90% 或更多	TRICKLE CHARGE	绿色闪烁 
充电至 95% 或更多	CHARGE COMPLETE	呈绿色长亮 
故障	警告： NOT CHARGEABLE REMOVE & REINSERT	红色闪烁 
待机 • 电池正在等待快速充电。 • 电池过热、过冷或低电压。 • 充电器过热。	警告： HOT BATTERY WAITING TO CHARGE 或 COLD BATTERY WAITING TO CHARGE 或 VERY LOW BATTERY WAITING TO CHARGE 或 HOT CHARGER WAITING TO CHARGE	琥珀色闪烁 



## 未知电池

充电器可能检测不到某些未知电池。未知电池不会以充电器可识别的方式声明充电参数。如果检测到未知电池，充电器将会以表 12 中总结的方式指示充电。

**表 12：未知电池的充电指示**

状态	充电器显示屏	LED 指示灯
充电器开启	IMPRES 2 CHARGER	呈绿色亮起约 1 秒钟 
检测到电池	UNKNOWN BATTERY	呈红色长亮 
正在快速充电	RAPID CHARGE	呈红色长亮 
几乎充满 • 电池容量未知	TRICKLE CHARGE	绿色闪烁 
已充满 • 电池容量未知	CHARGE COMPLETE	呈绿色长亮 
故障	警告： NOT CHARGEABLE REMOVE & REINSERT	红色闪烁 
待机 • 电池正在等待快速充电。 • 电池过热、过冷或低电压。 • 充电器过热。	警告： HOT BATTERY WAITING TO CHARGE 或 COLD BATTERY WAITING TO CHARGE 或 VERY LOW BATTERY WAITING TO CHARGE 或 HOT CHARGER WAITING TO CHARGE	琥珀色闪烁 

## IMPRES 2 或 IMPRES 电池长期存放

通过使用 IMPRES 2 多座充电器，可让独立的原装 Motorola Solutions IMPRES 2 或 IMPRES 电池（锂离子电池或镍电池）做好长期存放在合适的存放位置的准备。其他电池类型会出现故障。如果 IMPRES 2 电池配有睡眠模式，则在完成长期存放充电时，充电器会将电池置于睡眠状态。

只能让 IMPRES 2 或 IMPRES 电池做好长期存放准备。先将电池从对讲机中取出，再将其放入充电器中。

请勿将独立电池存放在充电器中。长期存放准备完毕后，立即从充电器中取下独立电池。

Long-Term Storage 选择优先于 Calibration/Reconditioning。准备好长期存放的锂离子电池可能不符合空运法规。

**表 13：IMPRES 2 或 IMPRES 电池的长期存放指示 – 电池校准时间到**

状态	充电器显示屏	LED 指示灯
充电器开启	IMPRES 2 CHARGER	呈绿色亮起约 1 秒钟 
检测到电池	IMPRES 2 BATTERY 或 IMPRES BATTERY	电池需要校准： 交替显示琥珀色/绿色 4 秒钟 
电池放电	STORAGE DISCHARGE xxxx% Rated Cap	呈琥珀色长亮 
正在快速充电	STORAGE CHARGE xxx% Rated Cap	呈红色长亮 
Long-Term Storage 完成	LONGTERM STORAGE xxx% Rated Cap	交替显示琥珀色/绿色 

表 13: IMPRES 2 或 IMPRES 电池的长期存放指示 – 电池校准时间到 (续)

状态	充电器显示屏	LED 指示灯
<p>故障</p> <ul style="list-style-type: none"> <li>• 电池与充电器电气接触不良。</li> <li>• 电池不是 IMPRES 2 或 IMPRES 电池。</li> <li>• 未知条件阻止电池放电。</li> <li>• 充电已完成但未达到长期存放目标。</li> <li>• 充电座属于特殊类型。</li> </ul>	<p>警告:</p> <p>NOT CHARGEABLE REMOVE&amp; REINSERT</p> <p>或</p> <p>WRONG BATT TYPE CANNOT LT STORE</p> <p>或</p> <p>CANNOT DISCHARGE FOR LT STORAGE</p> <p>或</p> <p>STORE INCOMPLETE Low Capacity:yy%</p> <p>或</p> <p>RADIO POCKET CANNOT LT STORE</p> <p>或</p> <p>CHARGING POCKET CANNOT LT STORE</p>	<p>红色闪烁</p> 
<p>待机</p> <ul style="list-style-type: none"> <li>• 电池正在等待快速充电。</li> <li>• 电池过热、过冷或低电压。</li> <li>• 充电器过热。</li> </ul>	<p>警告:</p> <p>HOT BATTERY WAITING TO CHRGE</p> <p>或</p> <p>COLD BATTERY WAITING TO CHRGE</p> <p>或</p> <p>VERY LOW BATTERY WAITING TO CHRGE</p> <p>或</p> <p>HOT CHARGER WAITING TO CHRGE</p>	<p>琥珀色闪烁</p> 

**注意:**

- 以下消息在版本 V1.05 软件中引入:
  - Cannot Discharge, for LT Storage
  - Store Incomplete, Low Capacity:yy%
  - Hot Charger, Waiting to Chrge
- 以下消息在版本 V1.11.01 软件中引入:
  - Wrong Batt Type, Cannot LT Store
  - Radio Pocket, Cannot LT Store
  - Charging Pocket, Cannot LT Store

**表 14: IMPRES 2 或 IMPRES 电池的长期存放指示 – 已校准电池, 必须充电到选择的值**

状态	充电器显示屏	LED 指示灯
充电器开启	IMPRES 2 CHARGER	呈绿色亮起约 1 秒钟 
检测到电池	IMPRES 2 BATTERY 或 IMPRES BATTERY	呈红色长亮 
正在快速充电	STORAGE CHARGE xxx% Rated Cap	呈红色长亮 
Long-Term Storage 完成	LONGTERM STORAGE xxx% Rated Cap	呈绿色长亮 
故障 <ul style="list-style-type: none"> <li>• 电池与充电器电气接触不良。</li> <li>• 电池不是 IMPRES 2 或 IMPRES 电池。</li> <li>• 未知条件阻止电池放电。</li> <li>• 充电已完成但未达到长期存放目标。</li> <li>• 充电座属于特殊类型。</li> </ul>	警告: NOT CHARGEABLE REMOVE& REINSERT 或 WRONG BATT TYPE CANNOT LT STORE 或 CANNOT DISCHARGE FOR LT STORAGE 或 STORE INCOMPLETE Low Capacity:yy% 或 RADIO POCKET CANNOT LT STORE 或 CHARGING POCKET CANNOT LT STORE	红色闪烁 
待机 <ul style="list-style-type: none"> <li>• 电池正在等待快速充电。</li> <li>• 电池过热、过冷或低电压。</li> <li>• 充电器过热。</li> </ul>	警告: HOT BATTERY WAITING TO CHRGE 或 COLD BATTERY WAITING TO CHRGE 或 VERY LOW BATTERY WAITING TO CHRGE 或 HOT CHARGER WAITING TO CHRGE	琥珀色闪烁 

**表 15: IMPRES 2 或 IMPRES 电池的长期存放指示 – 已校准电池，必须放电到选择的值**

状态	充电器显示屏	LED 指示灯
充电器开启	IMPRES 2 CHARGER	呈绿色亮起约 1 秒钟 
检测到电池	IMPRES 2 BATTERY 或 IMPRES BATTERY	呈琥珀色长亮 
电池放电	STORAGE DISCHARGE xxx% Rated Cap	呈琥珀色长亮 
Long-Term Storage 完成	LONGTERM STORAGE xxx% Rated Cap	呈绿色长亮 
故障 <ul style="list-style-type: none"> <li>• 电池与充电器电气接触不良。</li> <li>• 电池不是 IMPRES 2 或 IMPRES 电池。</li> <li>• 未知条件阻止电池放电。</li> <li>• 充电已完成但未达到长期存放目标。</li> <li>• 充电座属于特殊类型。</li> </ul>	警告: NOT CHARGEABLE REMOVE& REINSERT 或 WRONG BATT TYPE CANNOT LT STORE 或 CANNOT DISCHARGE FOR LT STORAGE 或 STORE INCOMPLETE Low Capacity:yy% 或 RADIO POCKET CANNOT LT STORE 或 CHARGING POCKET CANNOT LT STORE	红色闪烁 
待机 <ul style="list-style-type: none"> <li>• 电池正在等待快速充电。</li> <li>• 电池过热、过冷或低电压。</li> <li>• 充电器过热。</li> </ul>	警告: HOT BATTERY WAITING TO CHRGE 或 COLD BATTERY WAITING TO CHRGE 或 VERY LOW BATTERY WAITING TO CHRGE 或 HOT CHARGER WAITING TO CHRGE	琥珀色闪烁 

## 让锂离子电池做好运输准备

使用 IMPRES 2 多座充电器，可让独立的 IMPRES 2、IMPRES 或其他原装 Motorola Solutions 锂离子电池做好空运准备。其他电池类型会出现故障。如果 IMPRES 2 锂离子电池配有睡眠模式，则在完成 Ship Lithium 充电时，充电器会将电池置于睡眠状态。

只能让独立的 Motorola Solutions 锂离子电池做好运输准备。先将电池从对讲机中取出，再将其放入充电器中。

请勿将独立电池存放在充电器中。Lithium Shipment 准备完毕后，立即从充电器中取下独立电池。

Lithium Shipment 选择优先于 Calibration/Reconditioning。

### IMPRES 2 或 IMPRES 电池

**表 16:** 让锂离子电池做好运输准备的状态指示 – IMPRES 2 或 IMPRES 电池校准时间到

状态	充电器显示屏	LED 指示灯
充电器开启	IMPRES 2 CHARGER	呈绿色亮起约 1 秒钟 
检测到电池	IMPRES 2 BATTERY 或 IMPRES BATTERY	电池需要校准： 交替显示琥珀色/绿色 4 秒钟 
电池放电	SHIP LI DISCHRG xxx% Rated Cap	呈琥珀色长亮 
正在快速充电	SHIP LI CHARGE xxx% Rated Cap	呈红色长亮 
Ship Lithium 完成	LI READY TO SHIP xxx% Rated Cap	交替显示琥珀色/绿色 

**表 16：让锂离子电池做好运输准备的状态指示 – IMPRES 2 或 IMPRES 电池校准时间到（续）**

状态	充电器显示屏	LED 指示灯
<p>故障</p> <ul style="list-style-type: none"> <li>• 电池与充电器电气接触不良。</li> <li>• 电池是未知电池或是镍电池。</li> <li>• 未知条件阻止电池放电。</li> <li>• 充电已完成但未达到锂离子电池运输目标。</li> <li>• 充电座属于特殊类型。</li> </ul>	<p>警告：</p> <p>NOT CHARGEABLE REMOVE&amp; REINSERT 或 WRONG BATT TYPE CANNOT SHIP LI 或 CANNOT DISCHARGE FOR LI SHIPMENT 或 SHIP INCOMPLETE Low Capacity:yy% 或 RADIO POCKET CANNOT SHIP LI 或 CHARGING POCKET CANNOT SHIP LI</p>	<p>红色闪烁</p> 
<p>待机</p> <ul style="list-style-type: none"> <li>• 电池正在等待快速充电。</li> <li>• 电池过热、过冷或低电压。</li> <li>• 充电器过热。</li> </ul>	<p>警告：</p> <p>HOT BATTERY WAITING TO CHRG 或 COLD BATTERY WAITING TO CHRG 或 VERY LOW BATTERY WAITING TO CHRG 或 HOT CHARGER WAITING TO CHRG</p>	<p>琥珀色闪烁</p> 

**注意：**

- 以下消息在版本 V1.05 软件中引入：
  - Ship LI Discharge, xxx% Rated Capacity
  - Ship LI Charge, xxx% Rated Capacity
  - LI Ready to Ship, xx% Rated Capacity
  - Cannot Discharge, for LI Shipment
  - Ship Incomplete, Low Capacity:yy%
- 以下消息在版本 V1.11.01 软件中引入：
  - Wrong Batt Type, Cannot Ship LI
  - Radio Pocket, Cannot Ship LI
  - Charging Pocket, Cannot Ship LI

表 17：让锂离子电池做好运输准备的状态指示 – IMPRES 2 或 IMPRES 电池已校准，必须充电

状态	充电器显示屏	LED 指示灯
充电器开启	IMPRES 2 CHARGER	呈绿色亮起约 1 秒钟 
检测到电池	IMPRES 2 BATTERY 或 IMPRES BATTERY	呈红色长亮 
正在快速充电	SHIP LI CHARGE xxx% Rated Cap	呈红色长亮 
Ship Lithium 完成	LI READY TO SHIP xxx% Rated Cap	呈绿色长亮 
故障 <ul style="list-style-type: none"> <li>• 电池与充电器电气接触不良。</li> <li>• 电池未知或是镍电池</li> <li>• 未知条件阻止电池放电。</li> <li>• 充电已完成但未达到锂离子电池运输目标。</li> <li>• 充电座属于特殊类型。</li> </ul>	警告： NOT CHARGEABLE REMOVE& REINSERT 或 WRONG BATT TYPE CANNOT SHIP LI 或 CANNOT DISCHARGE FOR LI SHIPMENT 或 SHIP INCOMPLETE Low Capacity:yy% 或 RADIO POCKET CANNOT SHIP LI 或 CHARGING POCKET CANNOT SHIP LI	红色闪烁 
待机 <ul style="list-style-type: none"> <li>• 电池正在等待快速充电。</li> <li>• 电池过热、过冷或低电压。</li> <li>• 充电器过热。</li> </ul>	警告： HOT BATTERY WAITING TO CHRGE 或 COLD BATTERY WAITING TO CHRGE 或 VERY LOW BATTERY WAITING TO CHRGE 或 HOT CHARGER WAITING TO CHRGE	琥珀色闪烁 



**表 18：让锂离子电池做好运输准备的状态指示 – IMPRES 2 或 IMPRES 电池已校准，必须放电**

状态	充电器显示屏	LED 指示灯
充电器开启	IMPRES 2 CHARGER	呈绿色亮起约 1 秒钟 
检测到电池	IMPRES 2 BATTERY 或 IMPRES BATTERY	呈琥珀色长亮 
电池放电	SHIP LI DISCHARGE xxx% Rated Cap	呈琥珀色长亮 
Ship Lithium 完成	LI READY TO SHIP xxx% Rated Cap	呈绿色长亮 
故障 <ul style="list-style-type: none"> <li>• 电池与充电器电气接触不良。</li> <li>• 电池未知或是镍电池</li> <li>• 未知条件阻止电池放电。</li> <li>• 充电已完成但未达到锂离子电池运输目标。</li> <li>• 充电座属于特殊类型。</li> </ul>	警告： NOT CHARGEABLE REMOVE& REINSERT 或 WRONG BATT TYPE CANNOT SHIP LI 或 CANNOT DISCHARGE FOR LI SHIPMENT 或 SHIP INCOMPLETE Low Capacity:yy% 或 RADIO POCKET CANNOT SHIP LI 或 CHARGING POCKET CANNOT SHIP LI	红色闪烁 
待机 <ul style="list-style-type: none"> <li>• 电池正在等待快速充电。</li> <li>• 电池过热、过冷或低电压。</li> <li>• 充电器过热。</li> </ul>	警告： HOT BATTERY WAITING TO CHRGE 或 COLD BATTERY WAITING TO CHRGE 或 VERY LOW BATTERY WAITING TO CHRGE 或 HOT CHARGER WAITING TO CHRGE	琥珀色闪烁 

## 其他 Motorola Solutions 电池

表 19：让锂离子做好运输准备的状态指示 – 其他 Motorola Solutions 电池

状态	充电器显示屏	LED 指示灯
充电器开启	IMPRES 2 CHARGER	呈绿色亮起约 1 秒钟 
检测到电池	MOTOROLA SOLUTIONS BATTERY	呈琥珀色长亮 
电池放电	SHIP LI DISCHARGE xxx% Rated Cap	呈琥珀色长亮 
正在快速充电	SHIP LI CHARGE xxx% Rated Cap	呈红色长亮 
Ship Lithium 完成	LI READY TO SHIP xxx% Rated Cap	呈绿色长亮 
故障 <ul style="list-style-type: none"> <li>• 电池与充电器电气接触不良。</li> <li>• 电池未知或是镍电池</li> <li>• 未知条件阻止电池放电。</li> <li>• 充电已完成但未达到锂离子电池运输目标。</li> <li>• 充电座属于特殊类型。</li> </ul>	警告： NOT CHARGEABLE REMOVE& REINSERT 或 WRONG BATT TYPE CANNOT SHIP LI 或 CANNOT DISCHARGE FOR LI SHIPMENT 或 SHIP INCOMPLETE Low Capacity:yy% 或 RADIO POCKET CANNOT SHIP LI 或 CHARGING POCKET CANNOT SHIP LI	红色闪烁 
待机 <ul style="list-style-type: none"> <li>• 电池正在等待快速充电。</li> <li>• 电池过热、过冷或低电压。</li> <li>• 充电器过热。</li> </ul>	警告： HOT BATTERY WAITING TO CHARGE 或 COLD BATTERY WAITING TO CHARGE 或 VERY LOW BATTERY WAITING TO CHARGE 或 HOT CHARGER WAITING TO CHARGE	琥珀色闪烁 

## 充电器设置菜单



进行充电器设置之前，先清空所有充电器的充电座。

充电器键盘位于充电座 #1 显示屏的下方。

要进入 Charger Setup，请同时按住向左箭头和向右箭头超过 Entry Time 选项中的值（默认为 3 秒）

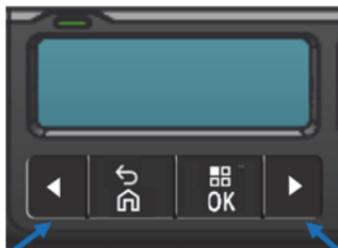

向左箭头

向右箭头

图 4：用于进入 Setup Mode 的菜单显示按钮

### 主菜单

进入 Charger Setup 后，将显示以下消息：

Press OK to entr  
SETUP MENU

按 OK 提示显示可用的 Charger Setup Menu。



图 5: Charger Setup 菜单

## 充电器设置菜单选项

在每个 Setup 菜单选项内：

- 要依顺序浏览菜单选项，请按向右箭头。
- 要依相反顺序浏览菜单选项，请按向左箭头。
- 要进入选定菜单或选择所需选项，请按 OK。

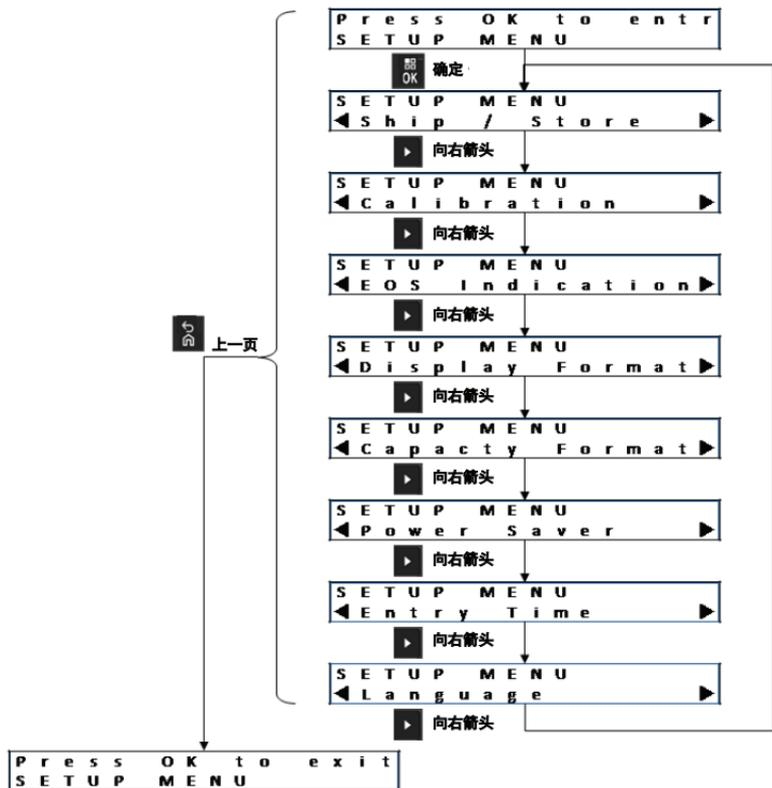
**注意：**复选标记标识当前选定的选项。

在 V1.11.01 中引入，按 OK 以在充电座 #1 显示屏上显示下一个充电座。

- 要退出选定菜单，请按“上一页”，然后按 OK 确认退出。



## 运输锂离子电池选项 (Ship Lithium)

Ship Lithium 会将 Motorola Solutions 锂离子电池的电量状态设置为散装运输允许的低电量值：约为额定容量的 25%。

某些 Motorola Solutions 电池可能会先完全放电，然后再充电到 Ship Lithium 限制。此类电池包括之前从未校准过或者需要新校准的 IMPRES 2 或 IMPRES 电池，以及不属于 IMPRES 2 或 IMPRES 电池的其他原装 Motorola Solutions 电池。

Ship Lithium 仅适用于原装 Motorola Solutions 锂离子电池（IMPRES 2、IMPRES 或其他 Motorola Solutions 锂离子电池）。其他类型的电池（例如未知电池或 Motorola Solutions 镍电池或蛤壳式电池）都会出现故障。

## 长期存放选项 (Long-Term Storage)

Long-Term Storage 会将 IMPRES 2 或 IMPRES 电池设置为合适的电量状态，以便长时间存放该电池。通常，首选存放电量状态明显少于满电量。xx% 选项是在 IMPRES 2 或 IMPRES 电池中预设的值，或者默认为额定容量的 50%。Long-Term Storage at 75% Rated Capacity 适用于需要以较高电量状态存放电池的情形，例如在需要快速调用电池时，能够最大限度地减少电池充满电所需的时间，或者允许存放更长时间。

某些 IMPRES 2 或 IMPRES 电池可能会先完全放电，再充电到 Long-Term Storage 选项。此类电池是从未校准或需要新校准的 IMPRES 2 或 IMPRES 电池。

Long-Term Storage 仅适用于 IMPRES 2 或 IMPRES 电池。其他类型的电池（例如未知电池或 Motorola Solutions 非 IMPRES 电池或蛤壳式电池）都会出现故障。

## 配有睡眠模式的 IMPRES 2 电池

某些 IMPRES 2 电池配有睡眠模式。使用睡眠模式可延长需要再次为电池充电的时间。在 Ship Lithium 或 Long-Term Storage 充电完成后，充电器会将这些电池置于睡眠状态。

将任何处于睡眠状态的 IMPRES 2 电池放到充电器中可将其唤醒。如果电池已做好 Lithium Shipment 准备，则将其放置到设置为 Lithium Shipment 的充电器中会将其放置回睡眠状态。如果电池已做好 Long-Term Storage 准备，则将其放置到设置为 Long-Term Storage 的充电器中会将其放置回睡眠状态。

## 校准菜单

Calibration 设置选项可启用或禁用校准/修复的放电阶段。对于成功的电池校准/修复，会先完成“放电”阶段，然后再充满电。当部署充电器的位置要求电池尽快可供使用时，此功能非常有用。在这些情况下，等待电池放电可能会带来不便。

如果 IMPRES 2 或 IMPRES 电池校准时间到并且在插入到充电器时已放电，则充电器需要使用充电完成作为电池校准的机会。



图 7：校准菜单





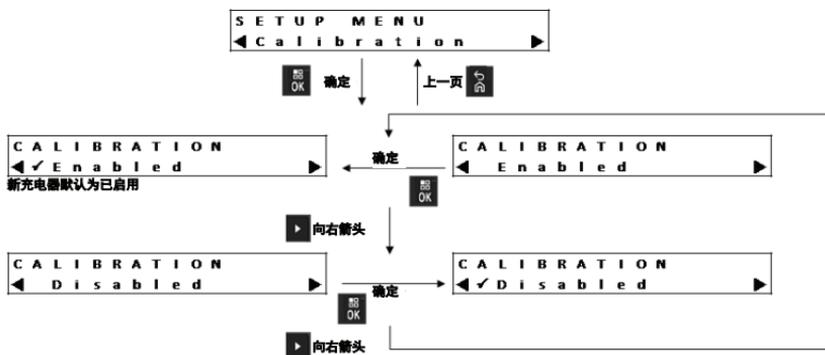

## 容量格式菜单

电池电量以几种可用格式之一显示。如果电池电量显示为百分比，则该百分比通常指代潜在容量（满电量）或额定容量之一。IMPRES 对讲机通常显示指代潜在容量的电池容量百分比。



图 10：容量格式菜单



## 进入时间菜单

Entry Time 是进入 Charger Setup 模式或 Charger Analyzer 模式所需的按住按钮的时间。

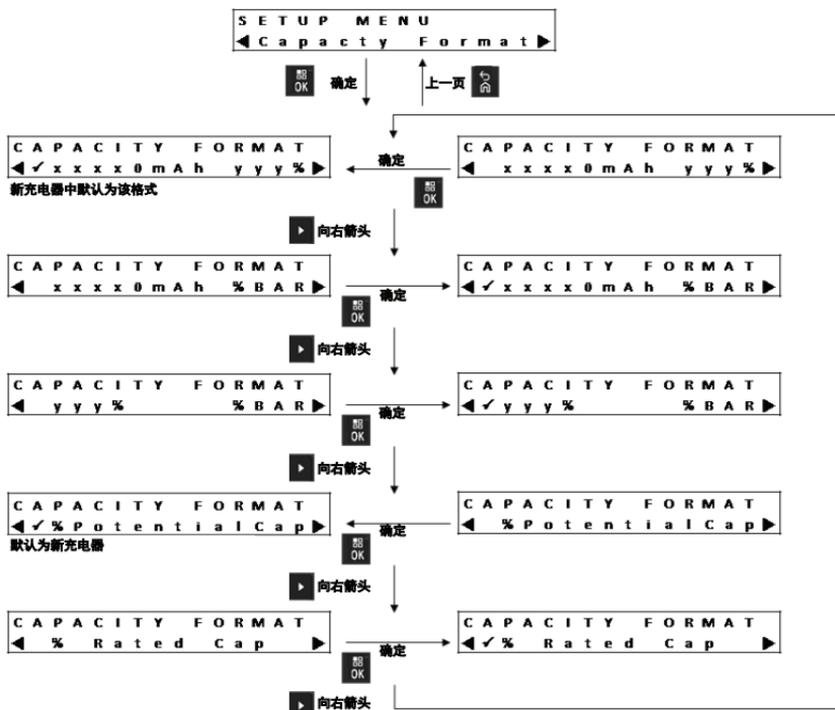

图 12: 进入时间菜单

## 语言菜单

当前，充电器显示有关语言的支持：北美英语。

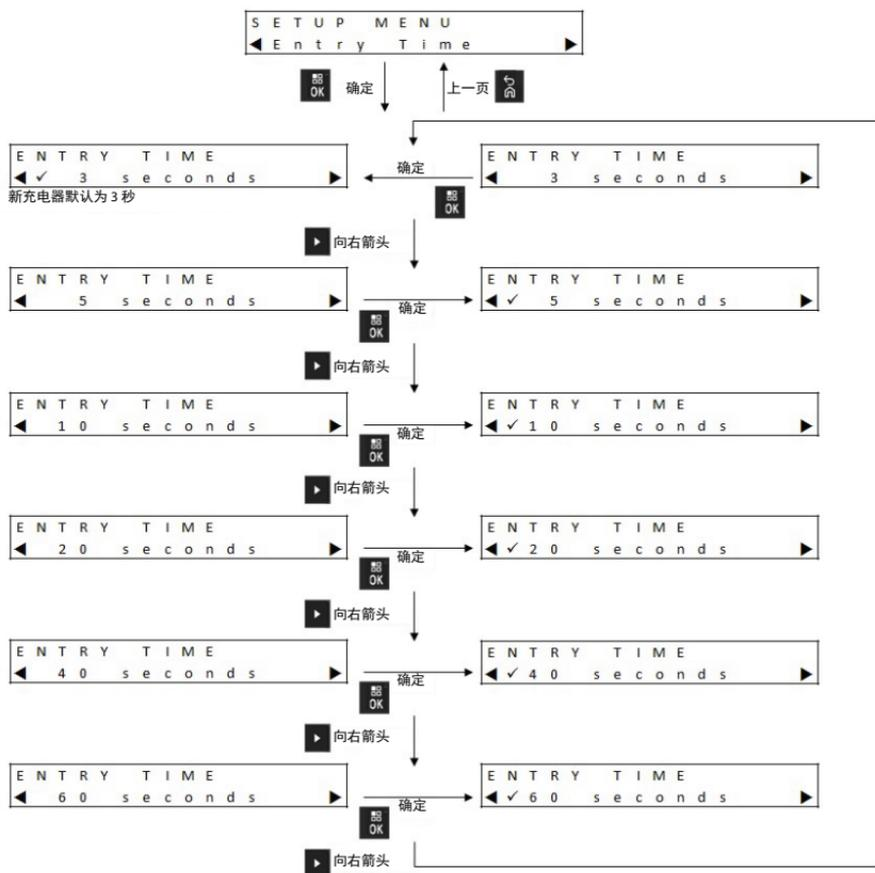

图 13：语言菜单

## 分析器模式

充电器键盘位于充电座 #1 显示屏的下方。

要进入 Analyzer Mode，请按住 OK 按钮超过 Entry Time 选项中的值（默认为 3 秒）。

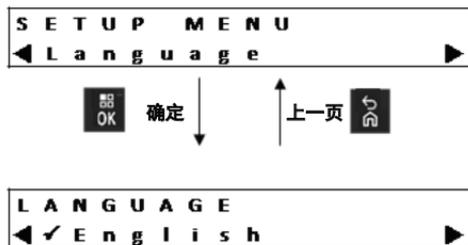
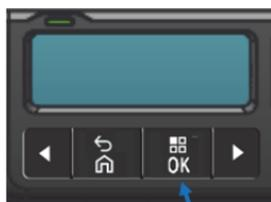

确定

图 14：用于进入 Analyzer Mode 的菜单显示按钮

进入 Analyzer Mode 后，将显示以下消息：

```
Press OK to entr
ANALYZER MODE
```

按 OK 会提示显示可用的电池信息。

## 版本 V1.0 分析器模式

在软件版本 V1.0 中，Analyzer Mode 限制为充电座 #1。有关充电座 #1 及其内容的 Analyzer 信息显示在充电座 #1 显示屏上。如果 10 分钟内没有按任何键盘按钮，充电器将退出 Analyzer Mode，并且返回到正常消息显示。



图 15：版本 V1.0 分析器模式菜单

## 版本 V1.05 分析器模式

发行软件版本 V1.05 后，Analyzer Mode 得到增强。对于每个充电座都有显示屏的充电器，Analyzer 信息会显示在其邻近充电座的显示屏上。在充电座 #1 上浏览 Analyzer 信息时，其他显示屏会浏览其邻近充电座的可用 Analyzer 信息。

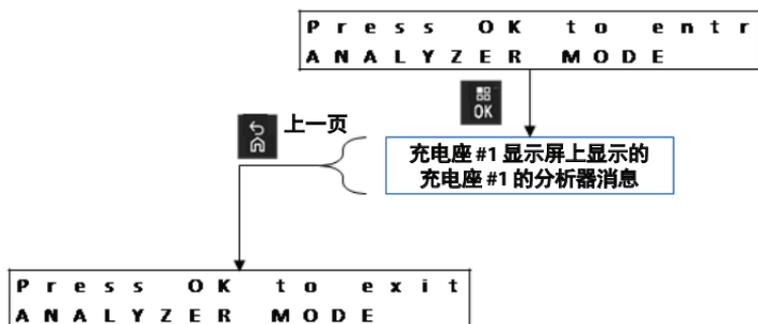

图 16：版本 V1.05 分析器模式菜单

## 版本 V1.11.01 分析器模式

发行软件版本 V1.11.01 后，Analyzer Mode 再次得到增强。对于只有充电座 #1 有显示屏的充电器，充电座 #1 菜单显示屏用于显示任何其他充电器充电座的信息。版本 V1.05 增强功能仍然适用。

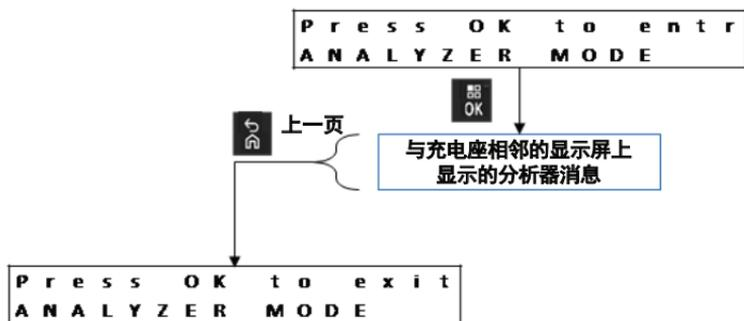

图 17: 版本 V1.11.01 分析器模式菜单

## 交换充电座中的电池

如果取下电池，然后将同一个电池或不同的电池插入同一个充电座中，则针对第二个电池显示的参数是针对第一个电池显示的相同参数。

例如，针对 IMPRES 2 或 IMPRES 电池显示 Battery IMPRES Cycles。从充电座中取下此电池。将另一个 IMPRES 2 或 IMPRES 电池插入到同一个充电座中。针对第二个电池显示的第一个参数显示 Battery IMPRES Cycles。

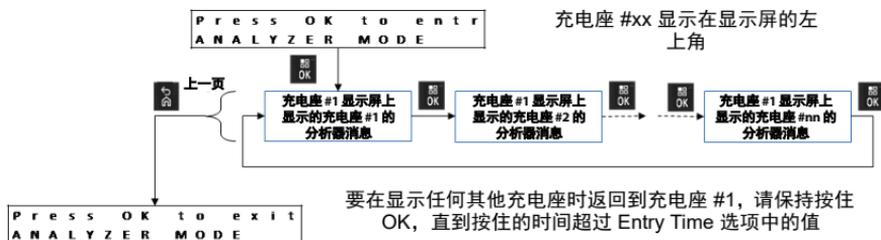
但是，第二个电池可能没有针对第一个电池显示的参数。在这种情况下，将针对第二个电池显示识别信息。

# IMPRES 2 电池

## 邻近充电座的显示屏



图 18: 与充电座相邻的显示屏的 IMPRES 2 电池 Analyzer Mode 菜单



## 充电座 #1 显示另一个充电座

充电座 #xx 显示在显示屏的左上角

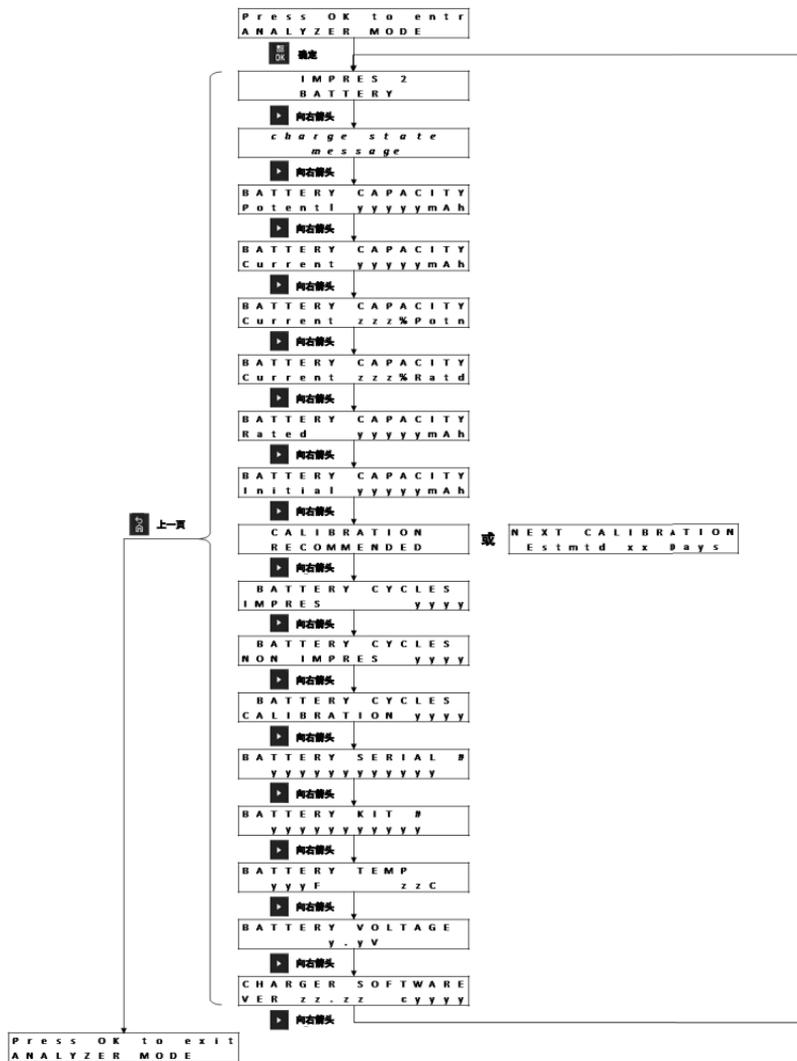

图 19: 另一个充电座 (非充电座 #1) 的 IMPRES 2 电池 Analyzer Mode 菜单

# IMPRES 电池

## 邻近充电座的显示屏

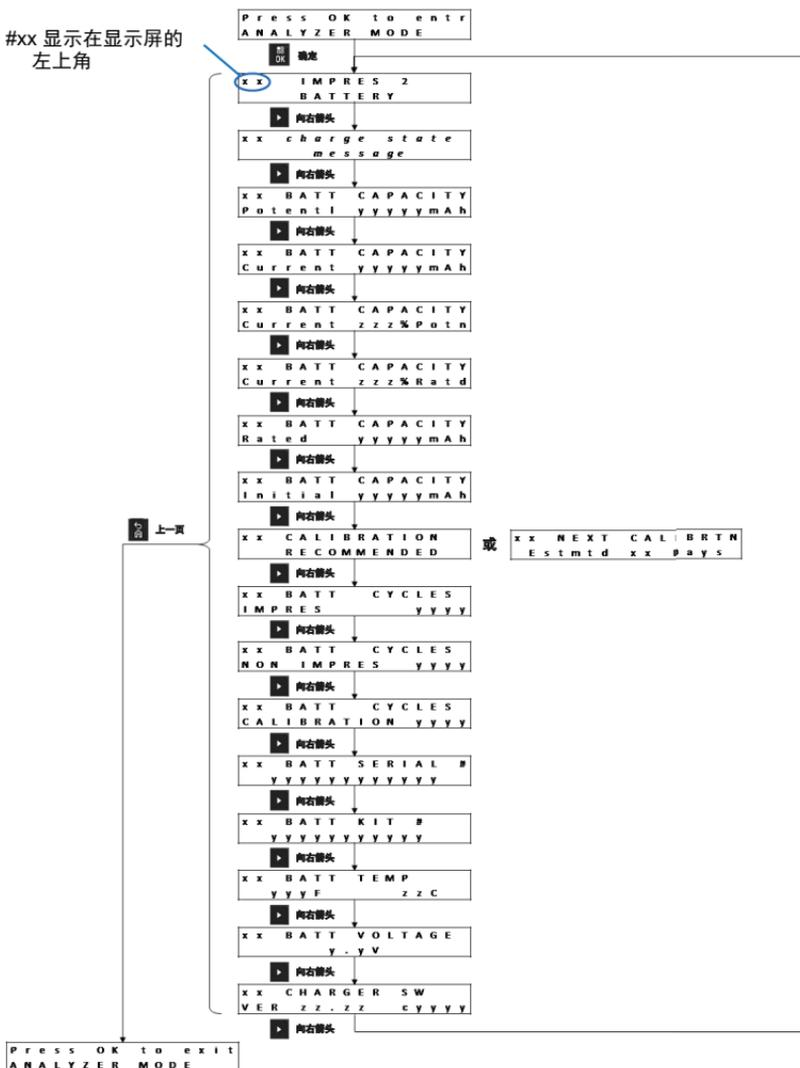

图 20: 与充电座相邻的显示屏的 IMPRES 电池 Analyzer Mode 菜单

## 充电座 #1 显示另一个充电座

充电座 #xx 显示在显示屏的  
左上角

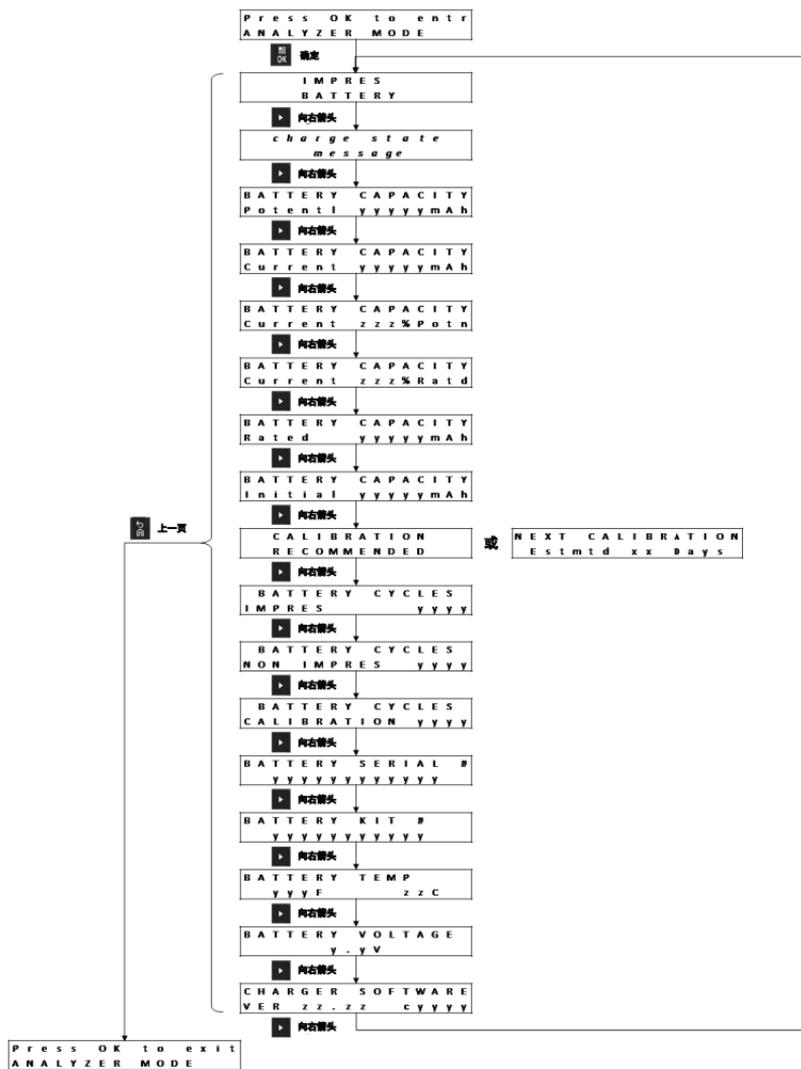

图 21: 另一个充电座（非充电座 #1）的 IMPRES 电池 Analyzer Mode 菜单

## 其他 Motorola Solutions 电池

### 邻近充电座的显示屏

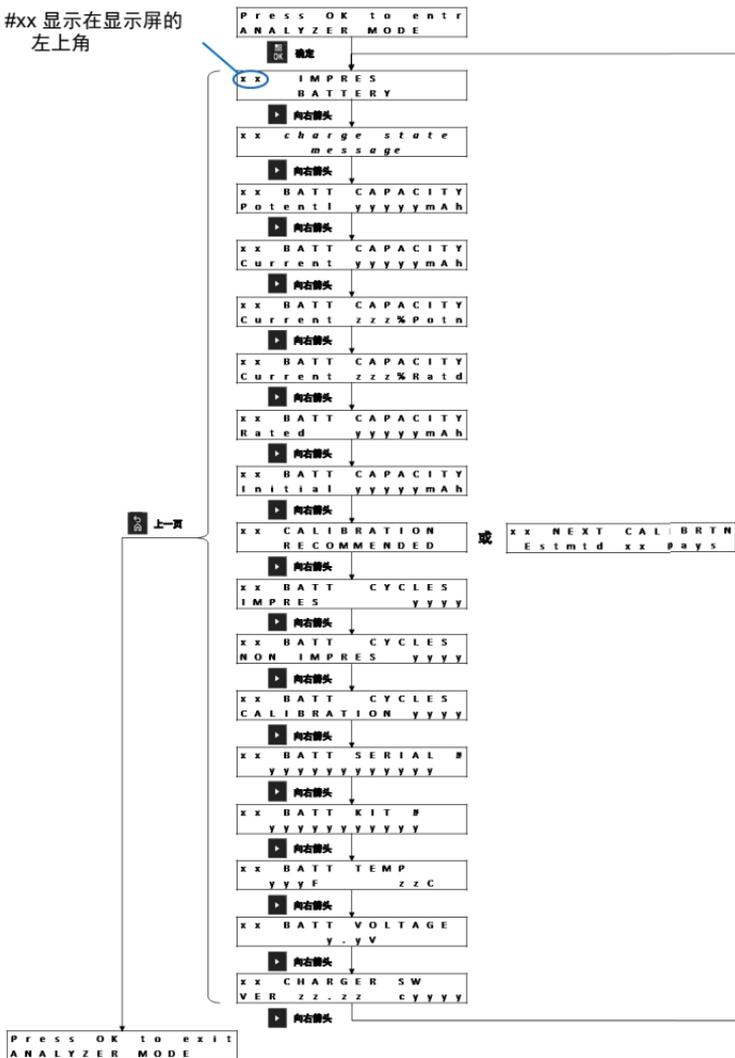

图 22: 与充电座相邻的显示屏的其他 Motorola Solutions 电池 Analyzer Mode 菜单

## 充电座 #1 显示另一个充电座

充电座 #xx 显示在显示屏的  
左上角

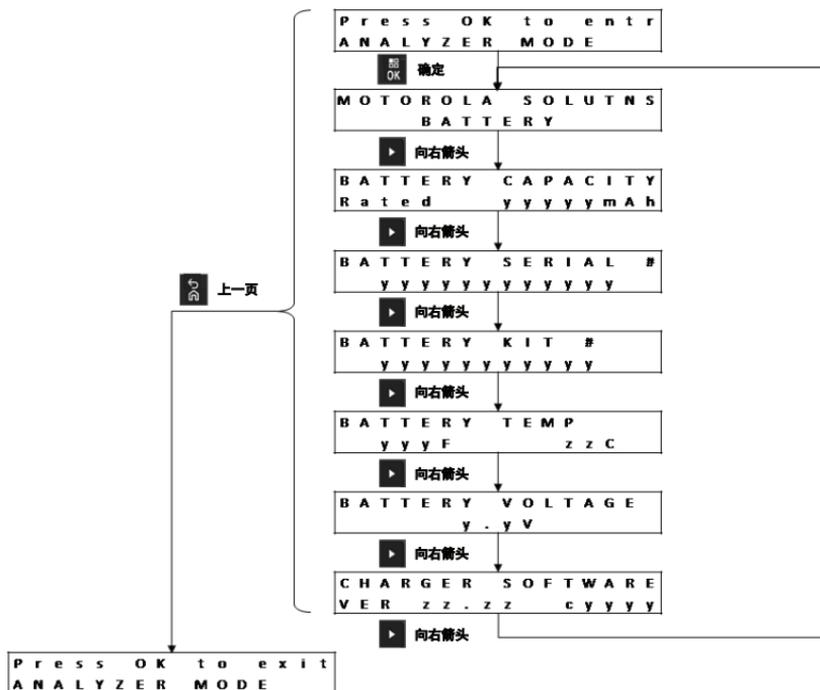

图 23: 另一个充电座（非充电座 #1）的其他 Motorola Solutions 电池 Analyzer Mode 菜单

## 未知电池

### 邻近充电座的显示屏

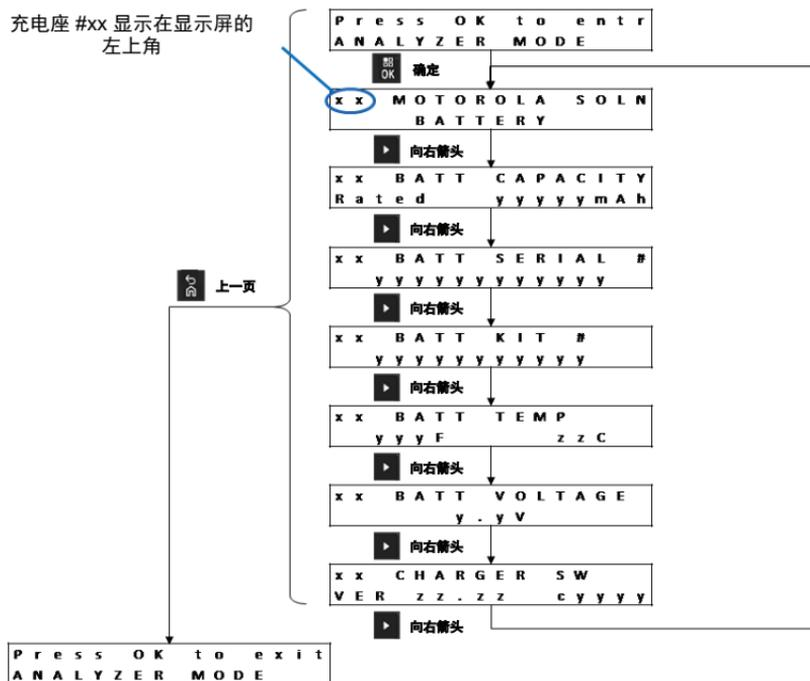

图 24：与充电座相邻的显示屏的未知电池 Analyzer Mode 菜单

### 充电座 #1 显示另一个充电座

充电座 #xx 显示在显示屏的  
左上角

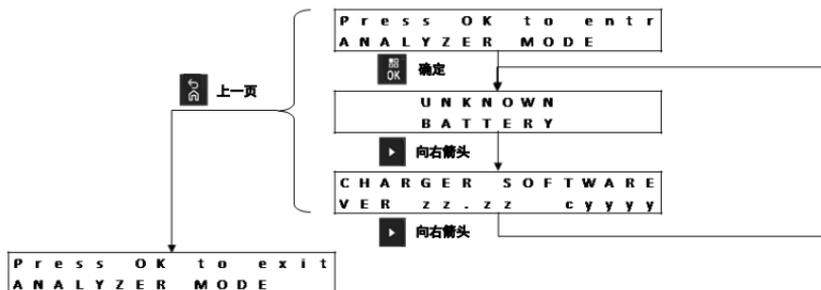

图 25：另一个充电座（非充电座 #1）的未知电池 Analyzer Mode 菜单

## 空充电座

### 邻近充电座的显示屏

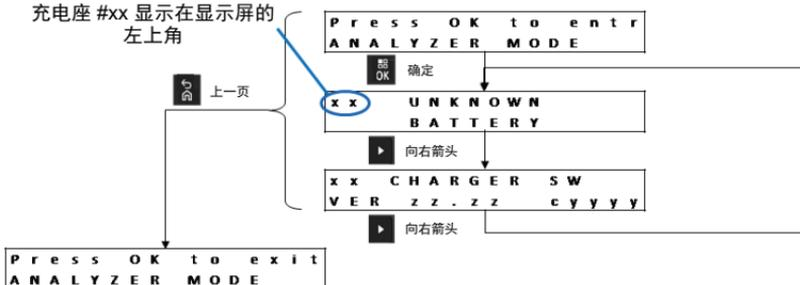

图 26：与显示屏相邻的空充电座的 Analyzer Mode 菜单

### 充电座 #1 显示另一个充电座

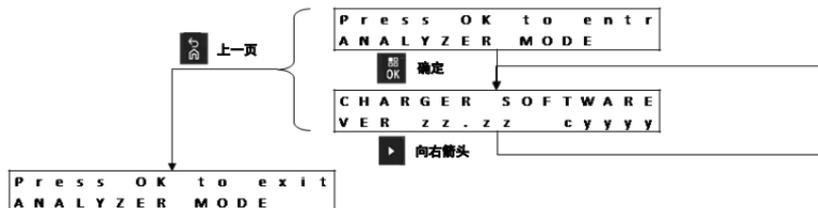

图 27：空充电座（非充电座 #1）的 Analyzer Mode 菜单

## 充电器状态消息

某些 IMPRES 2 电池配有睡眠模式。在 Ship Lithium、xx% Long-Term Storage 或 75% Long-Term Storage 结束时，会将配有睡眠模式的电池置于睡眠模式。Analyzer Mode 中的电量状态消息允许您检查处于睡眠状态的电池的电量状态。

表 21：Ship Lithium 已启用并且电池已完成 Ship Lithium 充电

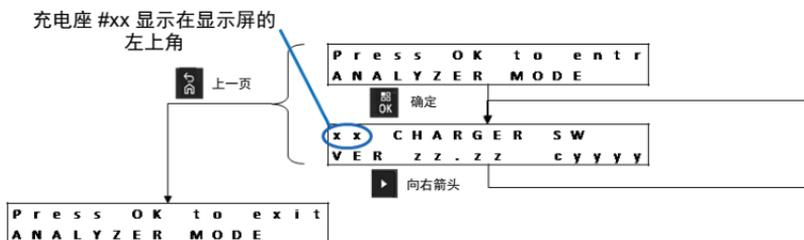
邻近充电座的显示屏	充电座 #1 显示另一个充电座
SHIP LI SLEEP xxxx% Rated Cap	xx SHIP LI SLEEP xxxx% Rated Cap

**表 22: xx% Long-Term Storage 已启用, 并且电池已完成 xx% Long-Term Storage 充电**

邻近充电座的显示屏	充电座 #1 显示另一个充电座
STORAGE SLEEP xxx% Rated Cap	xx STORAGE SLEEP xxx% Rated Cap

例如, 如果启用了 xx% Long-Term Storage 并且电池在另一个充电器中完成了 75% Long-Term Storage 充电, 则不会显示充电状态消息。

## 充电器重新编程

充电器重新编程需要使用标准 USB 电缆将通信模块连接到计算机。使用 IMPRES Battery Fleet Management 系统启动充电器重新编程, 充电器将显示以下消息。

在重新编程之前, 从充电器的充电座中取出电池:

```
REPROGRAMMING
REMOVE BATTERIES
```

充电器的所有充电座均为空:

```
REPROGRAMMING
WAITING FOR DATA
```

重新编程数据正在下载:

```
REPROGRAMMING
Progress yyy%
```

对于有显示屏与每个充电座关联的充电器, 百分比值就是成功下载到与显示屏关联的充电座的数据的百分比。对于只有一个显示屏 (充电座 #1) 的充电器, 百分比值是成功下载所有充电座的数据的百分比。

重新编程在所标识的充电座中失败:

```
REPROGRAMMING
POCKET#xx FAILED
```

标识的充电器充电座将使用以前的软件开始正常运行。

重新编程数据下载完成。充电器正在完成重新编程过程。

```
IMPRES 2
CHARGER
```



重新编程过程已成功完成。

REPROGRAMMING  
COMPLETE

充电器将使用新下载的软件开始正常运行。用户定义的设置在完成充电器重新编程后会保留下来。

## 充电器故障排除

表 23：故障排除：正常充电

问题	如何处理 ...
充电座 LED 指示灯不呈绿色闪烁约 1 秒钟，等待充电器开机。	<p>确保将电源线牢固插入充电器并将充电器插入合适的交流电源插座。</p> <p>确保电源插座可以正常供电。</p> <p>检查保险丝，必要时予以更换。</p>
电池或对讲机插入充电座中，但充电座 LED 指示灯保持熄灭，并且未在邻近的显示屏上识别电池。	<p>如果充电座不是充电座 #1 并且启用了 Power Saver，请按菜单按钮。</p> <p>请参见下文。</p>
闪烁红色 LED 指示灯和显示屏（如果可用）  显示： NOT CHARGEABLE REMOVE & REINSERT 或者 Motorola Solutions 电池在充电座中，但显示屏（如果可用）显示： UNKNOWN BATTERY	<p>从充电座中取出电池或对讲机。</p> <p>检查电池和充电器充电座上的电气触点是否存在污垢、腐蚀或物理损坏。</p> <p>确认电池是获得授权的 Motorola Solutions 的电池。其他类型的电池不能使用此充电器进行充电。</p> <p>使用干布清洁电池的电气触点。</p> <p>断开充电器的电源连接，然后使用干布清洁充电座的电气触点。</p> <p>尝试更换电池。如果故障不再存在，则停止使用有故障的电池。</p> <p>如果更换电池后故障仍然存在，则停止使用该充电器。</p>
校准结束时显示交替的红色 / 绿色 LED 指示灯。 	<p>IMPRES 2 或 IMPRES 电池的使用寿命可能即将结束。电池可以使用，但可用容量可能不适合用于长班次的高负荷使用。</p> <p>仅适用于 APX NEXT XN 电池：电池已暴露在高温环境下超过十分钟。建议移除电池，停止使用。</p>

表 23: 故障排除: 正常充电 (续)

问题	如何处理 ...
在将电池插入充电器时显示交替的琥珀色 / 绿色 LED 指示灯约 4 秒钟。 	IMPRES 2 或 IMPRES 电池需要校准 / 修复。在下一个合适的机会, 将电池放入已启用校准的 IMPRES 2 充电器中, 并允许充电器完成校准 (呈绿色长亮)。
在 Analyzer Mode 中, 充电座 #1 可以显示另一充电座。	充电器无法检测到至少其中一个其他充电座的显示屏。

表 24: 故障排除: Long-Term Storage 充电

问题	如何处理 ...
闪烁红色 LED 指示灯和显示屏 (如果可用) 显示: WRONG BATT TYPE CANNOT LT STORE 或 CANNOT DISCHARGE CANNOT LT STORE 	从充电座上取下电池。确认电池未安装在对讲机中。 确认电池是 IMPRES 2 或 IMPRES 电池。其他电池将出现故障。 使用干布清洁 IMPRES 2 或 IMPRES 电池的电气触点。 断开充电器的电源连接, 然后使用干布清洁充电座的电气触点。 尝试用另一个 IMPRES 2 或 IMPRES 电池更换该电池。如果故障不再存在, 则停止使用有故障的 IMPRES 2 或 IMPRES 电池。 如果更换 IMPRES 2 或 IMPRES 电池后故障仍然存在, 则停止使用该充电器。
闪烁红色 LED 指示灯和显示屏 (如果可用) 显示: STORE INCOMPLETE Low Capacity:yy% 	IMPRES 2 或 IMPRES 电池的潜在容量可能少于 Long-Term Storage 选项。电池的使用寿命可能即将结束。
闪烁红色 LED 指示灯和显示屏 (如果可用) 显示: RADIO POCKET CANNOT LT STORE 或 CHARGING POCKET CANNOT LT STORE 	充电器充电座不是用于为电池充电的标准充电座 (通过充电器和电池之间的电气触点)。 <ul style="list-style-type: none"> <li>对讲机充电座是一种特殊的充电座, 需要将电池安装在对讲机中, 电池上没有外部触点, 通过对讲机上的电气触点为电池充电。</li> <li>充电座是将充电器的电能用于特殊用途的充电座, 例如 USB 充电端口。</li> </ul> 将电池安装到标准充电座或使用标准充电座更换对讲机充电座或充电座。

表 25：故障排除：Ship Lithium 充电

问题	如何处理 ...
闪烁红色 LED 指示灯和显示屏（如果可用）显示： WRONG BATT TYPE CANNOT SHIP LI 	从充电座上取下电池。确认电池未安装在对讲机中。 验证电池是 IMPRES 2、IMPRES 或其他授权的 Motorola Solutions 锂离子电池。其他电池将出现故障。 使用干布清洁 IMPRES 2、IMPRES 或其他授权的 Motorola Solutions 锂离子电池的电气触点。 断开充电器的电源连接，然后使用干布清洁充电座的电气触点。 尝试使用 IMPRES 2、IMPRES 或其他授权的 Motorola Solutions 锂离子电池更换该电池。如果故障不再存在，则停止使用有故障的 IMPRES 2、IMPRES 或其他授权的 Motorola Solutions 锂离子电池。 如果更换 IMPRES 2、IMPRES 或其他授权的 Motorola Solutions 锂离子电池后故障仍然存在，则停止使用该充电器。
闪烁红色 LED 指示灯和显示屏（如果可用）显示： SHIP INCOMPLETE Low Capacity:yy% 	原装 Motorola Solutions 锂离子电池的潜在容量可能会少于 Ship Lithium 限制。电池的使用寿命可能即将结束。
闪烁红色 LED 指示灯和显示屏（如果可用）显示： RADIO POCKET CANNOT LT STORE 或 CHARGING POCKET CANNOT SHIP LI 	充电器充电座不是用于为电池充电的标准充电座（通过充电器和电池之间的电气触点）。 <ul style="list-style-type: none"> <li>• 对讲机充电座是一种特殊的充电座，需要将电池安装在对讲机中，电池上没有外部触点，通过对讲机上的电气触点为电池充电。</li> <li>• 充电座是将充电器的电能用于特殊用途的充电座，例如 USB 充电端口。</li> </ul> 将电池安装到标准充电座或使用标准充电座更换对讲机充电座或充电座。

## IMPRES Battery Fleet Management 系统

IMPRES Battery Fleet Management 软件自动从插入到 IMPRES 充电器的 IMPRES 或 IMPRES 2 电池中收集关键数据。关键数据包括电池寿命、容量、充电历史记录、校准/修复历史记录、制造日期和投入使用的日期。IMPRES Battery Fleet Management 软件可分析电池数据、显示电池性能状态并且建议更换电池的时间。因此，您可以快速高效地确定是否将电池重新部署给要求不高的用户，何时购买新的更换电池，或者何时搜索缺失的电池。

IMPRES Battery Fleet Management 可提供电池的关键信息：

- 当电池容量低于可接受的容量时。
- 帮助确保用户具有完整工作轮班所需的足够容量。
- 识别低容量电池，以便将它们停用。
- 避免意外的停机和工作中断。
- 避免过早弃用电池的浪费。
- 确认以最优方式分配和使用充电器。

IMPRES Battery Fleet Management 应用软件可从单站点扩展到多站点网络系统，如图 28 中所示。IMPRES Battery Fleet Management 系统支持：

- 一个系统管理员服务器
- 19 个远程客户端
- 每个客户端 25 个 IMPRES 充电器或 IMPRES 电池读取器
- 在同一个位置或地理分散的区域中的 25,000 块 IMPRES 电池（整个系统的电池总数不能超过 25,000）。

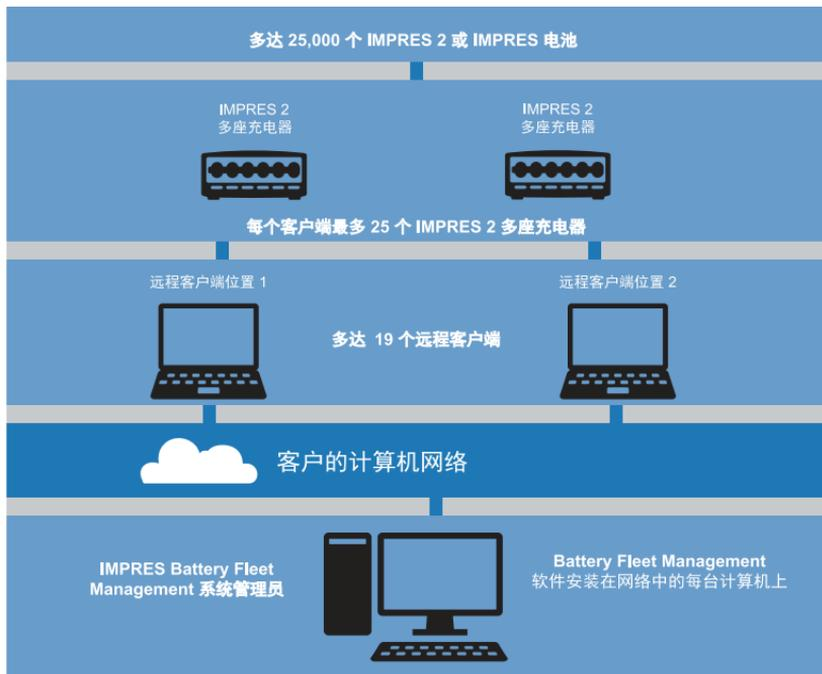

**图 28：**通过网络充电器进行的 IMPRES Battery Fleet Management

IMPRES Battery Fleet Management 包含三个主要组件：

- 应用软件。
- 软件许可证密钥。
- USB 电缆，用于将 IMPRES 2 充电器、IMPRES 2 通信模块、IMPRES 充电器接口装置 (CIU) 或 IMPRES 电池数据读取器连接到托管远程客户端的计算机。

使用现有报告自定义新报告，以查看与您的组织最相关的信息。数据存储在您的数据库中，可导出至 Excel™ 文件或进行打印。IMPRES Battery Fleet Management 软件将记录和整理数据，使您可以：

- 查看整个电池组的状态快照。
- 评估电池是否满足您的性能标准。
- 确定电池是否已接近其使用寿命上限。
- 决定购买新电池的准确时间。
- 获得丢失电池报告。
- 优化您的充电器利用率。
- 监控系统中的所有设备。

Serial Number	Alias	Group	Battery Family	Kit Number	Chemistry	Free	Rated Capacity	Potential Capacity	Date of Prod Use
10100001854759	Sam	Building 1	XTS 3000/3000/2000	HW060110	NaCl	No	1323	1391	8/1/2009
1010000185480	Missi	Security	APR	WNTN7973A	NaOH	No	2100	2480	3/21/2008
1010000185488	Michael	Security	APR	WNTN7973A	NaOH	Yes	2000	1400	2/16/2007
1010000283511	Phil	Administration	HT100/PRO Series	HW06028A	NaCl	No	1330	1240	3/4/2009
1010000283522	Missi	Building 1	XTS 3000/3000/2000	WNTN4078B	NaOH	Yes	2100	2360	8/24/2008
1010000283490	Stacey	Building 1	XTS 2800, XTS/MT/HR ES00	WNTN7954A	Li-Ion	No	2000	1940	2/26/2008
1010000348811	Active	None	Label	HW060110	NaCl	No	2000	1600	8/5/2009
1010000348719	Mark	Building 2	XTS 2800, XTS/MT/HR ES00	WNTN7954A	Li-Ion	No	2000	1940	8/11/2008
1010000388311	Diane	Building 2	XTS 2800, XTS/MT/HR ES00	WNTN7954A	Li-Ion	No	2000	1940	8/21/2008
1010000384120	Bob	None	Label	HW060110	NaCl	Yes	2000	1600	3/20/2009
1010000320211	Carol	Administration	HT100/PRO Series	HW06028A	NaOH	Yes	1400	1330	1/11/2008
1010000411807	Pat	Building 1	XTS 3000/3000/2000	WNTN4458B	NaOH	Yes	1700	1207	3/21/2008
1010000411200	Jane	Building 1	XTS 3000/3000/2000	HW060110	NaCl	No	1323	1082	8/2/2009
101000039303	Bill	Security	APR	WNTN7973A	Li-Ion	Yes	1620	2911	7/21/2008
101000039302	Frank	Security	APR	WNTN7973A	NaOH	No	2100	1491	3/11/2008
101000048327	Mark	Building 2	XTS 3000/3000/2000	WNTN7423A	Li-Ion	Yes	2000	2004	3/18/2009
101000042120	Eric	Maintenance	HC107180	HW06073A	Li-Ion	No	2120	2120	2/28/2008
101000042878	Mary	Administration	HT100/PRO Series	HW06028A	NaCl	No	1300	1100	7/10/2009
101000042891	Phil	Building 1	APR	WNTN7973A	NaOH	No	2100	1491	8/2/2008
1010000409842	Tom	Security	APR	WNTN7973A	Li-Ion	Yes	1620	2911	1/18/2008
1010000498127	Bill	Maintenance	HT100/PRO Series	HW06028A	NaCl	No	1300	1100	8/5/2009
1010000484211	Sam	Building 2	XTS 3000/3000/2000	HW06028A	NaOH	No	2000	2070	8/6/2007
1010000424139	Paul	Administration	HC107180	HW06065A	Li-Ion	Yes	1400	866	8/11/2008
1010000742323	Frank	Building 1	APR	WNTN7973A	NaOH	Yes	2000	1380	7/20/2009
1010000708013	Tom	Security	HC107180	HW06065A	Li-Ion	Yes	1400	866	8/11/2008
1010000705013	Amy	Maintenance	APR	WNTN7973A	NaOH	No	2100	1444	3/11/2008
1010000707426	Garoff	Building 2	HT100/PRO Series	HW06028A	NaOH	No	1800	1242	10/11/2007
1010000703018	Gene	Security	XTS 3000/3000/2000	WNTN7973A	Li-Ion	No	1410	2840	8/11/2008
1010000703220	Bob	Administration	APR	WNTN7973A	NaOH	No	2100	1444	3/17/2008
1010000707761	Mark	Building 1	HC107180	HW06065A	Li-Ion	No	2000	1030	10/11/2007

图 29：活动电池报告



图 30：对讲机系列使用的电池





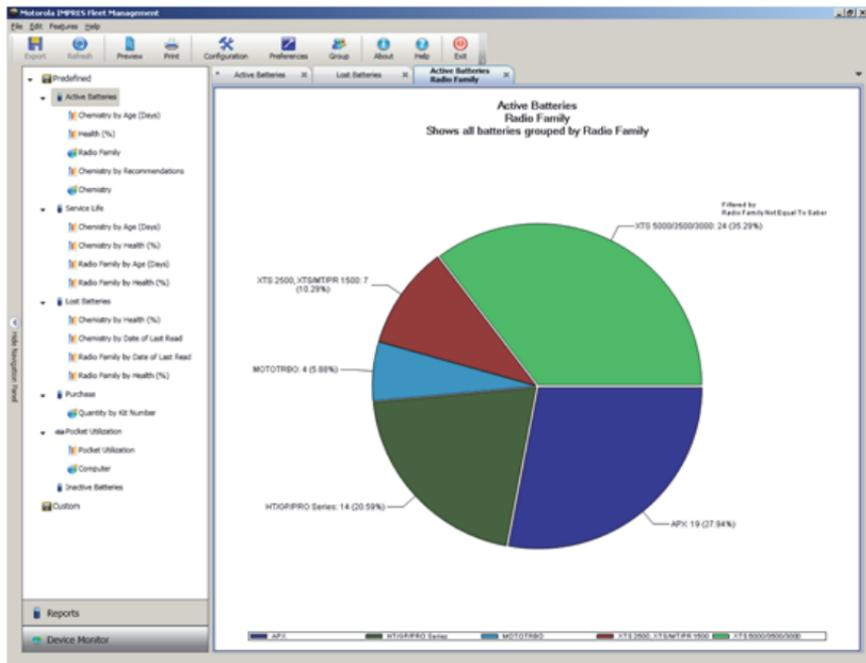

图 32：充电器的充电座利用率

## 多座充电器墙壁安装支架

墙壁安装支架（部件号：0705559L01）可用于多座充电器。通过联系当地的经销商可订购此物品。安装方法显示如下。

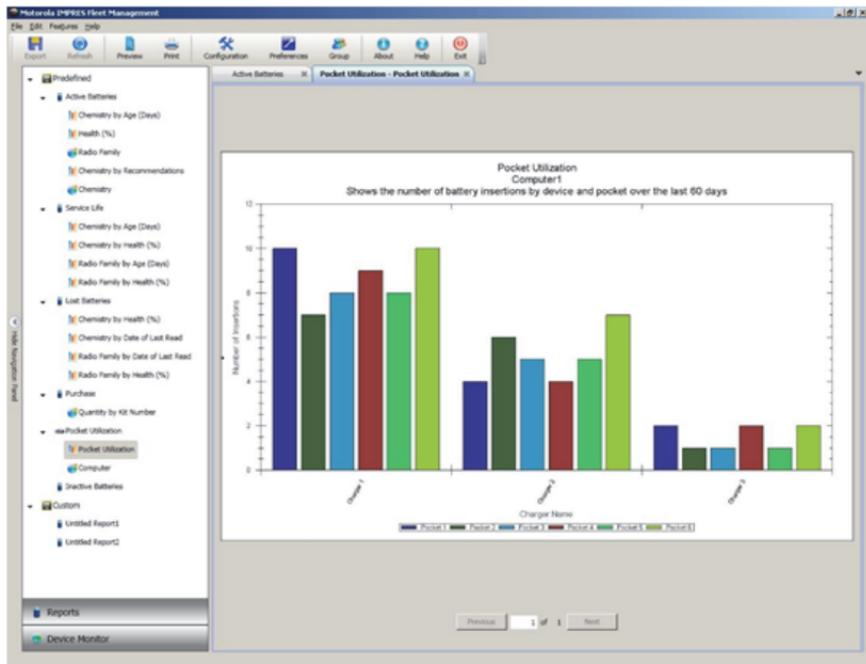

### 警告

- 此款墙壁安装支架必须由经过了培训、拥有丰富经验的技术人员进行安装。由非专业技术人员安装产品非常危险，可能会造成产品损坏或人身伤害。
- 请勿将产品安装在无法支撑其重量的地方。如果安装墙壁支架处的承重力不够，则产品可能会掉下来并导致人身伤害。
- 切勿将产品安装在容易振动、移动或受到冲击的结构上。



图 33：支架安装孔和锁扣位置

## 将多座充电器安装到墙壁支架上

1. 将墙壁安装支架置于所需位置，并在墙面上标记安装孔的位置。

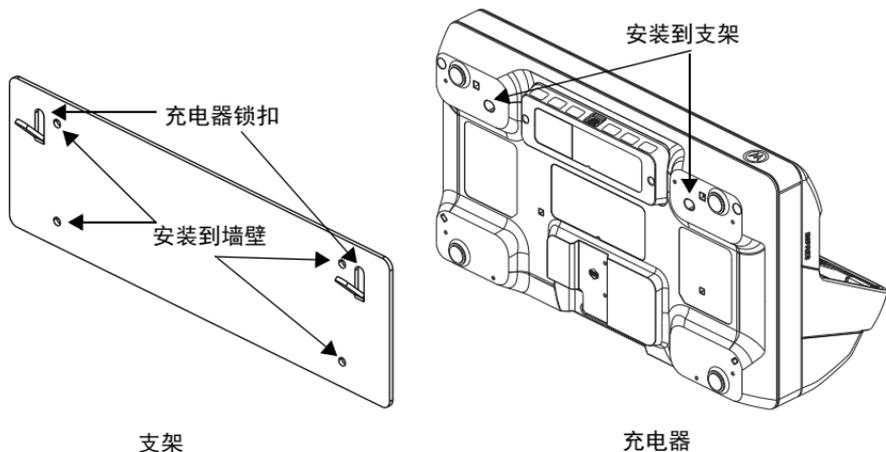

警告

切割、钻孔或安装固定螺钉之前，确保安装表面后部区域没有电线、电缆和管道。

2. 根据产品将安装的墙壁的材料，使用所需的适用安装硬件将支架安装在墙壁上。在墙面上标记的安装孔位处钻孔。
3. 通过安装孔将安装硬件牢牢安装在墙壁支架上，将墙壁支架固定到位。

**注意：**建议在木龙骨和实心平整的混凝土/砖墙上使用 10-16 个 1.5 英寸自攻螺钉和垫圈（未随附）。

4. 将多座充电器挂在墙壁支架上。



图 34：充电器安装在墙壁支架上

# 주요 안전 지침

## 이 지침을 반드시 보관하십시오.

이 문서는 주요 안전 지침 및 작동 지침을 수록하고 있습니다. 지침을 주의 깊게 읽으신 후 향후 참고 자료로 활용하기 위해 보관하여 주십시오.

배터리 충전기를 사용하기 전에 (1) 충전기, (2) 배터리, (3) 배터리를 사용하는 무전기에 대한 지침과 주의사항을 모두 숙지하십시오.



경고

1. 전원 코드에 대한 손상의 위험을 줄이기 위해, **AC 콘센트** 또는 충전기를 분리할 때 코드 대신 플러그를 잡고 당기십시오.
2. 연장 코드는 꼭 필요하지 않은 이상 사용하지 말아야 합니다. 부적절한 연장 코드를 사용할 경우 화재나 감전의 위험이 있습니다. 연장 코드의 사용이 불가피하다면 **최장 2.0m(6.5ft) 길이의 18AWG 규격 코드 및 최장 3.0m(9.8ft) 길이의 16AWG 코드를 사용하십시오.**
3. 화재, 감전 또는 부상의 위험을 줄이기 위해, 충전기가 고장 났거나 손상된 채로 사용하지 마십시오. 공인된 **Motorola Solutions** 서비스 담당자에게 가져가십시오.
4. 충전기를 분해하지 마십시오. 충전기를 분해하는 경우 감전 또는 화재의 위험이 있습니다. 유일한 수리 가능/교체 부품은 **NNTN9212 및 NNTN9213** 포켓 인서트입니다. **APX-Series IMPRES 2** 멀티 유닛 충전기 포켓 삽입 키트 **MN005697A01**의 지침에 따르십시오.
5. 유지보수나 청소 시 감전될 수 있으므로 항상 사전에 **AC 콘센트**에서 충전기 전원 공급 장치를 분리하도록 하십시오.
6. 부상 위험을 줄이려면 표 2에 나열된 **Motorola Solutions** 인증 충전식 배터리만 사용하십시오. 다른 배터리는 폭발의 위험이 있으며 부상 및 손상이 발생할 수 있습니다.
7. **Motorola Solutions**에서 권장하지 않는 액세서리를 사용하는 경우, 화재, 감전 또는 부상의 위험이 있습니다.

## 작동 안전 지침

- 이 장비는 실외에서 사용하기에는 적절치 않습니다. 건조한 장소/상태에서만 사용하십시오.
- 충전기의 주변 온도는 최고 **40°C(104°F)**를 넘지 않아야 합니다.
- 무전기가 충전 포켓에 있을 경우 **Wi-Fi** 사용 등과 같이 데이터를 무선으로 송신 중일 때에만 무전기를 켜십시오. 그렇지 않은 경우 무전기를 끄십시오.
- 충전기는 표 3에 제시된 적절한 전원 공급 장치에만 연결하십시오.
- 전원 코드가 연결되어 있는 **AC** 콘센트는 가까운 곳에 있어야 하며 쉽게 닿을 수 있어야 합니다.
- 충전기에 연결되어 있는 전원 공급 장치 코드는 발에 밟히거나 걸려 넘어질 수 있는 곳, 물기가 있거나 손상이나 응력이 가해질 수 있는 곳을 피하여 설치해 주십시오.
- 제품에 명시된 대로 올바른 전압의 적절한 퓨즈가 장착된 유선 **AC** 콘센트에만 전원 코드를 연결하십시오.
- **AC** 콘센트로부터 전원 코드를 분리하여 선간 전압 연결을 해제하십시오.
- 사용 중인 인증된 멀티탭의 제한에 따라 **15A** 또는 **20A** 회로에 연결하는 충전기의 수는 적당한 수를 넘어서는 안 됩니다. 직렬 연결 멀티탭은 권장하지 않습니다. 회로 부하를 회로 정격의 **80%**보다 작게 제한합니다.
- **Motorola Solutions** 인증 포켓만 사용하십시오.

# 지원 모델

표 1: 지원 모델 및 설명

모델	설명
PS000029A01(일반) PS000029A04(유럽/영국) PS000029A06(한국)	충전기 재프로그래밍과 그룹 관리 기능이 있는 APX 1-디스플레이 IMPRES 2 멀티 유닛 충전기
PS000029A02(일반) PS000029A05(유럽/영국) PS000029A07(한국)	충전기 재프로그래밍과 그룹 관리 기능이 있는 APX 6-디스플레이 IMPRES 2 멀티 유닛 충전기
PS000029A03(유럽/영국) PS000029A08(한국)	충전기 재프로그래밍과 그룹 관리 기능이 있고 USB 액세서리 충전이 가능한 APX 6-디스플레이 IMPRES 2 멀티 유닛 충전기
PS000337A01(미국/북미/ 호주/뉴질랜드)	충전기 재프로그래밍과 그룹 관리 기능이 있는 APX NEXT 6-디스플레이 IMPRES 2 멀티 유닛 충전기

## Motorola Solutions 인증 배터리

APX-Series IMPRES 2 충전기는 표 2에 나열된 배터리를 충전합니다. 배터리는 무전기에 부착하거나 단독으로 충전할 수 있습니다.

표 2: Motorola Solutions 인증 배터리.

키트(PN)	설명
NNTN7033	IMPRES 리튬 이온 FM(HazLoc) IP67 4100mAh
NNTN7034	IMPRES 리튬 이온 IP67 4200mAh
NNTN7035	IMPRES 니켈 수소 FM(HazLoc) 산업용 2000mAh
NNTN7036	IMPRES 니켈 수소 FM(HazLoc) IP67 2000mAh
NNTN7037	IMPRES 니켈 수소 IP67 2100mAh
NNTN7038	IMPRES 리튬 이온 IP67 2900mAh
NNTN7573	IMPRES 니켈 수소 산업용 2100mAh
NNTN8092	IMPRES 리튬 이온 FM(HazLoc) 산업용 2300mAh
NNTN8182	IMPRES 리튬 이온 산업용 2900mAh
NNTN8921	IMPRES 2 리튬 이온 TIA4950(HazLoc) 산업용 IP67 3700mAh
NNTN8930	IMPRES 2 리튬 이온 TIA4950(HazLoc) 산업용 IP67 2700mAh
NNTN9087	IMPRES 2 리튬 이온 IP68 3800mAh

표 2: Motorola Solutions 인증 배터리. (계속)

키트(PN)	설명
NNTN9088	IMPRES 2 리튬 이온 DIVISION 2(HazLoc) 산업용 IP68 3800mAh
NNTN9089	IMPRES 2 리튬 이온 IP68 5650mAh
NNTN9090	IMPRES 2 리튬 이온 DIVISION 2(HazLoc) IP68 5650mAh
NNTN9126	IMPRES 2 리튬 이온 IP68 4400mAh
NNTN9127	IMPRES 2 리튬 이온 DIVISION 2(HazLoc) 산업용 IP68 4400mAh
PMNN4403	IMPRES 리튬 이온 IP67 2150mAh
PMNN4485	IMPRES 2 리튬 이온 산업용 IP67 2500mAh
PMNN4486	IMPRES 2 리튬 이온 산업용 IP67 3400mAh
PMNN4487	IMPRES 2 리튬 이온 산업용 IP67 4400mAh
PMNN4494	IMPRES 2 리튬 이온 산업용 IP67 5000mAh
PMNN4504	IMPRES 2 리튬 이온 DIVISION 2(HazLoc) 산업용 IP67 3400mAh
PMNN4505	IMPRES 2 리튬 이온 DIVISION 2(HazLoc) 산업용 IP67 4850mAh
PMNN4547	IMPRES 2 리튬 이온 TIA4950(HazLoc) 산업용 IP68 3100mAh
PMNN4573	IMPRES 2 리튬 이온 TIA4950(HazLoc) 산업용 IP68 4600mAh
PMNN4812	APX NEXT XN IMPRES 2 리튬이온 DIV 2(HAZLOC) IP68 3400mAh

## Motorola Solutions 인증 전원 공급 장치

표 3: Motorola Solutions 인증 전원 공급 장치

키트(PN)	설명
3087791G01	전원 코드, 미국/북미
3087791G04	전원 코드, 유럽
3087791G07	전원 코드, 영국/홍콩
3087791G10	전원 코드, 호주/뉴질랜드
3087791G13	전원 코드, 아르헨티나
3087791G16	전원 코드, 한국
3087791G20	전원 코드, 일본
3087791G22	전원 코드, 브라질
CB000460A01	전원 코드, 중국

# Motorola Solutions 인증 통신 모듈

표 4: Motorola Solutions 인증 통신 모듈

키트(PN)	설명
AS000013A01	IMPRES 2 충전기 재프로그래밍 및 배터리 그룹 관리 모듈
AS000012A02	IMPRES 2 충전기 재프로그래밍/배터리 그룹 관리 및 액세서리 충전 모듈

## 충전기, 포켓 및 통신 모듈

APX Series IMPRES 2™ 적응형 충전기 시스템은 완전 자동화된 배터리 관리 시스템입니다. 충전기에는 다음 기능이 탑재되어 있습니다.

- IMPRES 2, IMPRES™ 및 기타 인증받은 Motorola Solutions 배터리를 포함한 다양한 유형의 배터리를 수용하는 적응형 충전 기능.
- 독립형 배터리 또는 배터리가 장착된 무전기를 수용하는 포켓
- 빨간색/황색/녹색 LED로 표시되는 충전기 포켓 상태.
- 통신 모듈
  - 충전기 재프로그래밍
  - IMPRES 2 또는 IMPRES 배터리 데이터를 IMPRES 배터리 그룹 관리 시스템에 업로드
  - (별매품) 6개의 USB Type A 충전 포트, 각각의 USB 액세서리 충전에 0.5A 사용
- 키패드 메뉴
  - 충전기 설정
  - 배터리 분석
- 포켓 1번의 정보 디스플레이.
  - 다른 포켓의 디스플레이(선택 사항)
- 단독형 IMPRES 2 또는 IMPRES 배터리 장기 보관 준비 또는 단독형 Motorola Solutions 리튬 이온 배터리 배송 준비. 장기 보관 또는 리튬 이온 배송 준비가 완료되면 충전기에 배터리를 꽂아 두지 마십시오.
- 에너지 효율 기능
  - 소형 배터리 충전 시스템에 대한 캘리포니아 에너지 위원회의 장비 표준을 준수합니다. 충전기 포켓이 자동으로 절전 모드로 전환되었다가 사용자 동작에 응답하거나 포켓의 배터리를 충전하기 위해 켜집니다.
  - 유럽 대기 전류 한계(유럽 충전기 키트)를 준수합니다. 전원 절약 모드가 활성화되어 있을 때 일정 기간 동안 활동이 없으면 포켓 1번을 제외한 모든 충전기 포켓이 자동으로 꺼집니다. 아무 키패드 버튼이나 누르면 이러한 포켓이 다시 켜집니다.



- IMPRES 2 리튬이온 배터리 고속 충전.
- 빠른 충전 가능.
- 배터리 수명 주기 연장.

충전기에 장착되어 있을 때의 무전기 작동은 권장하지 않습니다.

충전 프로세스가 진행되는 동안 무전기를 작동하면 무전기 성능이 최소한으로 감소하고 배터리 충전 시간이 길어질 수 있습니다.

보정/리컨디셔닝 도중에는, 배터리가 완전히 방전되었다가 완전히 충전됩니다. 따라서 방전 단계에서 무전기가 꺼질 수 있습니다. 무전기가 연결되지 않거나 연결된 무전기가 꺼진 상태에서 배터리를 보정하는 것이 좋습니다.

## IMPRES 2 및 IMPRES 배터리 및 충전기

### 특징과 장점

IMPRES 2 에너지 솔루션은 Motorola Solutions에서 개발한 고급 3중 화학 에너지 시스템입니다. 이 시스템에는 다음이 포함됩니다.

- IMPRES 2 및 IMPRES 배터리
- IMPRES 2 적응형 충전기
- IMPRES 무전기

주기적으로 배터리 보정/리컨디셔닝이 이루어지는 IMPRES 2 적응형 충전기를 사용하여 IMPRES 2 또는 IMPRES 배터리를 충전하면 다음과 같은 이점을 얻을 수 있습니다.

- 배터리 수명 주기를 연장합니다.
- 배터리 용량을 측정하고 현재의 배터리 충전 상태를 파악할 수 있으므로 사용자에게 사용 시간을 효율적으로 표시할 수 있습니다.
- IMPRES 2 또는 IMPRES 배터리 사용 패턴을 모니터링합니다.
- IMPRES 2 또는 IMPRES 배터리에 저장된 패턴 정보를 업데이트합니다.
- 필요 시에만 자동 보정/리컨디셔닝을 수행합니다.
- 배터리가 포켓에 얼마나 있었는지에 상관없이 IMPRES 2 또는 IMPRES 배터리 가열을 최소화합니다.
- 주기적으로 충전기 포켓에 저장된 배터리를 "충전"하므로 사용자가 바로 사용할 수 있도록 준비성을 향상시킵니다.
- 니켈 배터리 메모리 효과를 제거하여 배터리 수명 주기를 유지하기 위해 특수 장비를 구입하거나 담당자를 훈련시킬 필요가 없습니다.

이 특허 받은 고유한 시스템을 사용하면 IMPRES 2 또는 IMPRES 배터리 사용을 추적 및 기록하거나, 수동 보정/리컨디셔닝을 수행하거나, 충전 완료 시 충전기에서 배터리를 분리할 필요가 없습니다.

## IMPRES 2 또는 IMPRES 배터리 초기화

전체 IMPRES 2 또는 IMPRES 기능을 사용하려면 충전기로 새 IMPRES 2 또는 IMPRES 배터리를 초기화해야 합니다. 충전기는 자동으로 새 IMPRES 2 또는 IMPRES 배터리를 감지한 다음에 자동으로 초기화를 시작합니다. 초기화는 IMPRES 2 또는 IMPRES 배터리의 최초 IMPRES 배터리 보정/리컨디셔닝입니다. 이 작업은 두 단계 프로세스입니다. 첫 번째 단계는 배터리 방전으로, **황색으로 켜진 LED**로 표시합니다. 두 번째 단계는 완전 충전으로, **녹색으로 켜진 LED**로 표시합니다. 배터리의 충전 상태 및 용량에 따라 이 프로세스를 완료하는 데 12시간 이상이 걸릴 수 있습니다. 이 두 단계 중 어느 단계라도 중단되면 다음 충전 시까지 초기화 작업이 지연됩니다.

## IMPRES 2 또는 IMPRES 포켓-포켓

IMPRES 2 또는 IMPRES 배터리를 충전할 때 IMPRES 2 또는 IMPRES 충전기는 배터리 메모리 안에 충전 정보를 기록합니다. IMPRES 2 또는 IMPRES 배터리가 한 IMPRES 2 또는 IMPRES 충전기 포켓에서 분리되고 30분 안에 다르거나 같은 IMPRES 2 또는 IMPRES 충전기 포켓에 삽입되면 충전이 중단된 지점에서 충전이 재개됩니다. 이 기능은 배터리 과충전을 막고 수명 주기 손실을 최소화합니다. 이것은 특히 니켈 배터리를 충전할 때 중요합니다.

## 자동 IMPRES 2 또는 IMPRES 배터리 보정/리컨디셔닝

IMPRES 2 충전기는 IMPRES 2 또는 IMPRES 배터리 상태를 자동으로 측정합니다. 측정된 상태에 따라, 충전기는 자동으로 배터리를 보정/리컨디셔닝합니다. 방전 단계나 완전 충전 단계 중 어느 단계라도 중단되면 다음 충전 시까지 보정 작업이 지연됩니다.

충전기 설정 모드를 사용하여 보정/리컨디셔닝을 활성화 또는 비활성화합니다. 비활성화되고 IMPRES 2 또는 IMPRES 배터리에 보정/리컨디셔닝이 필요한 경우, 배터리 삽입 시 및 배터리 충전 후 LED가 **황색/녹색으로 교대로 깜박**입니다.

**참고:** IMPRES 2 또는 IMPRES 배터리는 자동 보정/리컨디셔닝을 위해 30분 이상 충전기 포켓 외부에 있어야 합니다.

## 자체 보정 및 리컨디셔닝이 가능한 IMPRES 배터리



주의: 배터리 라벨에 이 아이콘이 있는 IMPRES 2 배터리는 이 IMPRES 2 충전기(소프트웨어 버전 V2.05 이상)에 도킹할 때 주기적으로 보정 및 리컨디셔닝할 필요가 없습니다.

**참고:** 충전기가 항상 최신 펌웨어로 업데이트되었는지 확인하십시오. MSI Charger Reprogrammer 애플리케이션 패키지는 Motorola 온라인(MOL) 또는 Motorola Solutions 웹사이트에서 다운로드할 수 있습니다.

### 펌웨어 업데이트

**참고:** 모든 IMPRES Gen 1 및 Gen 2 장치나 충전기에 적용됩니다. 여기에는 충전기 인터페이스 유닛(CIU), 배터리 데이터 판독기(BDR), 싱글 유닛 충전기(SUC), 듀얼 유닛 충전기(DUC), 멀티 유닛 충전기(MUC)가 포함됩니다.

IMPRES 장치 또는 충전기를 새 버전으로 업그레이드하기 전에 삽입된 모든 배터리를 대상 장치나 충전기에서 제거합니다.

1. USB를 사용하여 장치 또는 충전기를 컴퓨터에 연결합니다. 연결된 장치나 충전기는 MSI Charger Reprogrammer의 기본 창에 표시됩니다.

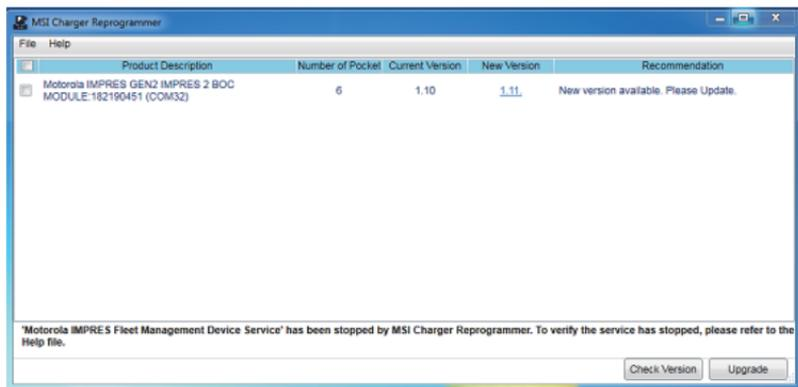

2. 버전 확인을 클릭하여 MSI 서버에서 사용 가능한 최신 버전을 찾습니다.

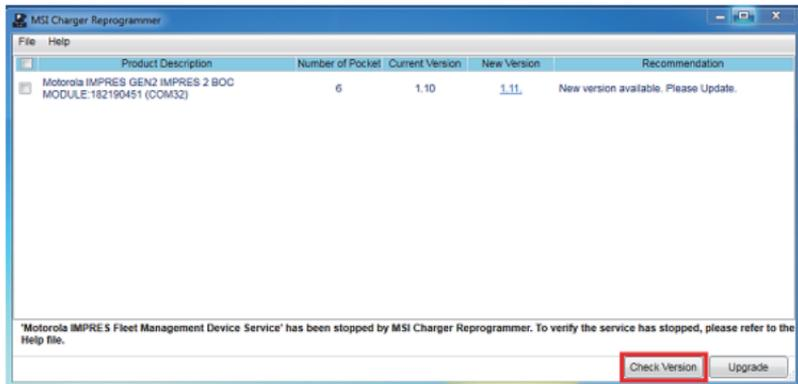

3. 업데이트가 필요한 장치나 충전기를 선택합니다.

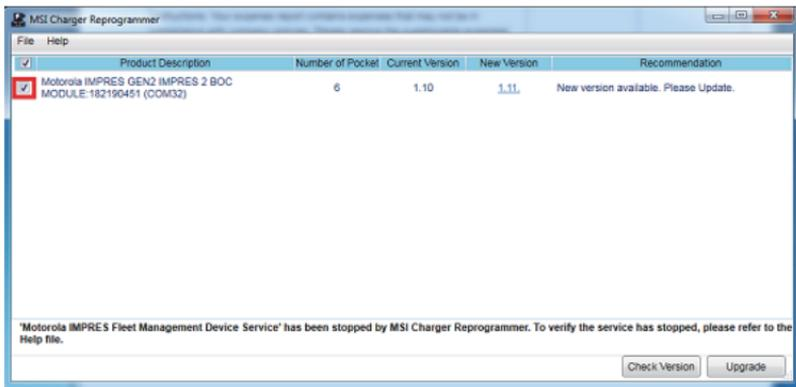

**참고:** 이미 최신 펌웨어 버전으로 업데이트된 장치나 충전기는 선택할 수 없습니다.

4. 펌웨어 업그레이드를 시작하려면 업그레이드를 클릭합니다.

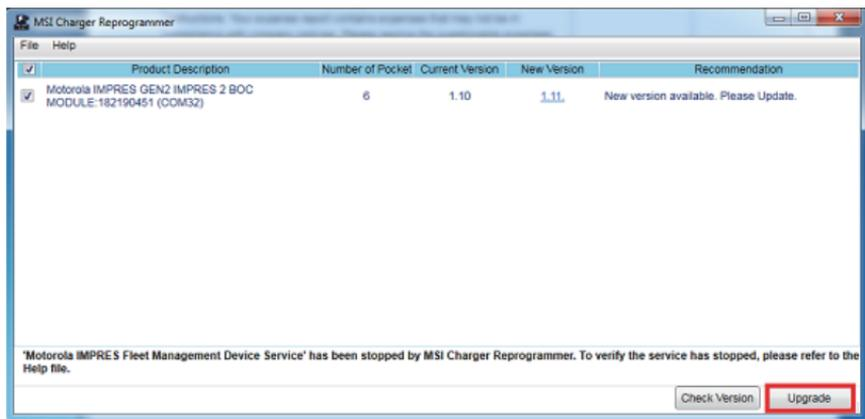

5. 업그레이드를 시작하라는 메시지가 나타나면 확인 창에서 확인을 클릭합니다. 완료될 때까지 업그레이드 진행 상태가 창에 표시됩니다.

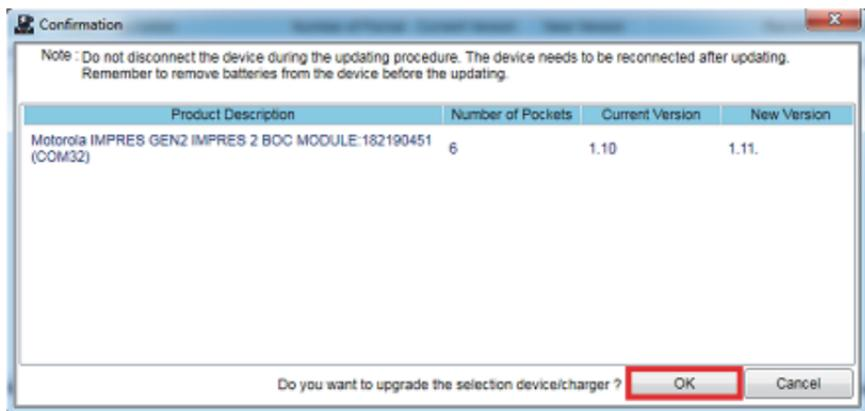

## 6. 모든 업그레이드가 완료되면 창을 닫습니다.

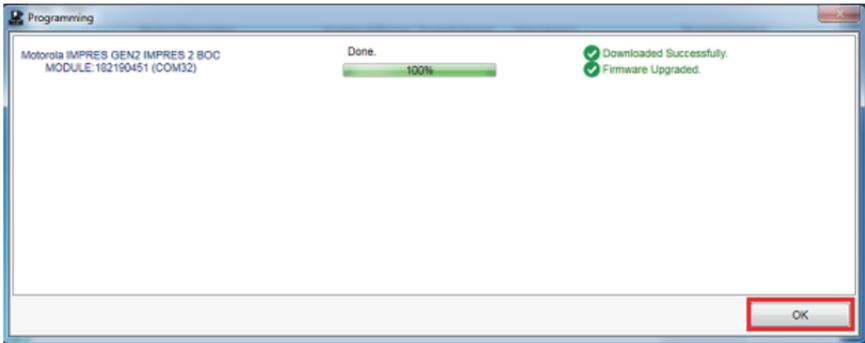

### 보정/리컨디셔닝 수동 초기화



주의: 이 아이콘이 있는 IMPRES 또는 IMPRES 2 배터리에 는 수동 보정 또는 리컨디셔닝이 적용되지 않습니다.

보정/리컨디셔닝은 보통 자동으로 수행되지만 수동 초기화가 필요한 경우가 있을 수 있습니다. 예를 들어, 충전기에서 보정이 비활성화되어 있기 때문에 충전기가 **IMPRES 2** 또는 **IMPRES** 배터리에 대하여 **황색/녹색이 교대로 깜박이는** 것을 나타내는 것일 수도 있습니다. **30분** 내에 보정이 활성화된 충전기에 이 배터리를 삽입하면 마지막 충전 상태가 재개되어 보정/리컨디셔닝이 자동으로 시작되는 것이 방지됩니다.

수동으로 보정/리컨디셔닝을 시작하려면 **IMPRES 2** 또는 **IMPRES** 배터리를 충전기로부터 **2분 30초** 이상 분리하십시오. 그런 다음, 다음 단계를 수행하십시오.

1. 배터리를 충전기 포켓에 넣습니다.
2. 2분 30초 내에 충전기 포켓에서 배터리를 꺼냅니다.
3. 5초 내에, 충전기 포켓에 배터리를 다시 넣습니다.

보정/리컨디셔닝이 즉시 시작되는데, 일반적으로 배터리 방전 상태(**황색으로 켜져 있음**)에서 시작됩니다. 완전 충전(**녹색으로 켜져 있음**) 후에만 보정/리컨디셔닝이 완료됩니다.

## 수동으로 보정/리컨디셔닝 종료

IMPRES 2 또는 IMPRES 배터리 방전(황색으로 켜짐) 중에 언제라도 다음 단계를 수행하여 보정/리컨디셔닝을 종료합니다.

1. 충전기 포켓에서 배터리를 꺼냅니다.
2. 5초 내에, 충전기 포켓에 배터리를 다시 넣습니다.

배터리 방전이 즉시 종료되고 정상 배터리 충전이 시작됩니다. LED가 충전 상태를 나타냅니다.

## 충전기 개요



그림 1: 충전기 개요

표 5: 충전기 개요 및 설명

번호	이름	설명
1-6	충전기 포켓	각 포켓에 호환 가능한 무전기 또는 독립형 배터리를 꽂을 수 있습니다.
7	통신 모듈	특정 충전기에서는 통신 모듈이 USB 액세스리도 충전합니다. • EU/영국 PS000029A03 • RK PS000029A08
8	포켓 LED 상태 표시등	충전 상태 LED(포켓 당 1개)
9	디스플레이	포켓 1번 이외의 포켓 디스플레이(선택 사항)
10	키패드/디스플레이	메뉴 키패드가 있는 포켓 1번 디스플레이
11	AC 단자 소켓	국가 또는 지역에 맞는 전원 코드를 사용합니다.

## IMPRES 2 또는 IMPRES 사용 수명 종료 LED 표시

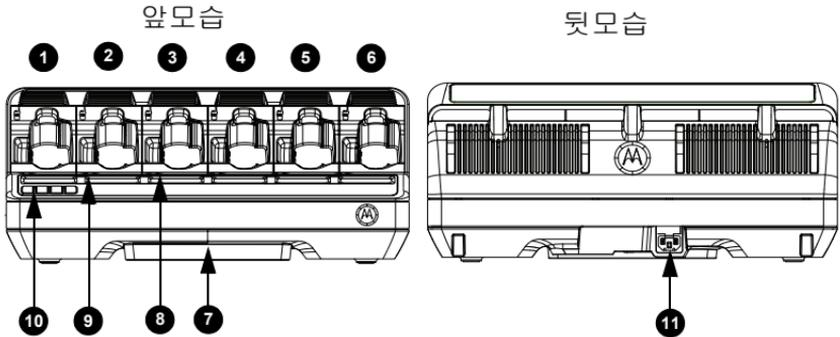
보정/리컨디셔닝이 성공적으로 완료되면, 충전기가 IMPRES 2 또는 IMPRES 배터리의 사용 수명 종료(적색/녹색이 교대로 깜박이는 것)를 나타낼 수 있습니다.

배터리가 사용되면 정상적인 소모로 인해 사용 가능한 용량이 줄어들게 됩니다. 보정/리컨디셔닝이 성공적으로 완료되면, 충전기에서 IMPRES 2 또는 IMPRES 배터리 용량과 배터리 정격 용량을 비교합니다. 용량이 매우 낮은 경우, IMPRES 2 또는 IMPRES 배터리의 사용 수명에 거의 도달한 것일 수 있습니다. IMPRES 2 또는 IMPRES 배터리를 아직 사용할 수 있으므로 일부 상황에서는 배터리를 큰 배터리 용량을 필요로 하지 않는 다른 사람에게 배포하여 남은 배터리를 사용하도록 할 수도 있습니다.

APX NEXT XN 배터리에는 소프트웨어 버전 V2.05 이상을 사용하는 IMPRES 2 충전기에서 감지할 수 있는 고온 감지 기능이 있습니다. 이 기능이 활성화되면 매우 높은 온도 환경에서 장시간 노출된 배터리가 충전 완료 시 상태 LED가 적색과 녹색으로 교대로 깜박입니다. 충전기에 다음 이 표시됩니다.

REPLACE BATTERY  
EXPOSED OVERTEMP

이 배터리를 서비스에서 분리하는 것이 권장됩니다.

## 배터리 또는 배터리가 장착된 무전기 충전

배터리는 실내 온도에서 최적의 상태로 충전됩니다. IMPRES 2 멀티 유닛 충전기는 독립형 배터리 또는 무전기에 장착된 배터리를 충전할 수 있습니다.

1. 충전기를 평면 위에 놓습니다.
2. 충전기 뒷면의 AC 단자 소켓에 전원 코드를 단단히 꽂습니다.
3. 일치하는 전원 콘센트에 전원 코드를 꽂습니다.



4. 전원이 공급되면 각 충전 상태 LED에 약 1초 동안 **녹색** 불이 깜박이고 IMPRES 2 CHARGER가 표시됩니다. 충전기 상태 LED에 불이 들어오지 않고 어떤 메시지도 표시되지 않으면 두 전원 코드 연결부를 모두 확인하십시오.
  5. 배터리를 장착한 무전기나 독립형 배터리를 포켓에 넣습니다.
- 참고:** 충전기에 무전기를 넣거나 뺄 때 무전기 본체를 잡습니다. 무전기 안테나를 잡고 당기지 마십시오.
6. 무전기 또는 독립형 배터리가 포켓에 제대로 장착되면 충전 상태가 관련 충전 상태 LED를 통해 표시됩니다. 관련 디스플레이에서 추가 정보를 제공합니다. 단일 디스플레이 충전기의 경우 포켓 1번의 충전 상태만 디스플레이에 표시됩니다.
  7. 충전 상태 표시등이 **녹색으로 계속 켜져 있으면** 배터리를 사용할 준비가 된 것입니다.
  8. 충전기 통신 모듈이 PC에서 분리되어 있는 경우에만 무전기를 켜십시오. 그렇지 않은 경우 장치 또는 무전기를 끄십시오.



그림 2: 무전기에 장착된 배터리 충전



그림 3: 독립형 배터리 충전

## USB 액세서리 충전

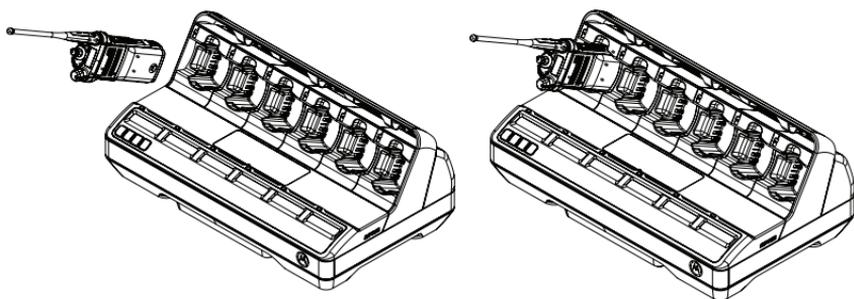
일부 IMPRES 2 멀티 유닛 충전기 통신 모듈은 USB 액세서리를 충전할 수 있는 USB Type-A 소켓을 제공합니다. USB 액세서리는 실내 온도에서 최적의 상태로 충전됩니다.

1. IMPRES 2 적응형 충전기를 평면 위에 놓습니다.
2. 충전기 뒷면의 충전기 AC 소켓에 전원 코드를 단단히 꽂습니다.
3. 일치하는 전원 콘센트에 전원 코드를 꽂습니다.
4. 전원이 공급되면 각 포켓 상태 LED에 1초 동안 녹색 불이 깜박이고 IMPRES 2 CHARGER가 표시됩니다. 상태 LED에 불이 들어오지 않거나 메시지가 표시되지 않으면 전원 코드의 연결 상태를 확인하십시오.
5. USB 액세서리에는 충전용 Micro-AB 콘센트가 하나 있을 수 있습니다. 한쪽 끝에 Type A 플러그가 있고 다른 쪽 끝에는 액세서리 호환 플러그(일반적으로 Micro-B 또는 Micro-AB)가 있는 표준 1미터 이하의 USB 케이블을 사용합니다.
6. USB 케이블 Type A 플러그가 통신 모듈의 Type A 포트를 향하도록 배치합니다. 플러그를 포트에 꽂습니다.
7. USB 케이블 Micro-B 플러그가 USB 액세서리의 Micro-AB 콘센트를 향하도록 배치합니다. 플러그를 콘센트에 꽂습니다.
8. USB 연결이 올바르게 되면 충전 상태가 USB 액세서리에 의해 표시됩니다. 자세한 내용은 USB 액세서리 사용 설명서를 참조하십시오.

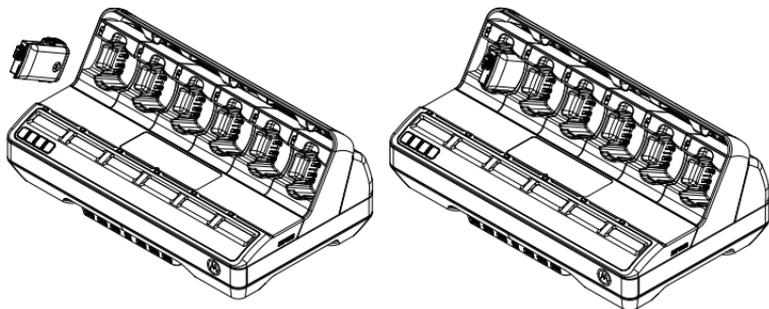
## 충전 표시

표 6: IMPRES 2 또는 IMPRES 배터리에 대한 충전 표시 - 보정 불필요

상태	포켓 디스플레이	LED 표시등
충전기에 전원 켜짐	IMPRES 2 CHARGER	약 1초 동안 녹색으로 켜짐 
배터리 감지됨	IMPRES 2 BATTERY 또는 IMPRES BATTERY	적색으로 켜짐 
고속 충전 중	RAPID CHARGE XXXXXmAh yyy%Pt1	적색으로 켜짐 
90% 이상 충전됨	TRICKLE CHARGE xxxxxmAh yyy%Pt1	녹색으로 깜박임 
95% 이상 충전됨	CHARGE COMPLETE xxxxxmAh yyy%Pt1	녹색으로 켜짐 
결함	경고: NOT CHARGEABLE REMOVE & REINSERT	적색으로 깜박임 
대기 • 배터리 고속 충전 대기 중. • 배터리가 너무 뜨겁거나, 너무 차갑거나, 전압이 낮음. • 충전기가 너무 뜨거움.	경고: HOT BATTERY WAITING TO CHARGE 또는 COLD BATTERY WAITING TO CHARGE 또는 VERY LOW BATTERY WAITING TO CHARGE 또는 HOT CHARGER WAITING TO CHARGE	황색으로 깜박임 

### 참고:

- Hot Charger (뜨거운 충전기) 메시지가 V1.05 소프트웨어에 탑재되었습니다.
- 잠재 용량 대비 정격 용량과 관련된 충전 상태 백분을 표시가 V1.11.01 소프트웨어에 탑재되었습니다.

표 7: IIMPRES 2 또는 IMPRES 배터리 보정에 대한 충전 표시 -  
보정 활성화됨

상태	포켓 디스플레이	LED 표시등
충전기에 전원 켜짐	IMPRES 2 CHARGER	약 1초 동안 녹색으로 켜짐 
배터리 감지됨	IMPRES 2 BATTERY 또는 IMPRES BATTERY	황색으로 켜짐 
배터리 방전 중	CAL DISCHARGE xxxxx@mAh yyy%Pt1	황색으로 켜짐 
고속 충전 중	CAL RAPID CHARGE xxxxx@mAh yyy%Pt1	적색으로 켜짐 
90% 이상 충전됨	CAL TRICKLE CHRG xxxxx@mAh yyy%Pt1	녹색으로 깜박임 
95% 이상 충전됨	CHARGE COMPLETE xxxxx@mAh yyy%Pt1	배터리 보정 성공: 녹색으로 켜짐 
	REPLACE BATTERY EXPOSED QUERTEMP	배터리 보정에는 성공했지만, 배터리가 사용 수명에 거의 도달한 경우(배터리 사용 가능): 빨간색/녹색으로 깜박임  
결함	경고: NOT CHARGEABLE REMOVE & REINSERT	배터리 보정에 성공했지만, 배터리가 고온에 누적 노출된 경우(플릿에서 분리하는 것이 권장됨): 적색/녹색으로 깜박임 참고: APX NEXT XN 배터리에만 적용 가능  
대기	경고: HOT BATTERY WAITING TO CAL 또는 COLD BATTERY WAITING TO CAL 또는 VERY LOW BATTERY WAITING TO CHARGE 또는 HOT CHARGER WAITING TO CAL	황색으로 깜박임 

**표 8: IMPRES 2 또는 IMPRES 배터리 보정에 대한 충전 표시 - 초기에 보정이 비활성화되었다가 활성화됨**

상태	충전기 디스플레이	LED 표시등
충전기에 전원 켜짐	IMPRES 2 CHARGER	약 1초 동안 녹색으로 켜짐 ●
배터리 감지됨	IMPRES 2 BATTERY 또는 IMPRES BATTERY	배터리 보정이 필요하지만 충전기에서 보정이 비활성화된 경우: 황색/녹색이 4초 동안 교대로 깜박임 ☀️🌱
IMPRES 배터리 보정 요청 중 • 충전기에서 보정이 비활성화되어 있음. • 배터리 충전 중	경고: ENABLE BATTERY CALIBRATION?  • OK를 눌러 보정을 활성화 • 정상 충전 무시(1분 후 메시지 없어짐)	적색으로 켜짐 ●
배터리 방전 중 • OK 선택됨	CAL DISCHARGE xxxx@mAh yy%Pt1	황색으로 켜짐 ●
고속 충전 중	CAL RAPID CHARGE xxxx@mAh yy%Pt1	적색으로 켜짐 ●
90% 이상 충전됨	CAL TRICKLE CHARGE xxxx@mAh yy%Pt1	녹색으로 깜박임 🌱
95% 이상 충전됨	CHARGE COMPLETE xxxx@mAh yy%Pt1	배터리 보정 성공: 녹색으로 켜짐 ●
	REPLACE BATTERY EXPOSED OVERTEMP	배터리 보정에는 성공했지만, 배터리가 사용 수명에 거의 도달한 경우(배터리 사용 가능): 빨간색/녹색으로 깜박임 🌱🔴  배터리 보정에 성공했지만, 배터리가 고온에 누적 노출된 경우(플릿에서 분리하는 것이 권장됨): 적색/녹색으로 깜박임 🌱🔴  참고: APX NEXT XN 배터리에만 적용 가능 🌱🔴

**표 8: IMPRES 2 또는 IMPRES 배터리 보정에 대한 충전 표시 - 초기에 보정이 비활성화되었다가 활성화됨 (계속)**

상태	충전기 디스플레이	LED 표시등
결함	경고: NOT CHARGEABLE REMOVE& REINSERT	적색으로 깜박임 
대기 • 배터리 고속 충전 대기 중. • 배터리가 너무 뜨겁거나, 너무 차갑거나, 전압이 낮음. • 충전기가 너무 뜨거움.	경고: HOT BATTERY WAITING TO CAL 또는 COLD BATTERY WAITING TO CAL 또는 VERY LOW BATTERY WAITING TO CHARGE 또는 HOT CHARGER WAITING TO CAL	황색으로 깜박임 

**표 9: IMPRES 2 또는 IMPRES 배터리에 대한 충전 표시 - 보정이 필요하지만 활성화되어 있지 않음**

상태	충전기 디스플레이	LED 표시등
충전기에 전원 켜짐	IMPRES 2 CHARGER	약 1초 동안 녹색으로 켜짐 ●
배터리 감지됨	IMPRES 2 BATTERY 또는 IMPRES BATTERY	배터리 보정이 필요하지만 충전기에서 보정이 비활성화된 경우: 황색/녹색이 4초 동안 교대로 깜박임 ☀️🌱
IMPRES 배터리 보정 요청 중 • 충전기에서 보정이 비활성화되어 있음. • 배터리 충전 중	경고: ENABLE BATTERY CALIBRATION?  • OK를 눌러 보정을 활성화. • 정상 충전 무시(1분 후 메시지가 없어짐).	적색으로 켜짐 ●
고속 충전 중 • 보정 요청 시간 초과.	RAPID CHARGE xxxx@mAh yy%Pt1	적색으로 켜짐 ●
90% 이상 충전됨	TRICKLE CHARGE xxxx@mAh yy%Pt1	녹색으로 깜박임 🌱
95% 이상 충전됨	CHARGE COMPLETE xxxx@mAh yy%Pt1	황색/녹색이 교대로 깜박임 ☀️🌱
결함	경고: NOT CHARGEABLE REMOVE& REINSERT	적색으로 깜박임 ●❗
대기 • 배터리 고속 충전 대기 중. • 배터리가 너무 뜨겁거나, 너무 차갑거나, 전압이 낮음. • 충전기가 너무 뜨거움.	경고: HOT BATTERY WAITING TO CHARGE 또는 COLD BATTERY WAITING TO CHARGE 또는 VERY LOW BATTERY WAITING TO CHARGE 또는 HOT CHARGER WAITING TO CHARGE	황색으로 깜박임 ☀️

표 10: IMPRES 2 또는 IMPRES 배터리 완전 충전에 대한 표시 - 보정이 필요하지만 활성화되어 있지 않음

상태	충전기 디스플레이	LED 표시등
충전기에 전원 켜짐	IMPRES 2 CHARGER	약 1초 동안 녹색으로 켜짐 ●
배터리 감지됨	IMPRES 2 BATTERY 또는 IMPRES BATTERY	배터리 보정이 필요, 마지막 30분 내에 완전히 충전, 그러 나 충전기에서 보정이 비활성 화되어 있음. 황색/녹색이 교대로 깜박임 
결함	경고: NOT CHARGEABLE REMOVE& REINSERT	적색으로 깜박임 
대기 • 배터리 고속 충전 대기 중. • 배터리가 너무 뜨겁거나, 너무 차갑거나, 전압이 낮음. • 충전기가 너무 뜨거움.	경고: HOT BATTERY WAITING TO CHRGE 또는 COLD BATTERY WAITING TO CHRGE 또는 VERY LOW BATTERY WAITING TO CHRGE 또는 HOT CHARGER WAITING TO CHRGE	황색으로 깜박임 



## 다른 Motorola Solutions 배터리

표 11: 다른 Motorola Solutions 배터리에 대한 충전 표시

상태	충전기 디스플레이	LED 표시등
충전기에 전원 켜짐	IMPRES 2 CHARGER	약 1초 동안 녹색으로 켜짐 
배터리 감지됨	MOTOROLA SOLUTIONS BATTERY	적색으로 켜짐 
고속 충전 중	RAPID CHARGE	적색으로 켜짐 
90% 이상 충전됨	TRICKLE CHARGE	녹색으로 깜박임 
95% 이상 충전됨	CHARGE COMPLETE	녹색으로 켜짐 
결함	경고: NOT CHARGEABLE REMOVE & REINSERT	적색으로 깜박임 
대기 • 배터리 고속 충전 대기 중. • 배터리가 너무 뜨겁거나, 너무 차갑거나, 전압이 낮음. • 충전기가 너무 뜨거움.	경고: HOT BATTERY WAITING TO CHARGE 또는 COLD BATTERY WAITING TO CHARGE 또는 VERY LOW BATTERY WAITING TO CHARGE 또는 HOT CHARGER WAITING TO CHARGE	황색으로 깜박임 

## 알 수 없는 배터리

충전기에서 일부 알 수 없는 배터리를 감지하지 못할 수 있습니다. 알 수 없는 배터리는 충전기에서 인식할 수 있는 방식으로 충전 매개 변수를 선언하지 않은 배터리입니다. 알 수 없는 배터리가 감지되면 충전기는 표 12에 요약된 대로 충전 상태를 표시합니다.

**표 12:** 알 수 없는 배터리에 대한 충전 표시

상태	충전기 디스플레이	LED 표시등
충전기에 전원 켜짐	IMPRES 2 CHARGER	약 1초 동안 녹색으로 켜짐 
배터리 감지됨	UNKNOWN BATTERY	적색으로 켜짐 
고속 충전 중	RAPID CHARGE	적색으로 켜짐 
거의 충전됨 • 배터리 용량 알 수 없음	TRICKLE CHARGE	녹색으로 깜박임 
충전됨 • 배터리 용량 알 수 없음	CHARGE COMPLETE	녹색으로 켜짐 
결함	경고: NOT CHARGEABLE REMOVE & REINSERT	적색으로 깜박임 
대기 • 배터리 고속 충전 대기 중. • 배터리가 너무 뜨겁거나, 너무 차갑거나, 전압이 낮음. • 충전기가 너무 뜨거움.	경고: HOT BATTERY WAITING TO CHARGE 또는 COLD BATTERY WAITING TO CHARGE 또는 VERY LOW BATTERY WAITING TO CHARGE 또는 HOT CHARGER WAITING TO CHARGE	황색으로 깜박임 

## IMPRES 2 또는 IMPRES 배터리 장기 보관

IMPRES 2 멀티 유닛 충전기를 사용하여 적당한 보관 위치에서 장기 보관을 위하여 인증 받은 독립형 Motorola Solutions IMPRES 2 또는 IMPRES 배터리(리튬 이온 또는 니켈)를 준비할 수 있습니다. 다른 배터리 유형에서는 결함이 발생합니다. IMPRES 2 배터리가 휴면 모드 작동 상태인 경우, 충전기는 장기 보관 충전이 완료될 때 배터리를 휴면 상태로 전환합니다.

장기 보관을 위해 IMPRES 2 또는 IMPRES 배터리만 준비합니다. 배터리를 충전기에 끼우기 전에 무전기에서 배터리를 분리합니다.

충전기에 독립형 배터리를 보관하지 마십시오. 장기 보관을 위한 준비가 완료되면 즉시 충전기에서 독립형 배터리를 분리합니다.

장기 보관 선택은 보정/리컨디셔닝을 대신합니다. 장기 보관을 위해 준비한 리튬 배터리는 항공 화물 운송 규정을 충족하지 않을 수 있습니다.

**표 13: IMPRES 2 또는 IMPRES 배터리 장기 보관 표시 - 배터리 보정 기한**

상태	충전기 디스플레이	LED 표시등
충전기에 전원 켜짐	IMPRES 2 CHARGER	약 1초 동안 녹색으로 켜짐 
배터리 감지됨	IMPRES 2 BATTERY 또는 IMPRES BATTERY	배터리 보정 필요: 황색/녹색이 4초 동안 교대로 깜박임 
배터리 방전 중	STORAGE DISCHARGE xxxx% Rated Cap	황색으로 켜짐 
고속 충전 중	STORAGE CHARGE xxx% Rated Cap	적색으로 켜짐 
장기 보관 완료	LONGTERM STORAGE xxx% Rated Cap	황색/녹색이 교대로 깜박임 

표 13: IMPRES 2 또는 IMPRES 배터리 장기 보관 표시 -  
배터리 보정 기한 (계속)

상태	충전기 디스플레이	LED 표시등
<p>결함</p> <ul style="list-style-type: none"> <li>배터리는 충전기와 적절한 전기 접촉이 없습니다.</li> <li>배터리는 IMPRES 2 또는 IMPRES 배터리가 아닙니다.</li> <li>알 수 없는 상태로 인해 배터리가 방전될 수 없습니다.</li> <li>장기 보관 목표에 도달하기 전에 충전이 완료되었습니다.</li> <li>충전 포켓이 특수 유형입니다.</li> </ul>	<p>경고:</p> <p>NOT CHARGEABLE REMOVE&amp; REINSERT 또는 WRONG BATT TYPE CANNOT LT STORE 또는 CANNOT DISCHARGE FOR LT STORAGE 또는 STORE INCOMPLETE Low Capacity:yy% 또는 RADIO POCKET CANNOT LT STORE 또는 CHARGING POCKET CANNOT LT STORE</p>	<p>적색으로 깜박임</p> 
<p>대기</p> <ul style="list-style-type: none"> <li>배터리 고속 충전 대기 중.</li> <li>배터리가 너무 뜨겁거나, 너무 차갑거나, 전압이 낮음.</li> <li>충전기가 너무 뜨거움.</li> </ul>	<p>경고:</p> <p>HOT BATTERY WAITING TO CHARGE 또는 COLD BATTERY WAITING TO CHARGE 또는 VERY LOW BATTERY WAITING TO CHARGE 또는 HOT CHARGER WAITING TO CHARGE</p>	<p>황색으로 깜박임</p> 

참고:

- 다음과 같은 메시지가 소프트웨어 버전 V1.05에서 적용되었습니다.
  - Cannot Discharge, for LT Storage
  - Store Incomplete, Low Capacity:yy%
  - Hot Charger, Waiting to Chrg
- 다음과 같은 메시지가 소프트웨어 버전 V1.11.01에서 탑재되었습니다.
  - Wrong Batt Type, Cannot LT Store
  - Radio Pocket, Cannot LT Store
  - Charging Pocket, Cannot LT Store

표 14: IMPRES 2 또는 IMPRES 배터리의 장기 보관 표시 -  
보정 배터리, 선택한 수준까지 충전해야 함

상태	충전기 디스플레이	LED 표시등
충전기에 전원 켜짐	IMPRES 2 CHARGER	약 1초 동안 녹색으로 켜짐 
배터리 감지됨	IMPRES 2 BATTERY 또는 IMPRES BATTERY	적색으로 켜짐 
고속 충전 중	STORAGE CHARGE xxx% Rated Cap	적색으로 켜짐 
장기 보관 완료	LONGTERM STORAGE xxx% Rated Cap	녹색으로 켜짐 
<b>결함</b> <ul style="list-style-type: none"> <li>배터리는 충전기와 적절한 전기 접촉이 없습니다.</li> <li>배터리는 IMPRES 2 또는 IMPRES 배터리가 아닙니다.</li> <li>알 수 없는 상태로 인해 배터리가 방전될 수 없습니다.</li> <li>장기 보관 목표에 도달하기 전에 충전이 완료되었습니다.</li> <li>충전 포켓이 특수 유형입니다.</li> </ul>	경고: NOT CHARGEABLE REMOVE & REINSERT 또는 WRONG BATT TYPE CANNOT LT STORE 또는 CANNOT DISCHARGE FOR LT STORAGE 또는 STORE INCOMPLETE Low Capacity:yy% 또는 RADIO POCKET CANNOT LT STORE 또는 CHARGING POCKET CANNOT LT STORE	적색으로 깜박임 
<b>대기</b> <ul style="list-style-type: none"> <li>배터리 고속 충전 대기 중.</li> <li>배터리가 너무 뜨겁거나, 너무 차갑거나, 전압이 낮음.</li> <li>충전기가 너무 뜨거움.</li> </ul>	경고: HOT BATTERY WAITING TO CHARGE 또는 COLD BATTERY WAITING TO CHARGE 또는 VERY LOW BATTERY WAITING TO CHARGE 또는 HOT CHARGER WAITING TO CHARGE	황색으로 깜박임 

표 15: IMPRES 2 또는 IMPRES 배터리의 장기 보관 표시 - 보정 배터리, 선택한 수준까지 방전되어야 함

상태	충전기 디스플레이	LED 표시등
충전기에 전원 켜짐	IMPRES 2 CHARGER	약 1초 동안 녹색으로 켜짐 
배터리 감지됨	IMPRES 2 BATTERY 또는 IMPRES BATTERY	황색으로 켜짐 
배터리 방전 중	STORAGE DISCHARGE xxx% Rated Cap	황색으로 켜짐 
장기 보관 완료	LONGTERM STORAGE xxx% Rated Cap	녹색으로 켜짐 
<p>결함</p> <ul style="list-style-type: none"> <li>배터리는 충전기와 적절한 전기 접촉이 없습니다.</li> <li>배터리는 IMPRES 2 또는 IMPRES 배터리가 아닙니다.</li> <li>알 수 없는 상태로 인해 배터리가 방전될 수 없습니다.</li> <li>장기 보관 목표에 도달하기 전에 충전이 완료되었습니다.</li> <li>충전 포켓이 특수 유형입니다.</li> </ul>	<p>경고:</p> <p>HOT CHARGEABLE REMOVE &amp; REINSERT 또는 WRONG BATT TYPE CANNOT LT STORE 또는 CANNOT DISCHARGE FOR LT STORAGE 또는 STORE INCOMPLETE Low Capacity:yy% 또는 RADIO POCKET CANNOT LT STORE 또는 CHARGING POCKET CANNOT LT STORE</p>	<p>적색으로 깜박임</p> 
<p>대기</p> <ul style="list-style-type: none"> <li>배터리 고속 충전 대기 중.</li> <li>배터리가 너무 뜨겁거나, 너무 차갑거나, 전압이 낮음.</li> <li>충전기가 너무 뜨거움.</li> </ul>	<p>경고:</p> <p>HOT BATTERY WAITING TO CHARGE 또는 COLD BATTERY WAITING TO CHARGE 또는 VERY LOW BATTERY WAITING TO CHARGE 또는 HOT CHARGER WAITING TO CHARGE</p>	<p>황색으로 깜박임</p> 

## 리튬 이온 배터리의 배송 준비

IMPRES 2 멀티 유닛 충전기를 사용하여 독립형 IMPRES 2, IMPRES 또는 기타 승인 받은 Motorola Solutions 리튬 이온 배터리의 항공 화물 배송을 준비할 수 있습니다. 다른 배터리 유형에서는 결함이 발생합니다. IMPRES 2 리튬 이온 배터리에 휴면 모드가 있는 경우, 충전기는 배터리를 리튬 배송 충전 완료까지 휴면 모드로 전환합니다.

배송을 위해 독립형 Motorola Solutions 리튬 이온 배터리만 준비합니다. 배터리를 충전기에 끼우기 전에 무전기에서 배터리를 분리합니다.

충전기에 독립형 배터리를 보관하지 마십시오. 리튬 충전기 배송에 대한 준비가 완료되면, 즉시 충전기에서 독립형 배터리를 분리합니다.

리튬 배터리 배송을 선택하는 것으로 보정/리컨디셔닝을 대신할 수 있습니다.

### IMPRES 2 또는 IMPRES 배터리

표 16: 배송을 위해 리튬 이온 배터리 준비 상태 표시등 - IMPRES 2 또는 IMPRES 배터리 보정 기한

상태	충전기 디스플레이	LED 표시등
충전기에 전원 켜짐	IMPRES 2 CHARGER	약 1초 동안 녹색으로 켜짐 
배터리 감지됨	IMPRES 2 BATTERY 또는 IMPRES BATTERY	배터리 보정 필요: 황색/녹색이 4초 동안 교대로 깜박임 
배터리 방전 중	SHIP LI DISCHARGE xxx% Rated Cap	황색으로 켜짐 
고속 충전 중	SHIP LI CHARGE xxx% Rated Cap	적색으로 켜짐 
리튬 배송 완료	LI READY TO SHIP xxx% Rated Cap	황색/녹색이 교대 로 깜박임 

표 16: 배송을 위해 리튬 이온 배터리 준비 상태 표시등 - IMPRES 2 또는 IMPRES 배터리 보정 기한 (계속)

상태	충전기 디스플레이	LED 표시등
<p>결함</p> <ul style="list-style-type: none"> <li>배터리는 충전기와 적절한 전기 접촉이 없습니다.</li> <li>알 수 없는 배터리 또는 니켈 배터리입니다.</li> <li>알 수 없는 상태로 인해 배터리가 방전될 수 없습니다.</li> <li>리튬 배터리 배송 목표에 도달하기 전에 충전이 완료되었습니다.</li> <li>충전 포켓이 특수 유형입니다.</li> </ul>	<p>경고:</p> <p>NOT CHARGEABLE REMOVE&amp; REINSERT 또는 WRONG BATT TYPE CANNOT SHIP LI 또는 CANNOT DISCHARGE FOR LI SHIPMENT 또는 SHIP INCOMPLETE Low Capacity:yy% 또는 RADIO POCKET CANNOT SHIP LI 또는 CHARGING POCKET CANNOT SHIP LI</p>	<p>적색으로 깜박임</p> 
<p>대기</p> <ul style="list-style-type: none"> <li>배터리 고속 충전 대기 중.</li> <li>배터리가 너무 뜨겁거나, 너무 차갑거나, 전압이 낮음.</li> <li>충전기가 너무 뜨거움.</li> </ul>	<p>경고:</p> <p>HOT BATTERY WAITING TO CHARGE 또는 COLD BATTERY WAITING TO CHARGE 또는 VERY LOW BATTERY WAITING TO CHARGE 또는 HOT CHARGER WAITING TO CHARGE</p>	<p>황색으로 깜박임</p> 

참고:

- 다음과 같은 메시지가 소프트웨어 버전 V1.05에서 적용되었습니다.
  - Ship LI Discharge, xxx% Rated Capacity
  - Ship LI Charge, xxx% Rated Capacity
  - LI Ready to Ship, xx% Rated Capacity
  - Cannot Discharge, for LI Shipment
  - Ship Incomplete, Low Capacity:yy%
- 다음과 같은 메시지가 소프트웨어 버전 V1.11.01에서 탑재되었습니다.
  - Wrong Batt Type, Cannot Ship LI
  - Radio Pocket, Cannot Ship LI
  - Charging Pocket, Cannot Ship LI



**표 17: 배송을 위해 리튬 이온 배터리 준비 상태 표시등 - IMPRES 2 또는 IMPRES 배터리 보정됨, 반드시 충전해야 함**

상태	충전기 디스플레이	LED 표시등
충전기에 전원 켜짐	IMPRES 2 CHARGER	약 1초 동안 녹색으로 켜짐 
배터리 감지됨	IMPRES 2 BATTERY 또는 IMPRES BATTERY	적색으로 켜짐 
고속 충전 중	SHIP LI CHARGE xxx% Rated Cap	적색으로 켜짐 
리튬 배송 완료	LI READY TO SHIP xxx% Rated Cap	녹색으로 켜짐 
<p>결함</p> <ul style="list-style-type: none"> <li>배터리는 충전기와 적절한 전기 접촉이 없습니다.</li> <li>알 수 없는 배터리 또는 니켈 배터리</li> <li>알 수 없는 상태로 인해 배터리가 방전될 수 없습니다.</li> <li>리튬 배터리 배송 목표에 도달하기 전에 충전이 완료되었습니다.</li> <li>충전 포켓이 특수 유형입니다.</li> </ul>	<p>경고:</p> <p>HOT CHARGEABLE REMOVE&amp; REINSERT 또는 WRONG BATT TYPE CANNOT SHIP LI 또는 CANNOT DISCHARGE FOR LI SHIPMENT 또는 SHIP INCOMPLETE Low Capacity:yy% 또는 RADIO POCKET CANNOT SHIP LI 또는 CHARGING POCKET CANNOT SHIP LI</p>	<p>적색으로 깜박임 </p>
<p>대기</p> <ul style="list-style-type: none"> <li>배터리 고속 충전 대기 중.</li> <li>배터리가 너무 뜨겁거나, 너무 차갑거나, 전압이 낮음.</li> <li>충전기가 너무 뜨거움.</li> </ul>	<p>경고:</p> <p>HOT BATTERY WAITING TO CHARGE 또는 COLD BATTERY WAITING TO CHARGE 또는 VERY LOW BATTERY WAITING TO CHARGE 또는 HOT CHARGER WAITING TO CHARGE</p>	<p>황색으로 깜박임 </p>

**표 18:** 배송을 위해 리튬 이온 배터리 준비 상태 표시등 - IMPRES 2 또는 IMPRES 배터리 보정됨, 반드시 방전해야 함

상태	충전기 디스플레이	LED 표시등
충전기에 전원 켜짐	IMPRES 2 CHARGER	약 1초 동안 녹색으로 켜짐 
배터리 감지됨	IMPRES 2 BATTERY 또는 IMPRES BATTERY	황색으로 켜짐 
배터리 방전 중	SHIP LI DISCHRG xxx% Rated Cap	황색으로 켜짐 
리튬 배송 완료	LI READY TO SHIP xxx% Rated Cap	녹색으로 켜짐 
<p>결함</p> <ul style="list-style-type: none"> <li>배터리는 충전기와 적절한 전기 접촉이 없습니다.</li> <li>알 수 없는 배터리 또는 니켈 배터리</li> <li>알 수 없는 상태로 인해 배터리가 방전될 수 없습니다.</li> <li>리튬 배터리 배송 목표에 도달하기 전에 충전이 완료되었습니다.</li> <li>충전 포켓이 특수 유형입니다.</li> </ul>	<p>경고:</p> <p>NOT CHARGEABLE REMOVE&amp; REINSERT 또는 WRONG BATT TYPE CANNOT SHIP LI 또는 CANNOT DISCHARGE FOR LI SHIPMENT 또는 SHIP INCOMPLETE Low Capacity:yy% 또는 RADIO POCKET CANNOT SHIP LI 또는 CHARGING POCKET CANNOT SHIP LI</p>	<p>적색으로 깜박임</p> 
<p>대기</p> <ul style="list-style-type: none"> <li>배터리 고속 충전 대기 중.</li> <li>배터리가 너무 뜨겁거나, 너무 차갑거나, 전압이 낮음.</li> <li>충전기가 너무 뜨거움.</li> </ul>	<p>경고:</p> <p>HOT BATTERY WAITING TO CHRGE 또는 COLD BATTERY WAITING TO CHRGE 또는 VERY LOW BATTERY WAITING TO CHRGE 또는 HOT CHARGER WAITING TO CHRGE</p>	<p>황색으로 깜박임</p> 

## 다른 Motorola Solutions 배터리

표 19: 배송을 위해 리튬 이온 배터리 준비 상태 표시등 - 다른 Motorola Solutions 배터리

상태	충전기 디스플레이	LED 표시등
충전기에 전원 켜짐	IMPRES 2 CHARGER	약 1초 동안 녹색으로 켜짐 
배터리 감지됨	MOTOROLA SOLUTIONS BATTERY	황색으로 켜짐 
배터리 방전 중	SHIP LI DISCHARGE xxx% Rated Cap	황색으로 켜짐 
고속 충전 중	SHIP LI CHARGE xxx% Rated Cap	적색으로 켜짐 
리튬 배송 완료	LI READY TO SHIP xxx% Rated Cap	녹색으로 켜짐 
<b>결함</b> <ul style="list-style-type: none"> <li>배터리는 충전기와 적절한 전기 접촉이 없습니다.</li> <li>알 수 없는 배터리 또는 니켈 배터리</li> <li>알 수 없는 상태로 인해 배터리가 방전될 수 없습니다.</li> <li>리튬 배터리 배송 목표에 도달하기 전에 충전이 완료되었습니다.</li> <li>충전 포켓이 특수 유형입니다.</li> </ul>	<b>경고:</b> NOT CHARGEABLE REMOVE& REINSERT 또는 WRONG BATT TYPE CANNOT SHIP LI 또는 CANNOT DISCHARGE FOR LI SHIPMENT 또는 SHIP INCOMPLETE Low Capacity:yy% 또는 RADIO POCKET CANNOT SHIP LI 또는 CHARGING POCKET CANNOT SHIP LI	적색으로 깜박임 
<b>대기</b> <ul style="list-style-type: none"> <li>배터리 고속 충전 대기 중.</li> <li>배터리가 너무 뜨겁거나, 너무 차갑거나, 전압이 낮음.</li> <li>충전기가 너무 뜨거움.</li> </ul>	<b>경고:</b> HOT BATTERY WAITING TO CHARGE 또는 COLD BATTERY WAITING TO CHARGE 또는 VERY LOW BATTERY WAITING TO CHARGE 또는 HOT CHARGER WAITING TO CHARGE	황색으로 깜박임 

## 충전기 설정 메뉴



충전기 설정에 들어가기 전에 모든 충전기 포켓을 비우십시오.

충전기 키패드는 포켓 1번 디스플레이 아래에 있습니다.

충전기 설정으로 들어가려면, 왼쪽 화살표 및 오른쪽 화살표 버튼을 동시에 입력 시간 선택(기본 3초)보다 길게 누르십시오.



왼쪽 화살표

오른쪽 화살표

그림 4: 설정 모드 진입을 위한 메뉴 표시 버튼

## 기본 메뉴

충전기 설정 진입에서 다음과 같은 메시지가 표시됩니다.

Press OK to entr  
SETUP MENU

다음 화면과 같이 OK를 눌러 사용 가능한 충전기 설정 메뉴를 표시합니다.



그림 5: 충전기 설정 메뉴

## 충전기 설정 메뉴 선택

각 설정 메뉴 선택 영역 내에서:

- 메뉴 선택 항목 사이를 이동하려면 오른쪽 화살표를 누릅니다.
- 메뉴 선택 항목 사이를 역순으로 이동하려면 왼쪽 화살표를 누릅니다.
- 선택한 메뉴로 들어가거나 원하는 옵션을 선택하려면 확인을 누릅니다.

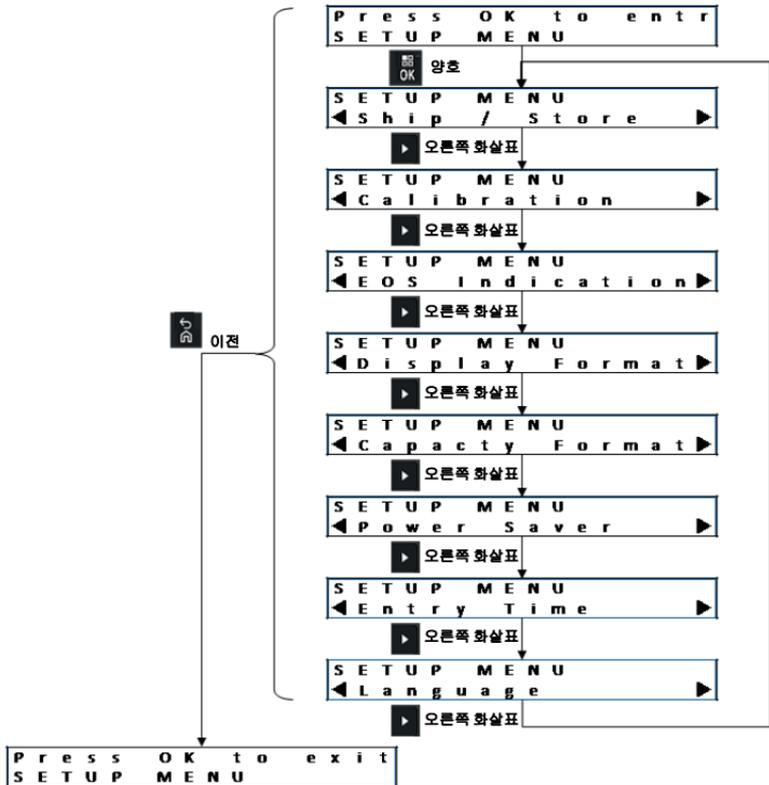
**참고:** 확인 표시는 현재 재선택된 옵션을 나타냅니다.

V1.11.01에서 탑재, 포켓 1번 디스플레이에서 다음 포켓을 표시하려면 확인을 누릅니다.

- 선택한 메뉴를 종료하려면 뒤로가기를 누른 다음 확인을 눌러 종료를 확인합니다.

10분 동안 키패드 버튼을 누르지 않으면, 충전기 설정이 종료되고 일반 메시지 디스플레이로 돌아갑니다.

비휘발성 메모리에 충전기 설정 선택 사항이 저장됩니다. 선택 사항은 충전기 전원을 껐다 켜도 영향을 받지 않습니다.

## 배송 또는 보관 메뉴

다음과 같은 4개의 배송/보관 옵션이 있습니다.

- 비활성화
- 리튬 이온 배송
- 장기 보관
- 정격 용량의 75%에서 장기 보관

리튬 이온 배송, 장기 보관, 및 장기 보관 75%의 선택 사항은 보정 설정을 대신합니다.



그림 6: 배송/보관 메뉴

## 리튬 배송

리튬 배송은 **Motorola Solutions** 리튬 이온 배터리의 충전 상태를 대량 배송을 위해 허용되는 낮은 값으로 설정하도록 하며, 이는 정격 용량의 약 **25%**입니다.

일부 **Motorola Solutions** 배터리는 리튬 배송 제한에 맞춰서 충전하기 전에 완전히 방전될 수도 있습니다. 이러한 배터리에는 이전에 보정된 적이 없거나 새 보정이 필요한 **IMPRES 2** 또는 **IMPRES** 배터리와 **IMPRES 2** 또는 **IMPRES**가 아닌 인증받은 **Motorola Solutions** 배터리가 포함됩니다.

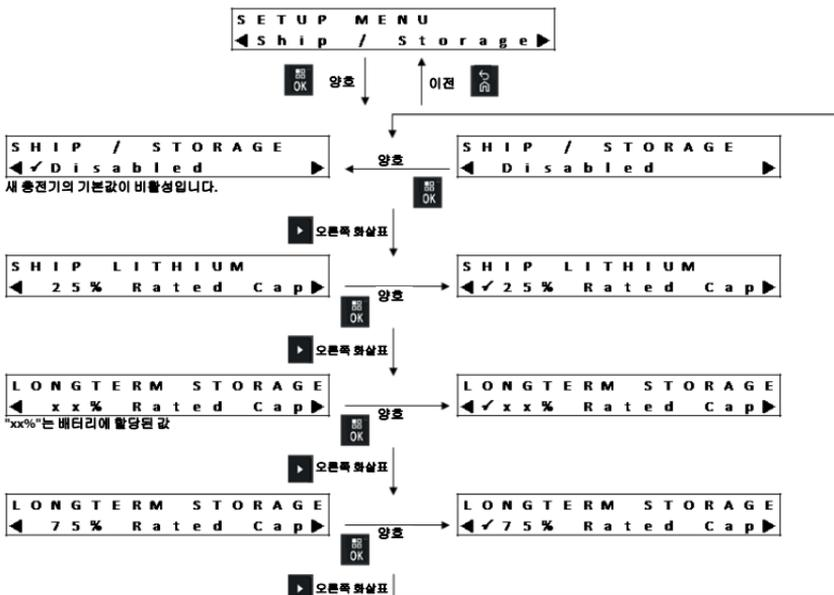
리튬 배송은 인증 받은 **Motorola Solutions** 리튬 이온 배터리(**IMPRES 2**, **IMPRES**, 또는 다른 **Motorola Solutions** 리튬 이온 배터리)에만 적용됩니다. 다른 배터리(예: 알 수 없는 배터리 또는 **Motorola Solutions** 니켈 배터리 또는 클램셀 배터리)에서는 결함이 발생할 수 있습니다.

## 장기 보관

장기 보관은 **IMPRES 2** 또는 **IMPRES** 배터리를 오랫동안 보관하기에 적합한 충전 상태로 설정합니다. 일반적으로 선호되는 충전 상태는 완전히 충전된 상태보다 훨씬 낮습니다. xx% 선택은 **IMPRES 2** 또는 **IMPRES** 배터리에서 프로그래밍된 값으로, 기본적으로 정격 용량의 **50%**로 설정됩니다. **75%** 정격 용량에서의 장기 보관은 저장되는 배터리의 높은 충전 상태를 요구하는 시나리오에서 사용 가능하며, 만약 배터리를 빨리 사용해야 하거나, 더 오랫동안 보관해야 하는 경우 등에서 완전 충전 시간을 최소화할 수 있습니다.

일부 **IMPRES 2** 또는 **IMPRES** 배터리는 장기 보관 선택 충전 전에 배터리가 완전히 방전될 수도 있습니다. 이러한 배터리에는 이전에 보정된 적이 없거나 새 보정이 필요한 **IMPRES 2** 또는 **IMPRES** 배터리가 포함됩니다.

장기 보관은 **IMPRES 2** 또는 **IMPRES** 배터리에만 적용됩니다. 다른 배터리(알 수 없는 배터리 또는 **Motorola Solutions** 비 **IMPRES** 배터리 또는 클램셀 배터리)에서는 결함이 발생합니다.

## IMPRES 2 배터리 휴면 모드

일부 IMPRES 2 배터리는 휴면 모드를 갖추고 있습니다. 휴면 모드는 다음 배터리 충전까지 시간을 연장하는 데 사용됩니다. 리튬 배송 완료 또는 장기 보관 충전에서, 충전기는 이러한 배터리를 휴면 모드로 전환합니다.

휴면 모드의 IMPRES 2 배터리를 충전기에 끼우면 휴면이 해제됩니다. 배터리가 리튬 배송을 위해 준비되는 경우, 리튬 배송 설정된 충전기에 배터리를 끼우면 배터리는 다시 휴면 모드로 전환됩니다. 배터리가 장기 보관을 위해 준비되는 경우, 장기 보관 설정된 충전기에 배터리를 끼우면 배터리는 다시 휴면 모드로 전환됩니다.

## 보정 메뉴

보정 설정 선택 사항에 따라 보정/리컨디셔닝의 방전 단계가 활성화되거나 비활성화됩니다. 방전 단계는 성공적인 보정/리컨디셔닝에 필요한 완전 충전보다 우선합니다. 이 기능은 배터리가 가능한 한 빨리 사용될 수 있는 상태에 있어야 하는 위치에 충전기를 배포할 때 유용합니다. 이러한 상황에서, 배터리가 방전될 때까지 기다리는 불편이 따를 수 있습니다.

IMPRES 2 또는 IMPRES 배터리가 보정 기한이 된 상태에서, 충전기에 삽입되었을 때 이미 방전되어 있을 경우, 충전기에서는 충전 완료를 배터리 보정을 위한 기회로 활용합니다.



그림 7: 보정 메뉴



## 사용 수명 종료 LED 표시 메뉴

IMPRES 2 또는 IMPRES 배터리가 사용 수명에 거의 도달한 경우에도, 배터리 용량은 가벼운 사용의 경우 충분한 양이 남아 있을 수 있습니다. 따라서, 사용 수명 종료 LED 표시를 비활성화하는 것이 바람직할 수 있습니다(적색/녹색이 교대로 깜박이는 것).

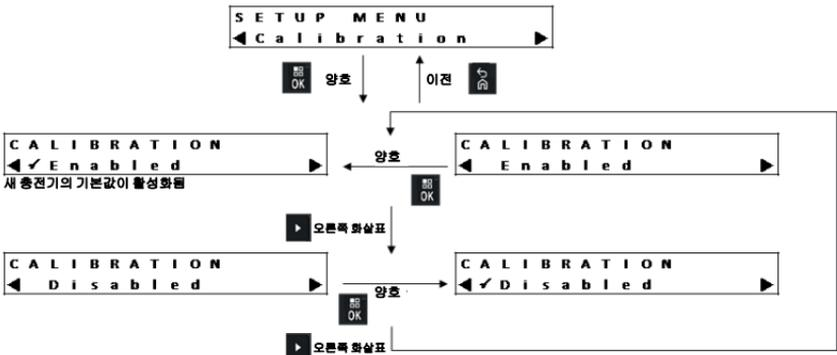
APX NEXT XN 배터리의 경우, 이 표시를 비활성화하면 고온 누적 노출 배터리의 표시도 비활성화됩니다.



그림 8: 사용 수명 종료 LED 표시 메뉴

## 디스플레이 형식 메뉴

다음과 같은 네 가지 Display Format 옵션이 있습니다.

- Normal(정방향)(충전기를 책상 위에 놓은 경우).
- Inverted(역방향)(충전기를 벽에 걸어 놓은 경우).
- Warnings Only(경고 메시지만 표시). 다른 메시지는 표시되지 않습니다. 이 옵션은 Normal(정방향) 및 Inverted(역방향)에 적용됩니다. 경고 메시지는 표 6 ~ 표 12에서 확인하실 수 있습니다.
- 디스플레이가 정상 작동 중에 꺼져 있습니다. 디스플레이가 설정 모드와 분석기 모드에서 항상 활성화되어 있습니다.

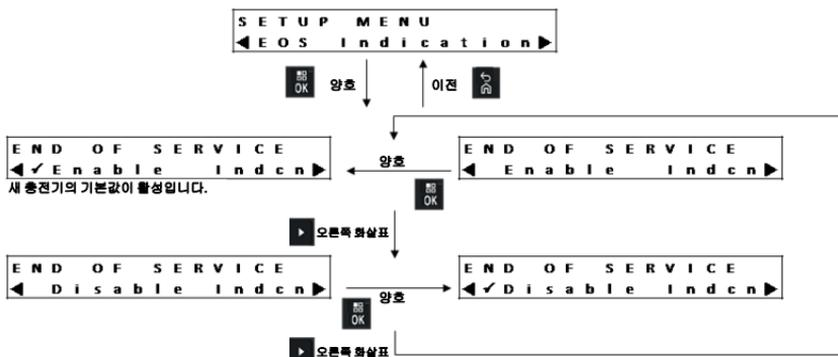

그림 9: 디스플레이 형식 메뉴

## 용량 형식 메뉴

배터리 용량은 여러가지 형식 중 하나로 표시됩니다. 배터리 용량은 백분율로 표시되는 경우, 백분율은 잠재 용량(완전 충전) 또는 정격 용량에서 참조됩니다. 일반적으로, IMPRES 무전기에서 표시되는 배터리 용량 백분율은 잠재 용량에서 참조됩니다.

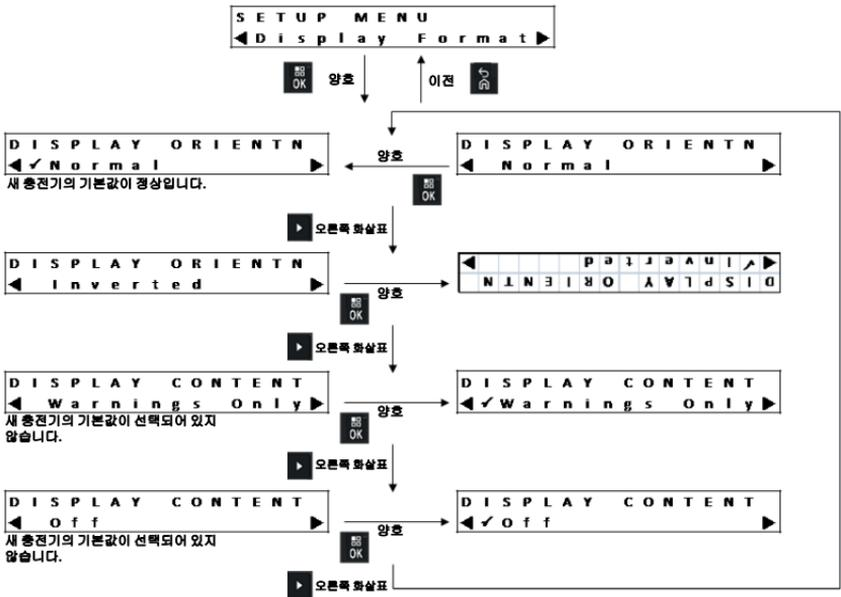

그림 10: 용량 형식 메뉴

표 20: 배터리 용량 표시 옵션

표시	설명
xxx0mAh	충전(충전 상태)을 시간당 밀리암페어로 나타냅니다.
yyy%	잠재 용량 또는 정격 용량 대비 현재 충전율을 백분율로 나타냅니다. 잠재 용량에서 참조될 때, 최대 값은 100%입니다. 정격 용량에서 참조될 때, 특별히 새 배터리의 경우, 최대 값은 100% 이상일 수도 있습니다.
%BAR	yyy%와 동일한 값을 8개의 세그먼트 막대에 나타냅니다.

## 절전 메뉴

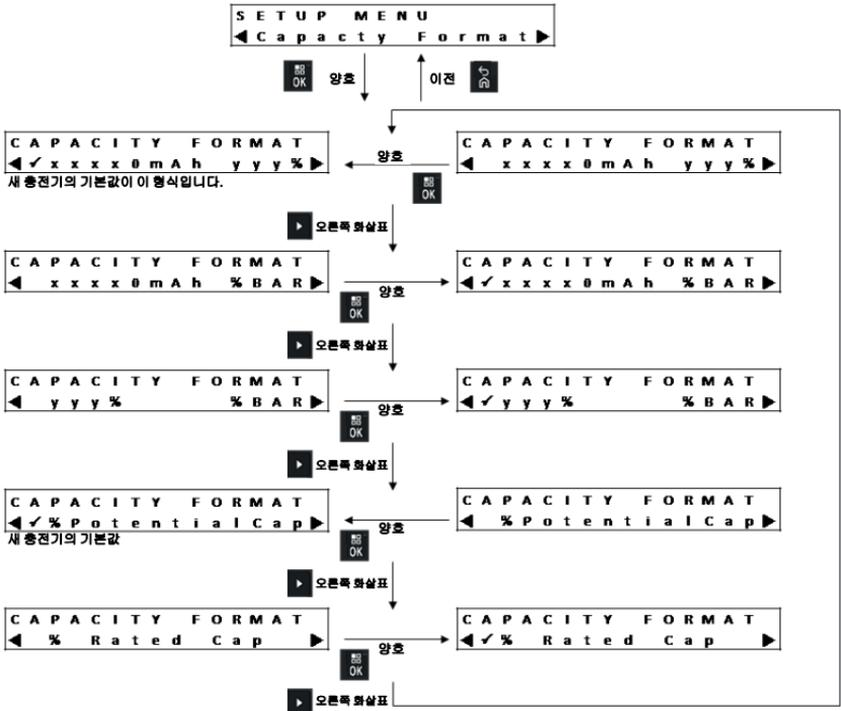
정부가 규정한 낮은 대기 전력 제한값을 만족하기 위하여 포켓 1번을 제외한 모든 포켓에서 일정 시간 동안 활동이 없으면 충전기에 절전 모드가 설정되어 해당 포켓이 꺼집니다. 이러한 활동의 예는 다음과 같습니다.

- 무전기 또는 배터리 충전.
- 배터리 보정/리컨디셔닝.
- 인증 받은 Motorola Solutions 리튬 이온 배터리 배송 준비.
- 장기 보관을 위한 IMPRES 2 또는 IMPRES 배터리 준비.
- 충전기 설정 또는 분석 모드.
- 충전기 재프로그래밍.
- IMPRES 배터리 그룹 관리 시스템과의 통신.
- 모든 깜박이는 LED 표시.



그림 11: 절전 메뉴

포켓 1번이 켜져 있지만, 휴면 모드일 수 있습니다. 다른 포켓을 켜려면, 아무 키패드 버튼이나 누릅니다. 다른 포켓이 켜질 때까지, 무전기 또는 배터리 삽입 또는 분리에 응답할 수 없습니다.

## 입력 시간 메뉴

입력 시간은 충전기 설정 모드 또는 충전기 분석기 모드로 들어가는 데 필요한 버튼을 길게 누르는 시간을 말합니다.

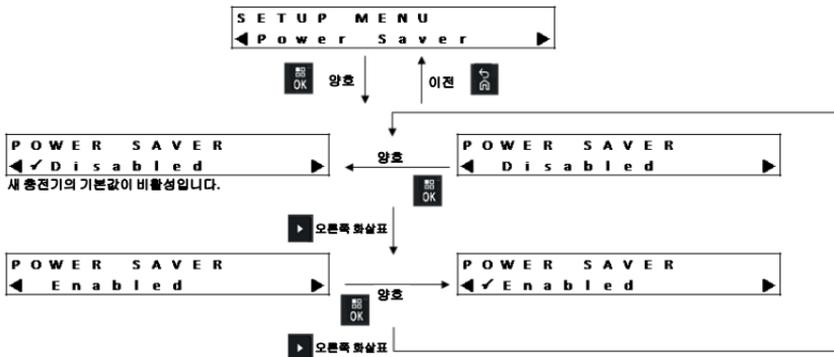

그림 12: 입력 시간 메뉴

## 언어 메뉴

현재, 충전기 디스플레이에서는 북미 지역 영어만 지원됩니다.

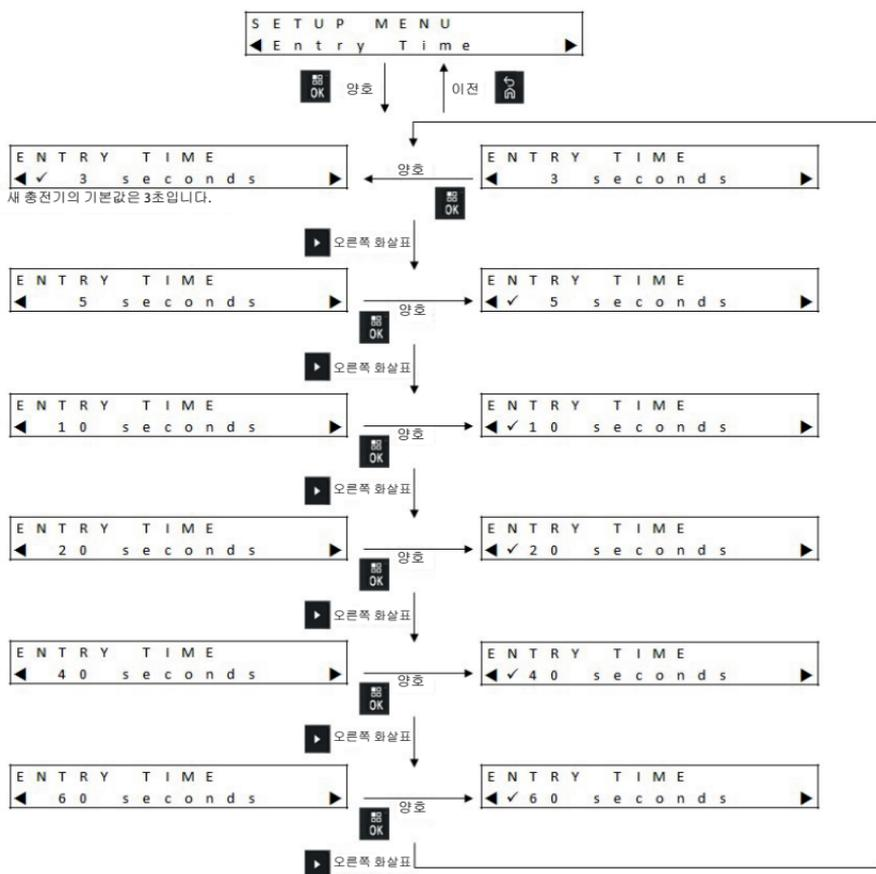

그림 13: 언어 메뉴

## 분석기 모드

충전기 키패드는 포켓 1번 디스플레이 아래에 있습니다.

분석기 모드로 들어가려면 OK 버튼을 입력 시간 선택(기본 3초)보다 길게 누릅니다.

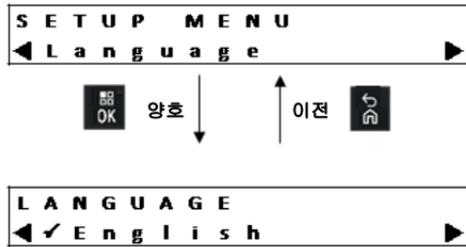
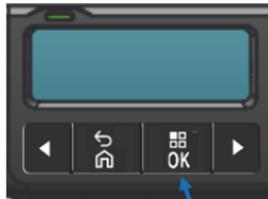

양호

그림 14: 분석기 모드 진입을 위한 메뉴 표시 버튼

분석기 모드 진입에서 다음과 같은 메시지가 표시됩니다.

Press OK to entr  
ANALYZER MODE

OK를 눌러 사용 가능한 배터리 정보를 표시하는 메시지를 표시합니다.

## 버전 V1.0 분석기 모드

소프트웨어 버전 V1.0에서 분석기 모드가 포켓 1번으로 제한됩니다. 포켓 1번 및 관련 내용에 대한 분석기 정보가 포켓 1번 디스플레이에 표시됩니다. 10분 동안 키패드 버튼을 누르지 않으면, 충전기의 분석기 모드가 종료되고 일반 메시지 디스플레이로 돌아갑니다.



그림 15: 버전 V1.0 분석기 모드 메뉴

## 버전 V1.05 분석기 모드

분석기 모드는 소프트웨어 버전 V1.05의 릴리스와 함께 더욱 향상되었습니다. 각 포켓에 디스플레이를 갖춘 충전기에서 분석기 정보는 해당 포켓에 인접한 디스플레이에 표시됩니다. 포켓 1번의 분석기 정보를 탐색하면 인접한 포켓에서 사용 가능한 분석기 정보를 다른 디스플레이에서도 탐색할 수 있습니다.

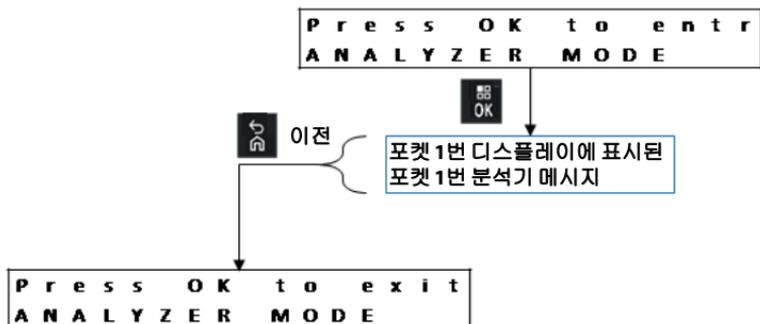

그림 16: 버전 V1.05 분석기 모드 메뉴

## 버전 V1.11.01 분석기 모드

분석기 모드는 소프트웨어 버전 V1.11.01의 릴리스와 함께 다시 더욱 향상되었습니다. 포켓 1번 전용 디스플레이를 갖춘 충전기에서, 포켓 1번 메뉴 표시를 사용하여 다른 충전기 포켓에 대한 정보를 표시합니다. 버전 V1.05에서의 개선 내용은 그대로 유지됩니다.

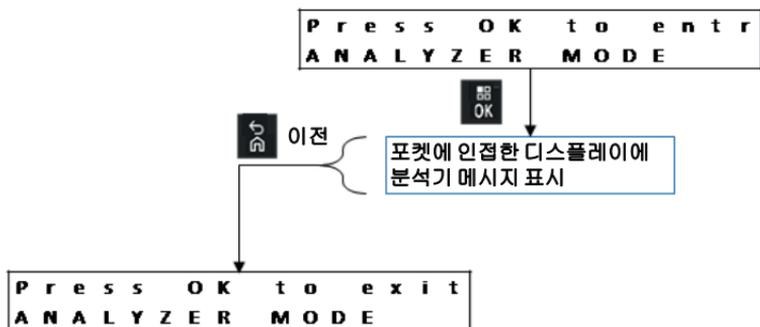

그림 17: 버전 V1.11.01 분석기 모드 메뉴

## 포켓에서 배터리 교체

배터리가 분리되어 동일한 또는 다른 배터리가 동일 포켓에 삽입된 경우, 두 번째 배터리에 표시되는 매개 변수는 첫 번째 배터리에서 표시되는 매개 변수와 동일합니다.

예를 들어 Battery IMPRES Cycles는 IMPRES 2 또는 IMPRES 배터리에서 표시됩니다. 이 배터리가 포켓에서 분리됩니다. 다른 IMPRES 2 또는 IMPRES 배터리가 동일한 포켓에 삽입됩니다. 두 번째 배터리에 대해서 표시되는 첫 번째 매개 변수가 Battery IMPRES Cycles를 표시합니다.

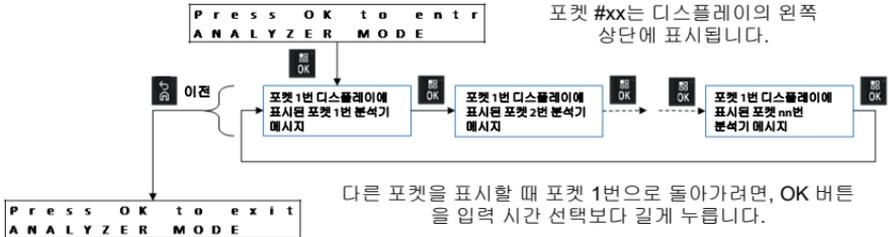
그러나 두 번째 배터리는 첫 번째 배터리에서 표시된 매개 변수를 갖지 않을 수도 있습니다. 이 경우 정보 표시 메시지가 두 번째 배터리에서 표시됩니다.



# IMPRES 2 배터리

## 포켓에 인접한 디스플레이



그림 18: 포켓에 인접한 디스플레이에 대한 IMPRES 2 배터리 분석기 모드 메뉴

## 다른 포켓을 표시하는 포켓 1번

포켓 #xx는 디스플레이의 왼쪽 상단에 표시됩니다.

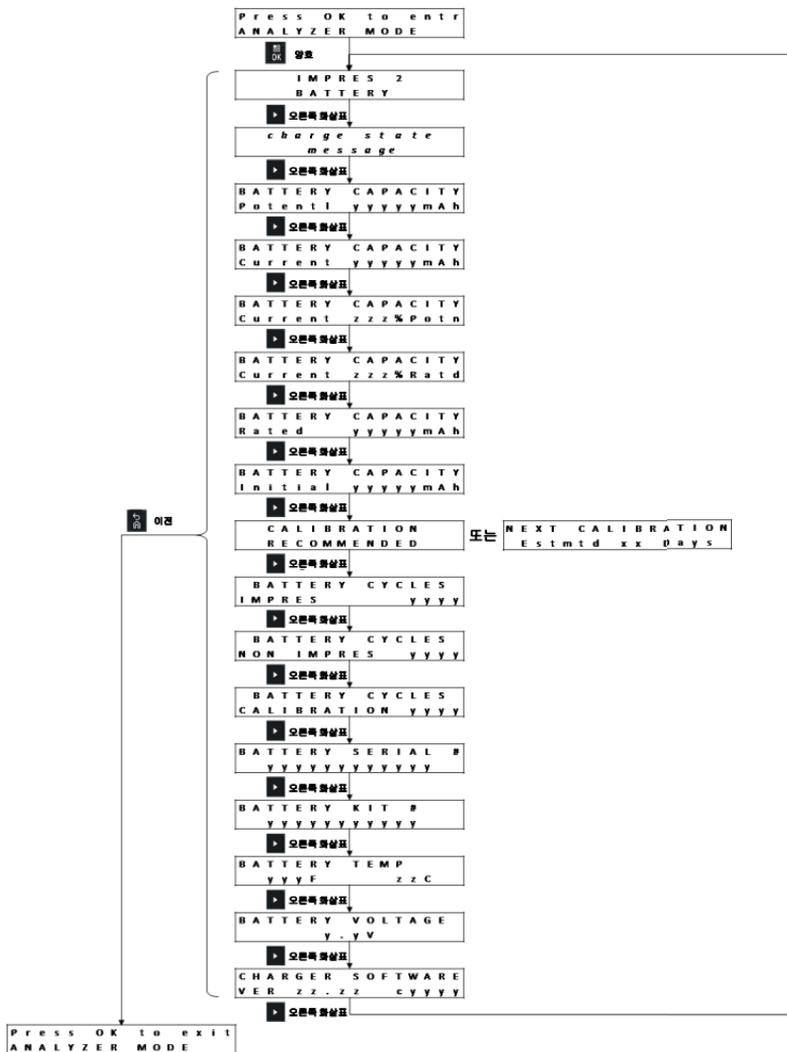

그림 19: 다른 포켓(포켓 1번 이외)에 대한 IMPRES 2 배터리 분석기 모드 메뉴

# IMPRES 배터리

## 포켓에 인접한 디스플레이

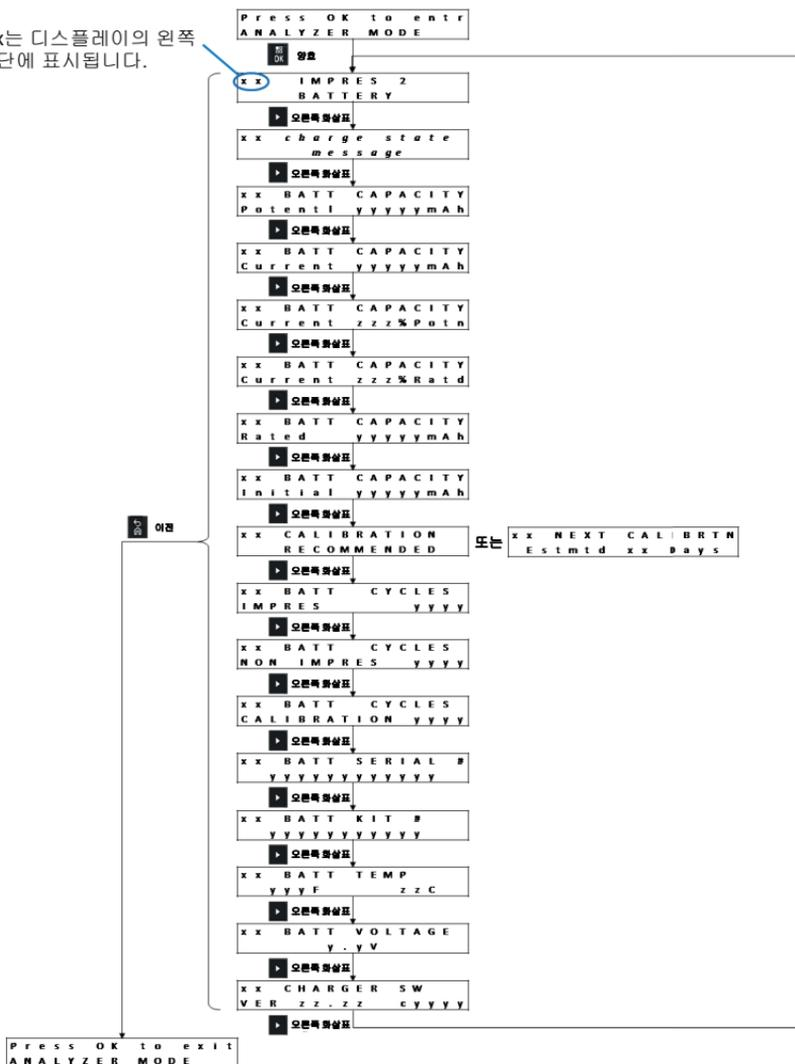

그림 20: 포켓에 인접한 디스플레이에 대한 IMPRES 배터리 분석기 모드 메뉴

## 다른 포켓을 표시하는 포켓 1번

포켓 #xx는 디스플레이의 왼쪽 상단에 표시됩니다.

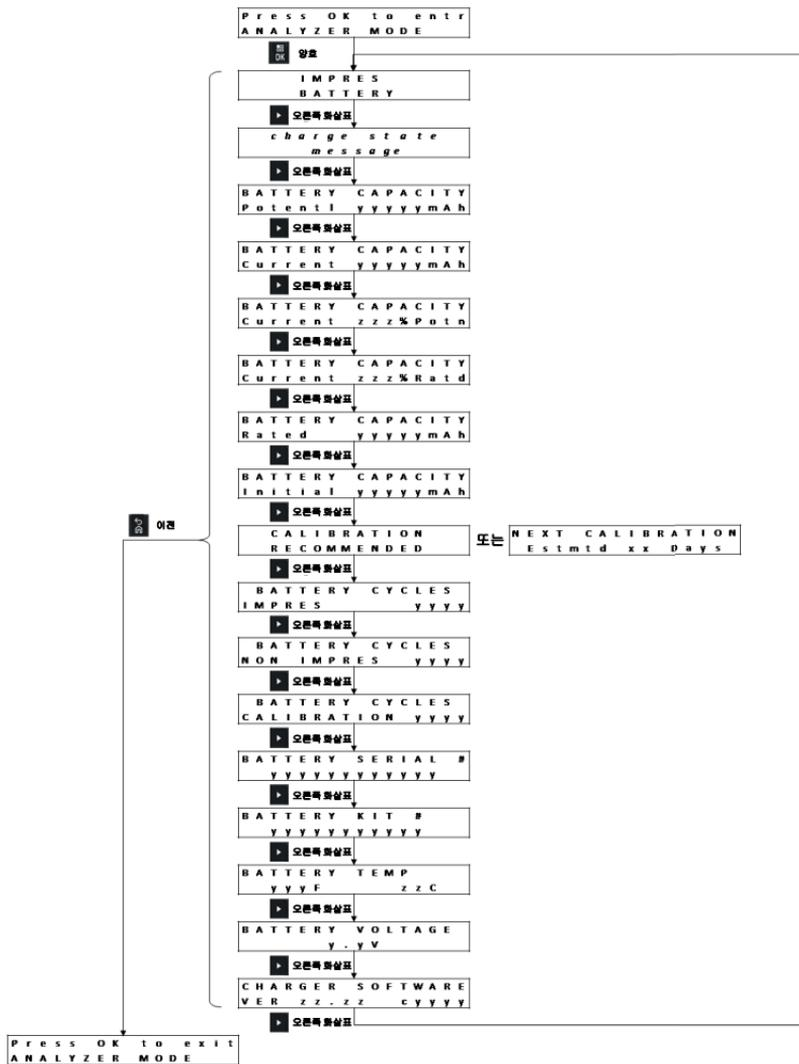

그림 21: 다른 포켓(포켓 1번 이외)에 대한 IMPRES 배터리 분석기 모드 메뉴

## 다른 Motorola Solutions 배터리

### 포켓에 인접한 디스플레이

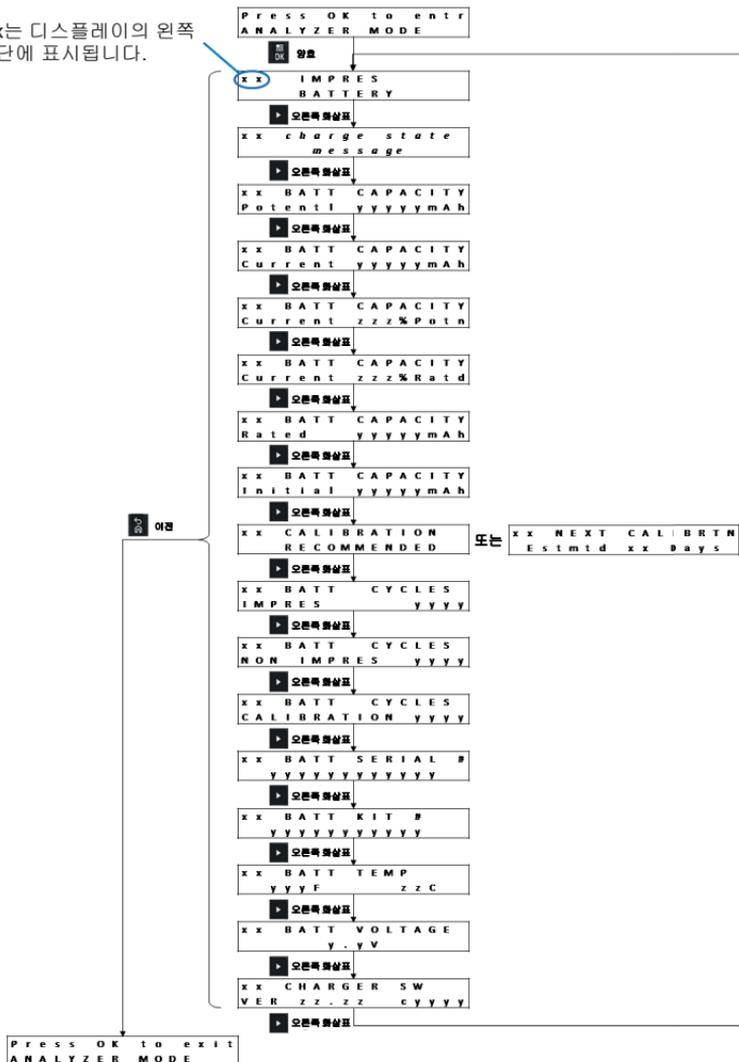

그림 22: 포켓에 인접한 디스플레이에 대한 다른 Motorola Solutions 배터리 분석기 모드 메뉴

## 다른 포켓을 표시하는 포켓 1번

포켓 #xx는 디스플레이의 왼쪽 상단에 표시됩니다.

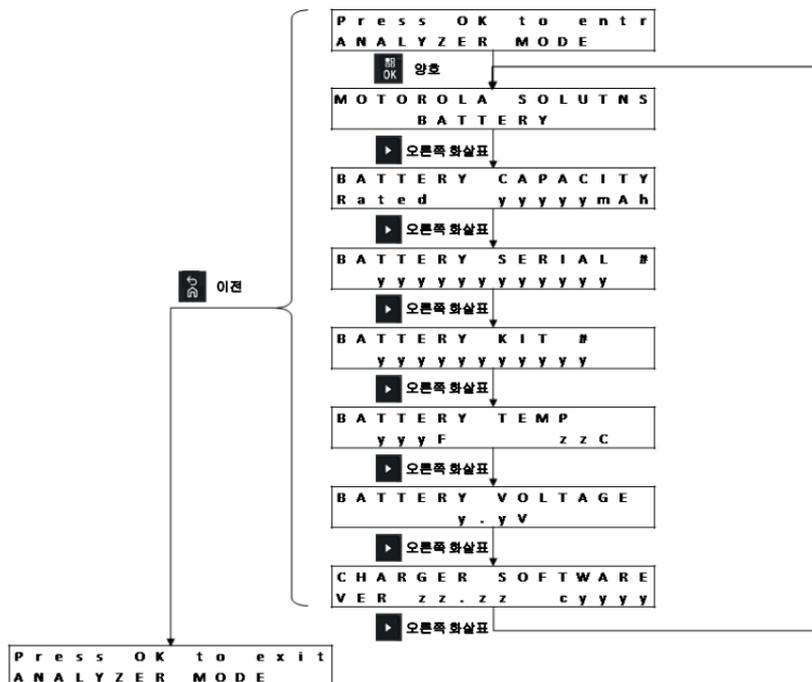

그림 23: 다른 포켓(포켓 1번 이외)에 대한 다른 Motorola Solutions 배터리 분석기 모드 메뉴

## 알 수 없는 배터리

### 포켓에 인접한 디스플레이

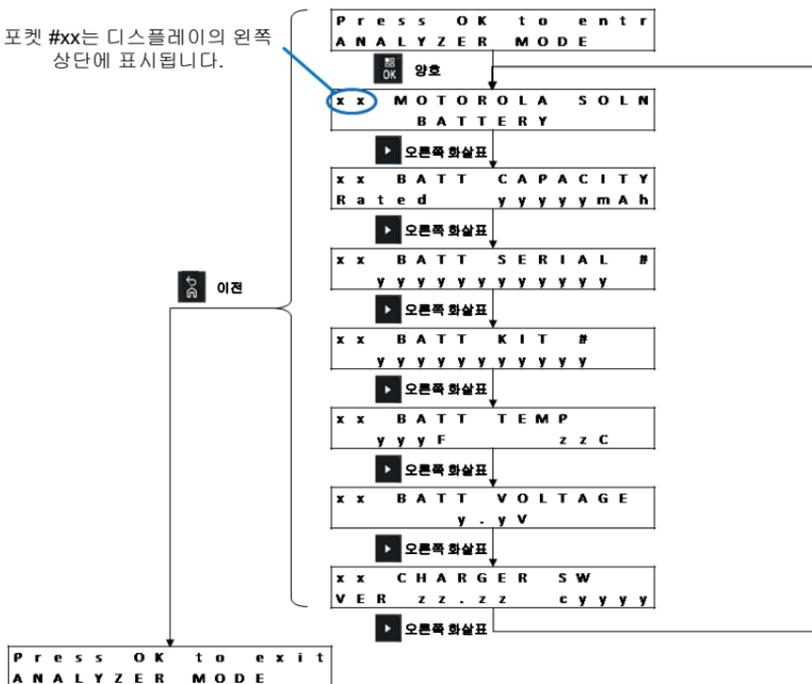

그림 24: 포켓에 인접한 디스플레이에 대한 알 수 없는 배터리 분석기 모드 메뉴

### 다른 포켓을 표시하는 포켓 1번

포켓 #xx는 디스플레이의 왼쪽 상단에 표시됩니다.

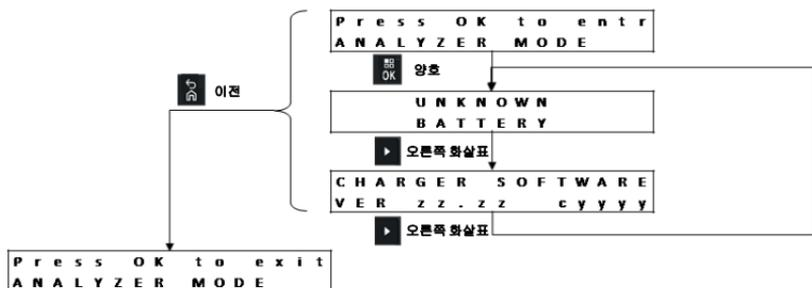

그림 25: 다른 포켓(포켓 1번 이외)에 대한 알 수 없는 배터리 분석기 모드 메뉴

## 빈 포켓

### 포켓에 인접한 디스플레이

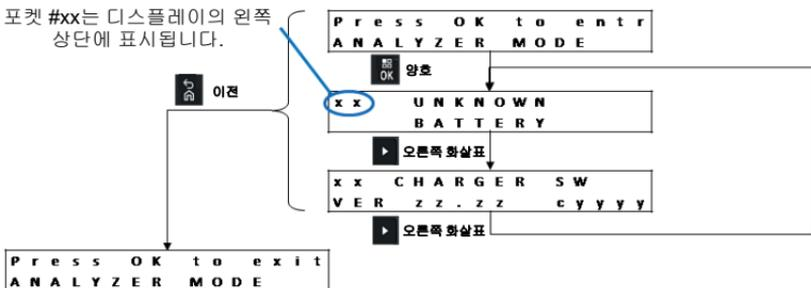

그림 26: 디스플레이에 인접한 빈 포켓에 대한 분석기 모드 메뉴

### 다른 포켓을 표시하는 포켓 1번

포켓 #xx는 디스플레이의 왼쪽  
상단에 표시됩니다.

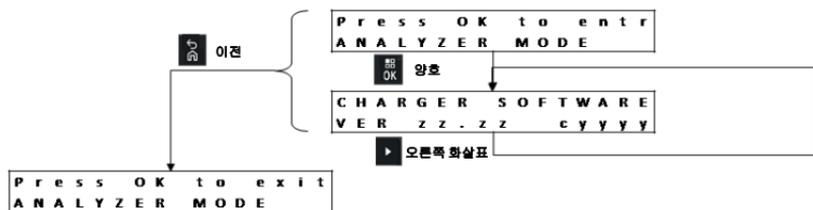

그림 27: 빈 포켓(포켓 1번 이외)에 대한 분석기 모드 메뉴

## 충전기 상태 메시지

일부 IMPRES 2 배터리는 휴면 모드를 갖추고 있습니다. 리튬 배송을 마치면 xx% 장기 보관, 또는 75% 장기 보관, 휴면 모드 장착 배터리가 휴면 상태로 전환됩니다. 분석기 모드의 청구 상태 메시지를 사용하면 휴면 상태 배터리의 충전 상태를 확인할 수 있습니다.

표 21: 리튬 배송이 활성화됨, 배터리 리튬 배송 충전 완료됨

포켓에 인접한 디스플레이	다른 포켓을 표시하는 포켓 1번
SHIP LI SLEEP xxx% Rated Cap	xx SHIP LI SLEEP xxx% Rated Cap

표 22: xx% 장기 저장 활성화됨 및 배터리 장기 보관 충전 xx% 완료됨

포켓에 인접한 디스플레이	다른 포켓을 표시하는 포켓 1번
STORAGE SLEEP xxx% Rated Cap	xx STORAGE SLEEP xxx% Rated Cap



예를 들어 충전 상태 메시지는 만약 xx% 장기 보관 활성화되고 다른 충전기에서 배터리가 75% 장기 보관 충전을 완료한 경우에는 표시되지 않습니다.

## 충전기 재프로그래밍

충전기 재프로그래밍을 하려면 표준 USB 케이블을 통해 통신 모듈이 컴퓨터에 연결되어 있어야 합니다. IMPRES 배터리 그룹 관리 시스템을 사용하여 충전기 재프로그래밍을 시작하면 충전기에서 다음 메시지가 표시됩니다.

재프로그래밍 전에 충전기에서 배터리 분리:

```
REPROGRAMMING  
REMOVE BATTERIES
```

모든 충전기 포켓 비어 있음:

```
REPROGRAMMING  
WAITING FOR DATA
```

재프로그래밍 데이터 다운로드 중:

```
REPROGRAMMING  
Progress yyy%
```

각 포켓에 디스플레이가 연결되어 있는 충전기의 경우 백분율 값이 해당 디스플레이에 연결된 포켓에 성공적으로 다운로드된 데이터 비율입니다. 한 개의 디스플레이(포켓 1번)만 있는 충전기의 경우 백분율 값은 모든 포켓에 성공적으로 다운로드된 데이터 비율입니다.

식별된 포켓에서 재프로그래밍 실패:

```
REPROGRAMMING  
POCKET#xx FAILED
```

식별된 충전기 포켓은 이전 소프트웨어를 사용하여 정상 작동을 시작합니다.

재프로그래밍 데이터 다운로드가 완료되었습니다. 충전에서 재프로그래밍 절차를 완료하였습니다.

```
IMPRES 2  
CHARGER
```

재프로그래밍 절차가 성공적으로 완료되었습니다.

```
REPROGRAMMING  
COMPLETE
```

충전기가 새로 다운로드된 소프트웨어를 사용하여 정상 작동을 시작합니다. 충전기 재프로그래밍이 완료된 후 사용자 정의 설정이 유지됩니다.

## 충전기 문제 해결

표 23: 문제 해결: 정상 충전

문제	해결 방법
포켓 LED가 충전기 전원이 켜져도 약 1초간 녹색으로 깜박이지 않습니다.	전원 코드가 충전기 및 적절한 AC 콘센트에 제대로 연결되어 있는지 확인합니다. 콘센트에 전원이 공급되는지 확인하십시오. 퓨즈를 검사하고 필요한 경우 교체합니다.
배터리 또는 무전기가 포켓에 삽입되었으나, 포켓 LED가 계속 꺼져 있고, 배터리가 인접한 디스플레이에서 식별되지 않습니다.	포켓이 포트 1번이 아니고, 절전 기능이 활성화되어 있다면, 메뉴 버튼을 누릅니다. 아래를 참조하십시오.
적색 LED가 깜박이고 디스플레이(있는 경우)에서 다음을 표시함: NOT CHARGEABLE REMOVE & REINSERT Motorola Solutions의 배터리가 포켓에 삽입되어 있으나, 디스플레이에서 다음을 표시함(있는 경우): UNKNOWN BATTERY	 <p>포켓에서 배터리 또는 무전기를 분리합니다. 오염, 손상, 또는 물리적인 손상이 있는지 배터리와 충전기 포켓의 전기 접촉단자를 확인합니다. 배터리가 인증 받은 Motorola Solutions 배터리인지 확인합니다. 다른 배터리는 충전되지 않을 수 있습니다. 마른 천을 사용하여 배터리 전기 접촉단자를 닦으십시오. 충전기에서 전원을 분리하고, 마른 천을 사용하여 포켓의 전기 접촉단자를 닦으십시오. 배터리를 교체하십시오. 결함이 더 이상 발생하지 않으면 결함이 있는 배터리를 사용하지 마십시오. 교체 배터리에도 결함이 계속되면 충전기를 사용하지 마십시오.</p>
보정이 끝나면 적색/녹색 LED가 교대로 깜박입니다.	 <p>IMPRES 2 또는 IMPRES 배터리의 사용 수명에 거의 도달했을 수도 있습니다. 배터리를 사용할 수 있으나 사용 가능한 용량이 근무 조 근무 시간 연장 시에는 충분하지 않을 수 있습니다. APX NEXT XN 배터리에만 적용 가능: 배터리가 10분 이상 고온에 노출되었습니다. 배터리를 서비스에서 분리하는 것이 권장됩니다.</p>
충전기에 배터리를 삽입하면 약 4초 동안 황색/녹색 LED가 교대로 깜박입니다.	 <p>IMPRES 2 또는 IMPRES 배터리의 보정/리컨디셔닝이 필요합니다. 다음 기회에 보정이 활성화된 IMPRES 2 충전기에 배터리를 삽입하여 충전기에서 보정을 완료하도록 합니다(녹색으로 켜짐).</p>

**표 23: 문제 해결: 정상 충전 (계속)**

문제	해결 방법
분석기 모드에서 포켓 1번이 다른 포켓을 표시할 수 있습니다.	충전기가 하나 이상의 다른 포켓에서 디스플레이를 감지할 수 없습니다.

**표 24: 문제 해결: 장기 보관 충전**

문제	해결 방법
적색 LED가 깜박이고 디스플레이(있는 경우)에서 다음을 표시함: WRONG BATT TYPE CANNOT LT STORE 또는 CANNOT DISCHARGE CANNOT LT STORE	<p>포켓에서 배터리를 분리합니다. 배터리가 무전기에 장착되어 있지 않은지 확인합니다.</p> <p>배터리가 <b>IMPRES 2</b> 또는 <b>IMPRES</b> 배터리인지 확인합니다. 다른 배터리에서는 결함이 발생합니다.</p> <p>마른 천을 사용하여 <b>IMPRES 2</b> 또는 <b>IMPRES</b> 배터리의 전기 접촉단자를 닦습니다.</p> <p>충전기에서 전원을 분리하고, 마른 천을 사용하여 포켓의 전기 접촉단자를 닦으십시오.</p> <p>다른 <b>IMPRES 2</b> 또는 <b>IMPRES</b> 배터리로 교체해 보십시오. 결함이 더 이상 발생하지 않으면, 결함이 있는 <b>IMPRES 2</b> 또는 <b>IMPRES</b> 배터리를 사용하지 마십시오.</p> <p>교체된 <b>IMPRES 2</b> 또는 <b>IMPRES</b> 배터리에도 결함이 계속되면 충전기를 사용하지 마십시오.</p>
적색 LED가 깜박이고 디스플레이(있는 경우)에서 다음을 표시함: STORE INCOMPLETE Low Capacity:yy%	<b>IMPRES 2</b> 또는 <b>IMPRES</b> 배터리의 잠재 용량이 장기 보관 선택보다 적을 수도 있습니다. 배터리 사용 수명에 거의 도달한 것일 수도 있습니다.
적색 LED가 깜박이고 디스플레이(있는 경우)에서 다음을 표시함: RADIO POCKET CANNOT LT STORE 또는 CHARGING POCKET CANNOT LT STORE	<p>충전기 포켓은 배터리 충전을 위한 표준 포켓이 아닙니다(충전기와 배터리 사이의 전기 접촉단자를 통해서).</p> <ul style="list-style-type: none"> <li>무전기 포켓은 배터리가 무전기에 장착되어 있는 특수 포켓으로, 배터리에 외부 접촉단자가 없으며, 배터리는 무전기의 전기 접촉단자를 통해서 충전됩니다.</li> <li>충전 포켓은 <b>USB</b> 충전 포트와 같이 특수한 목적을 위해 충전 에너지를 사용하는 포켓입니다.</li> </ul> <p>배터리를 표준 포켓으로 옮기거나 무전기 포켓 또는 충전 포켓을 표준 포켓으로 교체합니다.</p>

표 25: 문제 해결: 리튬 배송 충전

문제	해결 방법
<p>적색 LED가 깜박이고 디스플레이(있는 경우)에서 다음을 표시함: WRONG BATT TYPE CANNOT SHIP LI</p> 	<p>포켓에서 배터리를 분리합니다. 배터리가 무전기에 장착되어 있지 않은지 확인합니다.</p> <p>배터리가 IMPRES 2, IMPRES 또는 인증 받은 다른 Motorola Solutions의 리튬 이온 배터리인지 확인합니다. 다른 배터리에서는 결함이 발생합니다.</p> <p>IMPRES 2, IMPRES 또는 다른 인증 받은 Motorola Solutions 리튬 이온 배터리의 전기 접촉단자를 마른 천을 사용하여 닦으십시오. 충전기에서 전원을 분리하고, 마른 천을 사용하여 포켓의 전기 접촉단자를 닦으십시오.</p> <p>다른 IMPRES 2, IMPRES 또는 인증 받은 Motorola Solutions의 리튬 이온 배터리로 교체하십시오. 결함이 더 이상 발생하지 않으면 결함이 있는 IMPRES 2, IMPRES 또는 인증 받은 Motorola Solutions의 리튬 이온 배터리를 사용하지 마십시오.</p> <p>교체한 IMPRES 2, IMPRES 또는 인증 받은 Motorola Solutions의 리튬 이온 배터리에서 결함이 계속되면 충전기를 사용하지 마십시오.</p>
<p>적색 LED가 깜박이고 디스플레이(있는 경우)에서 다음을 표시함: SHIP INCOMPLETE Low Capacity:yy%</p> 	<p>인증 받은 Motorola Solutions 리튬 이온 배터리의 잠재 용량은 배송 리튬 제한보다 적을 수 있습니다. 배터리 사용 수명에 거의 도달한 것일 수도 있습니다.</p>
<p>적색 LED가 깜박이고 디스플레이(있는 경우)에서 다음을 표시함: RADIO POCKET CANNOT LT STORE 또는 CHARGING POCKET CANNOT SHIP LI</p> 	<p>충전기 포켓은 배터리 충전을 위한 표준 포켓이 아닙니다(충전기와 배터리 사이의 전기 접촉단자를 통해서).</p> <ul style="list-style-type: none"> <li>무전기 포켓은 배터리가 무전기에 장착되어 있는 특수 포켓으로, 배터리에 외부 접촉단자가 없으며, 배터리는 무전기의 전기 접촉단자를 통해서 충전됩니다.</li> <li>충전 포켓은 USB 충전 포트와 같이 특수한 목적을 위해 충전 에너지를 사용하는 포켓입니다.</li> </ul> <p>배터리를 표준 포켓으로 옮기거나 무전기 포켓 또는 충전 포켓을 표준 포켓으로 교체합니다.</p>

## IMPRES 배터리 그룹 관리 시스템

IMPRES 배터리 그룹 관리 소프트웨어는 IMPRES 충전기에 삽입되어 있는 IMPRES 또는 IMPRES 2 배터리에서 중요 데이터를 자동으로 수집합니다. 중요 데이터에는 배터리 연식, 용량, 충전 및 보정/리컨디셔닝 기록, 제조 날짜, 서비스 받은 날짜 등이 포함됩니다. IMPRES 배터리 그룹 관리 소프트웨어는 배터리 데이터를 분석하고, 배터리 상태에 대해 통신하고, 배터리 교체 시기를 추천해 줍니다. 따라서 사용량이 적은 사용자에게 배터리를 재배포할지 여부, 새 교체용 배터리를 구입할 시기 또는 누락된 배터리 추적 시기를 빠르고 효율적으로 판단할 수 있습니다.

IMPRES 배터리 그룹 관리는 다음과 같이 배터리 관련 중요 정보를 제공합니다.

- 배터리 용량이 허용 가능한 수준 미만인 경우 알림.
- 사용자가 근무 시간 내에 필요한 충분한 용량을 확보하도록 지원.
- 용량이 낮은 배터리를 식별하여 사용되지 않도록 함.
- 예기치 못한 가동 중단 시간과 작업 중단 해소.
- 조기 배터리 폐기 비용 방지.
- 최적의 충전기 배포 및 사용 보장.

IMPRES 배터리 그룹 관리 애플리케이션 소프트웨어는 단일 사이트에서 다중 사이트 네트워크 시스템으로 Figure 28에서 보는 바와 같이 확장 가능합니다. IMPRES 배터리 그룹 관리 시스템은 다음을 지원합니다

- 시스템 관리자 서버 한 대
- 원격 클라이언트 19대
- 클라이언트당 IMPRES 충전기 또는 IMPRES 배터리 판독기 25개
- 동일한 위치 또는 지리적으로 분산된 영역의 IMPRES 배터리 25,000개(전체 시스템의 총 배터리 수는 25,000개를 초과할 수 없음).

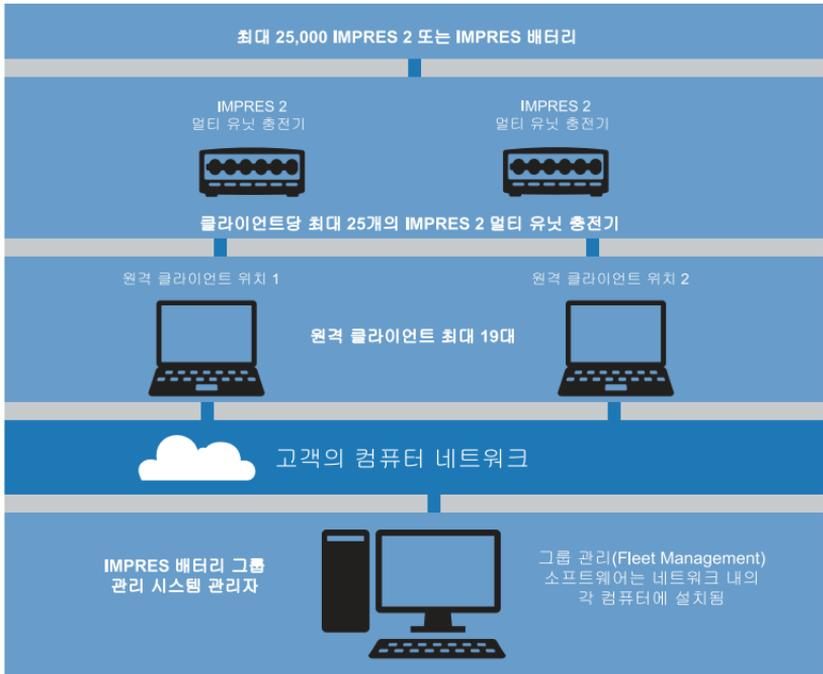

**그림 28:** 네트워크 충전기를 통한 IMPRES 배터리 그룹 관리  
 IMPRES 배터리 그룹 관리는 다음과 같은 세 가지 주요 구성 요소로 구성됩니다.

- 응용 프로그램 소프트웨어
- 소프트웨어 라이선스 키
- IMPRES 2 충전기, IMPRES 2 통신 모듈, IMPRES 충전기 인터페이스 유닛(CIU), 또는 IMPRES 배터리 데이터 판독기를 원격 클라이언트를 호스팅하는 컴퓨터에 연결해주는 USB 케이블

조직과 가장 관련성이 큰 정보를 보려면 기존 보고서에서 새로운 항목 사용자 정의를 참조하십시오. 데이터는 데이터베이스에 저장되며 Excel™ 파일로 내보내거나 인쇄할 수 있습니다. IMPRES 배터리 그룹 관리 소프트웨어는 다양한 데이터를 기록하고 구성할 수 있으므로 다음과 같은 작업이 가능합니다.

- 전체 배터리 그룹의 상태 스냅샷 확인
- 배터리가 성능 기준을 충족하는지 여부 평가
- 배터리 사용 수명 종료 시기 확인
- 새 배터리 구입 시기를 정확히 예측
- 분실 배터리 보고서 획득
- 충전기 활용 최적화
- 시스템의 모든 장치 모니터링

Serial Number	Alias	Group	Radio Family	ID Number	Chemistry	ISE	Rated Capacity	Potential Capacity	Date of Prod. Use
100000185479	Sam	Building 1	VTX 5000/3500/2000	HW000118	NaCl	No	1525	1576	01/1/2009
100000181480	Math	Security	APR	NW170732A	NaISe	No	2100	1480	02/18/2008
100000184848	Michael	Security	APR	NW170732A	NaISe	Yes	1600	1600	2/4/2007
100000185511	Phil	Administration	HTCG/PRO Series	HW000248	NaCl	No	1555	1240	1/4/2009
100000171122	Pat	Building 1	VTX 5000/3500/2000	NW170478	NaISe	Yes	1700	1600	01/04/2008
100000174858	James	Building 1	VTX 2000, 3750/4750, 6500	NW170564	Li-Ion	No	2000	2000	2/24/2008
100000184801	Active	hour	Subar	HW000108	NaCl	No	2000	1600	5/5/2009
100000184878	Jack	Building 2	VTX 2000, 3750/4750, 6500	NW170564	Li-Ion	No	2000	1640	01/11/2009
100000180111	Gene	Building 2	VTX 2000, 3750/4750, 6500	NW170564	Li-Ion	No	2000	2040	02/21/2009
1000001804120	Bob	hour	Subar	HW000148	NaCl	Yes	2000	1600	02/3/2008
100000180211	Carol	Administration	HTCG/PRO Series	HW000242	NaISe	Yes	1600	1392	01/12/2009
100000184807	Pat	Building 1	VTX 5000/3500/2000	NW170456	NaISe	Yes	1700	1607	02/21/2008
100000181260	Don	Building 1	VTX 8500/3500/3500	HW000118	NaCl	No	1525	1580	0/3/2008
100000180403	Bill	Security	APR	NW170732A	Li-Ion	Yes	4100	2941	07/21/2006
100000180402	Frank	Security	APR	NW170732A	NaISe	No	2100	1495	02/13/2008
100000181717	Mark	Building 2	VTX 5000/3500/2000	NW170456	Li-Ion	Yes	3900	2004	01/18/2009
100000184238	Eric	Maintenance	MTCOTRBO	PRM00723A	Li-Ion	No	1150	1150	2/28/2008
100000184376	John	Administration	HTCG/PRO Series	HW000248	NaCl	No	1600	1100	07/19/2008
100000180401	Phil	Building 1	APR	NW170732A	NaISe	No	2100	1491	0/2/2008
100000180402	Tom	hour	APR	NW170732A	Li-Ion	Yes	4100	2942	07/20/2006
100000180407	Lee	Maintenance	HTCG/PRO Series	HW000248	NaCl	No	1500	1100	1/10/2009
100000184211	Don	Building 2	VTX 5000/3500/2000	PRM0093A	NaISe	No	2000	2070	06/08/2007
100000184219	Paul	Administration	MTCOTRBO	PRM00665A	Li-Ion	Yes	1400	966	0/1/2008
1000001704213	Frank	Building 1	APR	NW170732A	NaISe	Yes	2000	1380	07/02/2008
100000170902	Tim	Security	MTCOTRBO	PRM00665A	Li-Ion	Yes	1400	966	0/12/2007
1000001705017	John	Maintenance	APR	NW170732A	NaISe	No	2100	1449	1/1/2008
1000001704216	Scott	Building 2	HTCG/PRO Series	HW000242	NaISe	No	1800	1242	00/12/2009
1000001704218	John	Security	VTX 8500/3500/3500	NW170456	Li-Ion	No	4100	2946	0/6/2008
1000001704219	Bob	Administration	APR	NW170732A	NaISe	No	2100	1449	0/11/2008
1000001704761	Mark	Building 1	MTCOTRBO	PRM00665A	Li-Ion	No	1500	1033	00/11/2007

그림 29: 활성 배터리 보고서

한도인



그림 30: 무전기 제품군에서 사용 중인 배터리



Serial Number	Alias	Group	Make	Model	Alt. Number	Chemistry	Amps	Total Capacity	Potential Capacity	Date of Next Use	Recommendations	Days since Last Used	Age
00000101919	UPS	Building 1	APC	9300 (9300-0000)	99990110	Ni-Cd	No	1420	1410	6/1/2009	Replace or Calibrate Battery	160	10
00000101912	UPS	Building 1	APC	9300 (9300-0000)	99979400	Ni-Cd	Yes	1750	1700	6/16/2009	No Recommendations	160	9
00000104008	UPS	Building 1	APC	2500 (2500-0000)	99979300	Li-Ion	No	2000	2000	1/24/2009	No Recommendations	160	8
00000104007	UPS	Building 1	APC	2500 (2500-0000)	99979300	Li-Ion	Yes	2700	2670	1/23/2009	No Recommendations	160	7.5
00000104009	UPS	Building 1	APC	2500 (2500-0000)	99980100	Ni-Cd	No	1600	1580	6/1/2009	No Recommendations	160	7.5
00000101900	UPS	Security	APC	9300 (9300-0000)	99979300	Ni-Cd	No	1750	1600	1/21/2009	No Recommendations	160	8
00000104004	UPS	Administration	APC	9300 (9300-0000)	99980100	Li-Ion	No	2000	1920	1/23/2009	No Recommendations	160	7.5
00000101901	UPS	Building 1	APC	2500 (2500-0000)	99979300	Li-Ion	No	2000	1980	7/1/2009	No Recommendations	160	8
00000101903	UPS	Administration	APC	2500 (2500-0000)	99979300	Li-Ion	No	2000	1980	7/1/2009	No Recommendations	160	8

그림 31: 위치별 분실 배터리

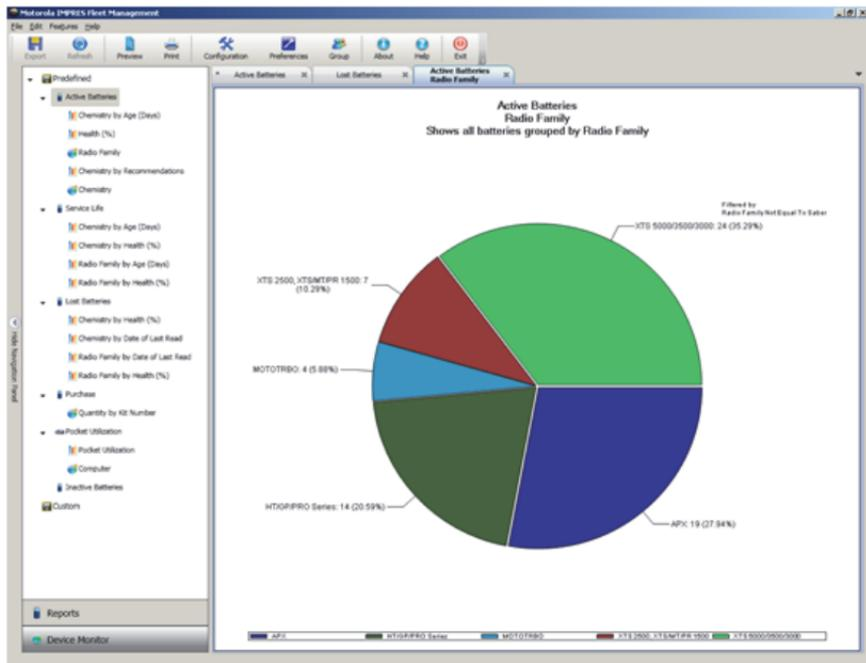
원문



그림 32: 충전기 포켓 활용 현황

## 멀티 유닛 충전기 벽면 부착

벽 부착용 받침대(부품 번호: 0705559L01)를 멀티 유닛 충전기에 사용할 수 있습니다. 이 제품을 주문하려면 현지 대리점에 문의하십시오. 설치 방법은 아래에 제시되어 있습니다.

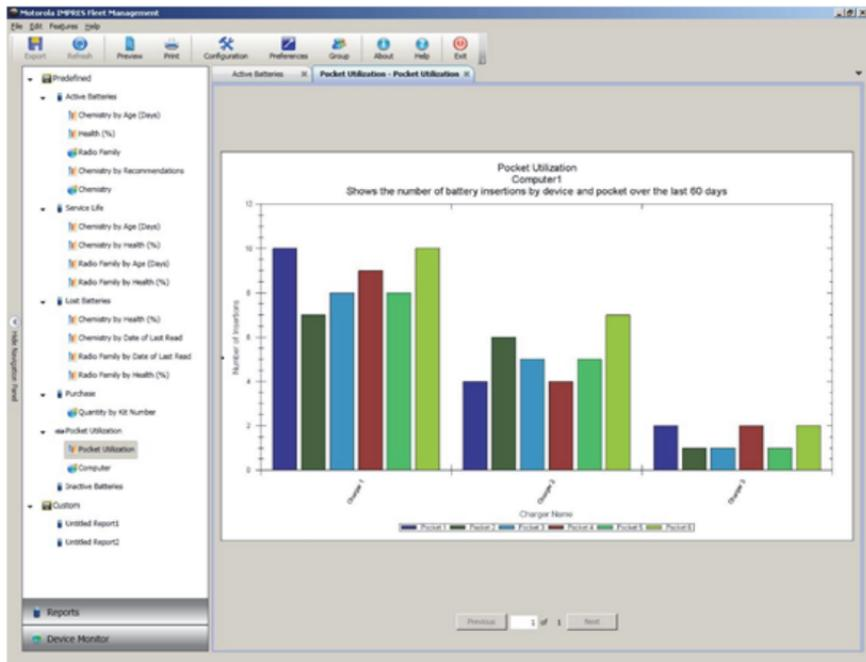

**경고**

- 이 벽 부착용 받침대는 경험이 많은 숙련 기술자가 설치해야 합니다. 비전문 기술자가 본 제품을 설치하는 것은 매우 위험하며 제품 손상 또는 부상을 초래할 수 있습니다.
- 무게를 지탱하지 못하는 곳에 제품을 설치하지 마십시오. 벽면 부착 장치가 설치되는 위치에서 무게를 지탱하는 힘이 부족할 경우 제품이 떨어져 부상을 입을 수 있습니다.
- 진동, 움직임 또는 충격이 발생할 수 있는 구조물에 설치하지 마십시오.

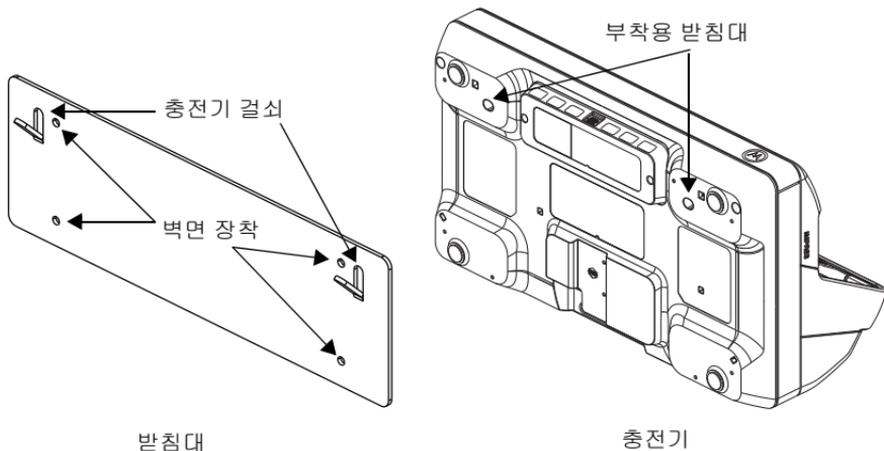

**그림 33:** 받침대 장착 구멍 및 걸쇠 위치

## 벽 부착용 받침대에 멀티 유닛 충전기 장착하기

1. 벽 부착용 받침대를 원하는 위치에 놓고 벽면에 장착 구멍의 위치를 표시합니다.



장착 나사를 깎고 드릴로 뚫거나 설치하기 전에 항상 장착 표면 뒤의 영역에 전기선, 케이블 및 파이프가 없는지 확인하십시오.

2. 장착되는 벽면 소재의 고정 유형에 맞는 적절한 장착 하드웨어를 사용하여 받침대를 벽에 장착합니다. 벽면에 표시한 장착 구멍 위치에서 드릴로 구멍을 뚫습니다.
3. 벽 부착용 받침대의 장착 구멍에 장착 하드웨어를 단단히 설치하여 벽 부착용 받침대를 제자리에 고정시킵니다.

**참고:** 나무 못과 단단한 평면 콘크리트/벽돌 벽에 10-16x1.5인치 태핑 나사와 와셔(포함되지 않음)를 사용하는 것이 좋습니다.

4. 벽 부착용 받침대에 멀티 유닛 충전기를 겁니다.

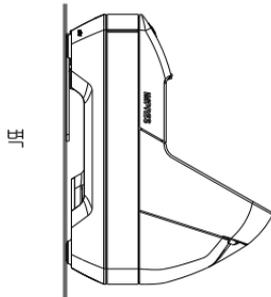

**그림 34:** 벽 부착용 받침대에 충전기 장착

# 메모

# WICHTIGE SICHERHEITSANWEISUNGEN

## Diese Anweisungen bitte aufbewahren

Dieses Dokument enthält wichtige Sicherheits- und Betriebsanweisungen. Lesen Sie diese Bedienungsanleitung sorgfältig durch, und bewahren Sie sie für eine spätere Verwendung auf.

Lesen Sie vor der Verwendung des Akkuladegeräts sämtliche Anweisungen und Warnhinweise auf (1) dem Ladegerät, (2) dem Akku und (3) dem Funkgerät, das diesen Akku verwendet.



1. Ziehen Sie beim Trennen von der Steckdose oder vom Ladegerät am Stecker (und nicht am Kabel), um Schäden am Stromkabel zu vermeiden.
2. Ein Verlängerungskabel sollte nur verwendet werden, wenn es unbedingt erforderlich ist. Die Verwendung eines ungeeigneten Verlängerungskabels kann das Risiko von Feuer oder Stromschlägen nach sich ziehen. Wenn die Verwendung eines Verlängerungskabels unerlässlich ist, vergewissern Sie sich, dass die Kabelgröße für Kabel mit einer Länge von max. 2,0 m der AWG-Stufe 18 und für Kabel mit einer Länge von max. 3,0 m der AWG-Stufe 16 entspricht.
3. Um das Risiko von Feuer, Stromschlägen oder Verletzungen zu minimieren, verwenden Sie das Ladegerät nicht in defektem oder beschädigtem Zustand. Wenden Sie sich an einen qualifizierten Kundendienstmitarbeiter von Motorola Solutions.
4. Nehmen Sie das Ladegerät nicht auseinander. Die Demontage des Ladegeräts kann zu Feuer oder Stromschlägen führen. Die einzigen reparierbaren Teile/Ersatzteile sind die Schaleneinsätze NNTN9212 und NNTN9213. Befolgen Sie die Anweisungen in MN005697A01 zu den Schaleneinsatzkits des Mehrfachladegeräts der APX-Serie IMPRES 2.
5. Ziehen Sie das Netzteil des Ladegeräts vor einer Wartung oder Reinigung aus der Steckdose, um Stromschläge zu vermeiden.
6. Um die Verletzungsgefahr zu minimieren, laden Sie nur von Motorola Solutions autorisierte Akkus auf (siehe Tabelle 2). Andere Akkus können explodieren sowie Personen- und Sachschäden verursachen.
7. Die Verwendung von Zubehör, das nicht von Motorola Solutions empfohlen wird, kann zu Bränden, Stromschlägen oder Verletzungen führen.

## Sicherheitsrichtlinien für den Betrieb

- Dieses Gerät ist nicht für die Verwendung im Freien geeignet. Verwenden Sie das Gerät nur in trockenen Umgebungen/Bedingungen.
- Die maximale Umgebungstemperatur um das Ladegerät darf 40 °C (104 °F) nicht übersteigen.
- Während sich ein Funkgerät in einer Ladeschale befindet, darf es nur dann eingeschaltet werden, wenn es Daten drahtlos überträgt, z. B. über WLAN. Schalten Sie das Funkgerät andernfalls aus.
- Schließen Sie das Ladegerät nur an ein entsprechendes Netzteil an, das in Tabelle 3 aufgeführt wird.
- Die Steckdose, an die das Netzkabel angesteckt ist, muss sich in der Nähe befinden und leicht zugänglich sein.
- Vergewissern Sie sich, dass das an das Ladegerät angeschlossene Netzteil so verlegt ist, dass niemand darauf treten oder darüber stolpern kann. Des Weiteren darf es weder mit Wasser in Berührung kommen, Zugkräften ausgesetzt oder beschädigt werden.
- Schließen Sie das Netzkabel nur an eine ordnungsgemäß gesicherte und verkabelte Steckdose mit korrekter Spannung, entsprechend den Angaben auf dem Gerät, an.
- Trennen Sie die Verbindung zur Netzspannung, indem Sie das Netzkabel aus der Steckdose ziehen.
- Verbinden Sie nicht mehr als die zulässige Anzahl an Ladegeräten mit einem Stromkreis mit 15 A oder 20 A, wie durch eine beliebige zugelassene Steckdosenleiste begrenzt. Die Serienschaltung von Steckdosenleisten wird NICHT EMPFOHLEN. Begrenzen Sie die Stromkreisbelastung auf unter 80 % des Nennwerts.
- Verwenden Sie nur von Motorola Solutions zugelassene Ladeschalen.

# Unterstützte Modelle

**Tabelle 1:** Unterstützte Modelle und Beschreibung

Modell	Beschreibung
PS000029A01 (UNIV) PS000029A04 (EU/UK) PS000029A06 (RK)	APX IMPRES 2-Mehrfachladegerät mit 1 Display, Ladegerät-Neuprogrammierung und Flottenverwaltung
PS000029A02 (UNIV) PS000029A05 (EU/UK) PS000029A07 (RK)	APX IMPRES 2-Mehrfachladegerät mit 6 Displays, Ladegerät-Neuprogrammierung und Flottenverwaltung
PS000029A03 (EU/UK) PS000029A08 (RK)	APX IMPRES 2-Mehrfachladegerät mit 6 Displays, Ladegerät-Neuprogrammierung, Flottenverwaltung und USB-Zubehör zum Aufladen
PS000337A01 (USA/Nordamerika, AU/ NZ)	APX NEXT IMPRES 2-Mehrfachladegerät mit 6 Displays, Ladegerät-Neuprogrammierung und Flottenverwaltung

## Von Motorola Solutions autorisierte Akkus

Die IMPRES 2-Ladegeräte der APX-Serie laden die Akkus, die in Tabelle 2 aufgeführt werden. Die Akkus sind entweder mit dem Funkgerät verbunden oder eigenständig.

**Tabelle 2:** Von Motorola Solutions autorisierte Akkus

Kit (PN)	Beschreibung
NNTN7033	IMPRES Lithium-Ionen-Akku, FM (HazLoc), IP67, 4.100 mAh
NNTN7034	IMPRES Lithium-Ionen-Akku, IP67, 4.200 mAh
NNTN7035	IMPRES NiMH-Akku, FM (HazLoc), robust, 2.000 mAh
NNTN7036	IMPRES NiMH-Akku, FM (HazLoc), IP67, 2.000 mAh
NNTN7037	IMPRES NiMH-Akku, IP67, 2.100 mAh
NNTN7038	IMPRES Lithium-Ionen-Akku, IP67, 2.900 mAh
NNTN7573	IMPRES NiMH-Akku, robust, 2.100 mAh
NNTN8092	IMPRES Lithium-Ionen-Akku, FM (HazLoc), robust, 2.300 mAh
NNTN8182	IMPRES Lithium-Ionen-Akku, robust, 2.900 mAh
NNTN8921	IMPRES 2 Lithium-Ionen-Akku, TIA4950 (HazLoc), robust, IP67, 3.700 mAh



**Tabelle 2: Von Motorola Solutions autorisierte Akkus (Forts.)**

Kit (PN)	Beschreibung
NNTN8930	IMPRES 2 Lithium-Ionen-Akku, TIA4950 (HazLoc), robust, IP67, 2.700 mAh
NNTN9087	IMPRES 2 Lithium-Ionen-Akku, IP68, 3.800 mAh
NNTN9088	IMPRES 2 Lithium-Ionen-Akku, DIVISION 2 (HazLoc), IP68, 3.800 mAh
NNTN9089	IMPRES 2 Lithium-Ionen-Akku, IP68, 5.650 mAh
NNTN9090	IMPRES 2 Lithium-Ionen-Akku, DIVISION 2 (HazLoc), IP68, 5.650 mAh
NNTN9126	IMPRES 2 Lithium-Ionen-Akku, IP68, 4.400 mAh
NNTN9127	IMPRES 2 Lithium-Ionen-Akku, DIVISION 2 (HazLoc), IP68, 4.400 mAh
PMNN4403	IMPRES Lithium-Ionen-Akku, IP67, 2.150 mAh
PMNN4485	IMPRES 2 Lithium-Ionen-Akku, robust, IP67, 2.500 mAh
PMNN4486	IMPRES 2 Lithium-Ionen-Akku, robust, IP67, 3.400 mAh
PMNN4487	IMPRES 2 Lithium-Ionen-Akku, robust, IP67, 4.400 mAh
PMNN4494	IMPRES 2 Lithium-Ionen-Akku, robust, IP67, 5.000 mAh
PMNN4504	IMPRES 2 Lithium-Ionen-Akku, DIVISION 2 (HazLoc), robust, IP67, 3.400 mAh
PMNN4505	IMPRES 2 Lithium-Ionen-Akku, DIVISION 2 (HazLoc), robust, IP67, 4.850 mAh
PMNN4547	IMPRES 2 Lithium-Ionen-Akku, TIA4950 (HazLoc), robust, IP68, 3.100 mAh
PMNN4573	IMPRES 2 Lithium-Ionen-Akku, TIA4950 (HazLoc), robust, IP68, 4.600 mAh
PMNN4812	APX NEXT XN IMPRES 2 Lithium-Ionen-Akku, DIV 2 (HAZLOC), IP68, 3.400 mAh

## Von Motorola Solutions autorisierte Netzteile

**Tabelle 3: Von Motorola Solutions autorisierte Netzteile**

Kit (PN)	Beschreibung
3087791G01	Netzkabel, US/NA
3087791G04	Netzkabel, EU
3087791G07	Netzkabel, UK/HK
3087791G10	Netzkabel, AU/NZ
3087791G13	Netzkabel, AR
3087791G16	Netzkabel, KR
3087791G20	Netzkabel, JP
3087791G22	Netzkabel, BR

**Tabelle 3:** Von Motorola Solutions autorisierte Netzteile

Kit (PN)	Beschreibung
CB000460A01	Netzkabel, CH

## Von Motorola Solutions autorisierte Kommunikationsmodule

**Tabelle 4:** Von Motorola Solutions autorisierte Kommunikationsmodule

Kit (PN)	Beschreibung
Da000013A01	IMPRES 2 Ladegerät-Neuprogrammierung und Akku-Managementmodul
Da000012A02	IMPRES 2 Ladegerät-Neuprogrammierung/Akku-Management und Zubehörladmodul

## Ladegerät, Ladeschale und Kommunikationsmodul

Das adaptive IMPRES 2™-Ladesystem der APX-Serie ist ein voll automatisiertes Akkupflegesystem. Das Ladegerät verfügt über die folgenden Funktionen:

- Adaptives Laden für ein breites Spektrum an Akkutypen, einschließlich IMPRES 2™-, IMPRES™- und anderer Original-Akkus von Motorola Solutions.
- Ladeschale für einen separaten Akku oder ein Funkgerät mit eingesetztem Akku.
- LED-Anzeige mit rot/orange/grün zeigt Ladeschalenstatus an.
- Kommunikationsmodul
  - Ladegerät-Neuprogrammierung
  - Upload der IMPRES 2- oder IMPRES-Akkudaten in ein IMPRES Battery Fleet Management-System
  - (Optional) Sechs Ladeanschlüsse vom Typ USB Typ A, jeweils mit 0,5 A zum Laden von USB-Zubehör
- Tastaturmenü
  - Einrichtung Ladegerät
  - Akkuanalyse
- Informationsdisplay auf Ladeschale 1.
  - Optionale Displays an anderen Ladeschalen

- Vorbereitung eines eigenständigen IMPRES 2- oder IMPRES-Akkus für die Langzeitaufbewahrung oder Vorbereitung eines eigenständigen Lithium-Ionen-Akkus von Motorola Solutions für den Versand. Lassen Sie die Akkus NICHT im Ladegerät, nachdem die Langzeitaufbewahrung vorbereitet bzw. der Versand der Lithium-Ionen-Akkus erfolgt ist.
- Funktionen für mehr Energieeffizienz
  - Entspricht den Normen der California Energy Commission für kleine Akkuladesysteme – Ladeschalen wechseln automatisch in den Energiesparmodus und werden bei Benutzereingaben oder für Wartungsarbeiten an einem Akku in der Ladeschale reaktiviert.
  - Entspricht den europäischen Ruhestromgrenzen (europäisches Ladegerätekit). Wenn der Energiesparmodus aktiviert ist, schalten sich alle Ladeschalen außer Ladeschale 1 automatisch aus, wenn für einen gewissen Zeitraum keine Aktivität stattfindet. Die Schalen können durch Drücken einer beliebigen Taste auf der Tastatur wieder aktiviert werden.
- Höhere Laderate für den IMPRES 2-Lithium-Ionen-Akku.
- Schnellere Ladung.
- Verlängerte Akku-Lebensdauer.

Der Betrieb eines Funkgeräts im Ladegerät wird nicht empfohlen.

Während des Ladevorgangs kann der Betrieb des Funkgeräts zu minimalen Leistungseinbußen sowie zu verlängerten Akkuladezeiten führen.

Während der Kalibrierung/Wiederaufarbeitung wird der Akku vollständig entladen, bevor er vollständig aufgeladen wird. Infolgedessen wird das Funkgerät während der Entladung möglicherweise ausgeschaltet. Es wird empfohlen, den Akku ohne angeschlossenes Funkgerät oder bei ausgeschaltetem angeschlossenen Funkgerät zu kalibrieren.

## **IMPRES 2- und IMPRES-Akkus und -Ladegeräte**

### **Funktionen und Vorteile**

Die IMPRES 2-Stromversorgungslösung ist ein fortschrittliches Energiesystem für drei verschiedene chemische

Zusammensetzungen, das von Motorola Solutions entwickelt wurde. Dieses System umfasst:

- IMPRES 2- und IMPRES-Akkus
- Adaptives IMPRES 2-Ladegerät
- IMPRES-Funkgeräte

Werden IMPRES 2- oder IMPRES-Akkus mit einem adaptiven IMPRES 2-Ladegerät geladen, das den Akku regelmäßig kalibriert/aufbereitet, entstehen folgende Vorteile:

- Verlängerung der Akkulebensdauer
- Misst die Akkukapazität und bestimmt den aktuellen Ladezustand des Akkus, sodass Sie eine Anzeige der effektiven Nutzungszeit erhalten.
- Überwachung des Nutzungsmusters des IMPRES 2- oder IMPRES-Akkus
- Aktualisierung der im IMPRES 2- oder IMPRES-Akku gespeicherten Informationen zu den Mustern
- Automatische Kalibrierung/Wiederaufarbeitung nur bei Bedarf
- Minimierung der Erwärmung des IMPRES 2- oder IMPRES-Akkus unabhängig davon, wie lange der Akku in der Ladeschale verbleibt
- Regelmäßiges Aufladen des Akkus in der Ladeschale, sodass er immer einsatzbereit ist
- Beseitigung des Memoryeffekts bei Nickel-Akkus – dadurch entfällt die Notwendigkeit des Erwerbs besonderer Ausrüstung oder Schulung der Mitarbeiter in Aufgaben zur Aufrechterhaltung der Akkulebensdauer

Mit diesem einzigartigen patentierten System müssen Sie die Nutzung von IMPRES 2- oder IMPRES-Akkus nicht nachverfolgen und erfassen, keine manuelle Kalibrierung/Aufbereitung durchführen oder Akkus nach dem Laden aus dem Ladegerät nehmen.

## **IMPRES 2- oder IMPRES-Akkuinitialisierung**

Für volle IMPRES 2- oder IMPRES-Funktionalität muss ein neuer IMPRES 2- oder IMPRES-Akku durch das Ladegerät initialisiert werden. Das Ladegerät erkennt den neuen IMPRES 2- oder IMPRES-Akku automatisch und beginnt automatisch mit der Initialisierung. Die Initialisierung stellt die erste IMPRES-Akku-Kalibrierung/Aufbereitung eines IMPRES 2- oder IMPRES-Akkus dar. Hierfür sind zwei Schritte erforderlich. In der ersten Phase wird der Akku entladen, und die LED

leuchtet **konstant gelb**. In der zweiten Phase wird der Akku voll aufgeladen, und die LED leuchtet **konstant grün**. Dieser Prozess kann bis zu 12 Stunden oder länger dauern, je nach Ladestatus und Kapazität des Akkus. Wird eine der Phasen unterbrochen, wird die Initialisierung bis zur nächsten Gelegenheit verschoben.

## **IMPRES 2- oder IMPRES-Ladeschalenüberwachung**

Während des Ladens von IMPRES 2- oder IMPRES-Akkus zeichnet das IMPRES 2- oder IMPRES-Ladegerät Aufladeinformationen innerhalb des Akkuspeichers auf. Wenn der IMPRES 2- oder IMPRES-Akku aus einer IMPRES 2- oder IMPRES-Ladeschale entnommen und innerhalb von 30 Minuten in andere oder die gleiche IMPRES 2- oder IMPRES-Ladeschale eingesetzt wird, wird der Ladevorgang an dem Punkt fortgesetzt, an dem er unterbrochen wurde. Diese Funktion verhindert eine Überladung und minimiert die Abnahme der Lebensdauer. Dies ist besonders beim Laden von Nickelakkus wichtig.

## **Automatische IMPRES 2- oder IMPRES-Kalibrierung/ Aufbereitung von Akkus**

Das IMPRES 2-Ladegerät beurteilt automatisch den Zustand eines IMPRES 2- oder IMPRES-Akkus. Auf der Grundlage dieser Bedingung wechselt das Ladegerät automatisch zur Kalibrierung/Wiederaufarbeitung des Akkus. Unterbrechung der Entladephase bzw. der Ladephase verzögern die Initialisierung bis zu nächsten Gelegenheit.

Verwenden Sie den Einrichtungsmodus des Ladegeräts, um die Kalibrierung/Aufbereitung zu aktivieren oder zu deaktivieren. Wenn diese Option deaktiviert ist und der IMPRES 2- oder IMPRES-Akku kalibriert/aufbereitet werden muss, blinkt die LED bei Einsetzen des Akkus und nach der vollständigen Aufladung des Akkus **abwechselnd gelb und grün**.

**Hinweis:** Der IMPRES 2- oder IMPRES-Akku muss sich für eine automatische Kalibrierung/Aufbereitung länger als 30 Minuten außerhalb der Ladeschale befinden.

## IMPRES-Akkus mit Selbstkalibrierung und -wiederaufarbeitung



**ACHTUNG!** IMPRES 2-Akkus, die dieses Symbol auf dem Akkuetikett tragen, brauchen keine regelmäßige Kalibrierung und Rekonditionierung, wenn sie an dieses IMPRES 2-Ladegerät (mit Softwareversion V2.05 oder höher) angedockt sind.

**Hinweis:** Stellen Sie sicher, dass Ihr Ladegerät immer mit der neuesten Firmware aktualisiert wird. Das Anwendungspaket MSI Charger Reprogrammer kann von der MOL-Website (Motorola Online) oder Motorola Solutions-Website heruntergeladen werden.

### Firmware aktualisieren

**Hinweis:** Gilt für alle IMPRES-Geräte des Typs Gen 1 und Gen 2 oder Ladegeräte; dazu gehören die Charger Interface Unit (CIU), der Battery Data Reader (BDR), das Einzelladegerät (SUC), das Zweifachladegerät (DUC) und das Mehrfachladegerät (MUC).

Entfernen Sie alle eingelegten Akkus aus dem Zielgerät oder Ladegerät, bevor Sie ein IMPRES-Gerät oder -Ladegerät auf eine neuere Version aktualisieren.

1. Schließen Sie das Gerät oder Ladegerät über USB an Ihren Computer an. Das angeschlossene Gerät oder Ladegerät wird im Hauptfenster des MSI Charger Reprogrammers angezeigt.

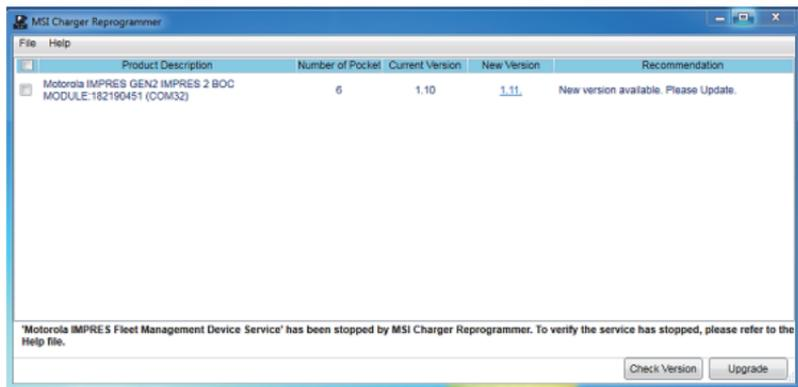

2. Klicken Sie auf Version prüfen, um die neueste verfügbare Version auf dem MSI-Server zu finden.

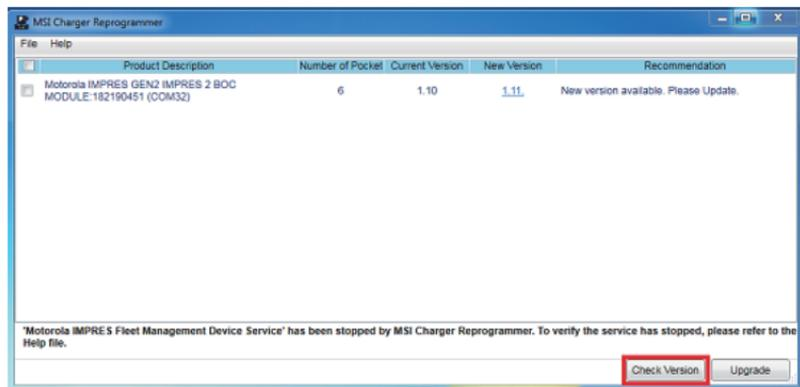

3. Wählen Sie das Gerät oder Ladegerät aus, das aktualisiert werden muss.

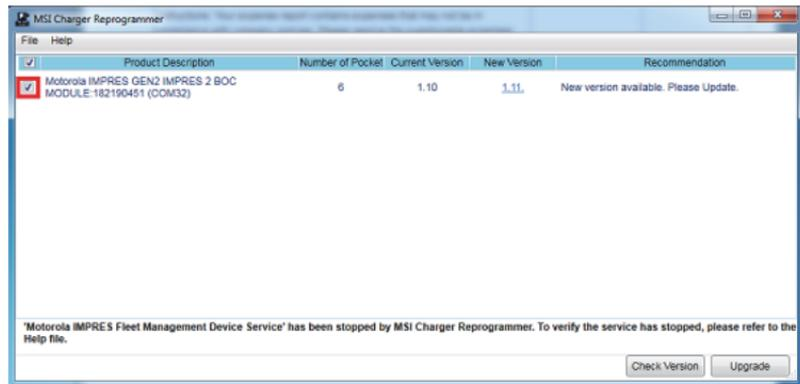

**Hinweis:** Sie können kein Gerät oder Ladegerät auswählen, das bereits mit der neuesten Firmware-Version aktualisiert wurde.

4. Klicken Sie zum Starten der Firmware-Aktualisierung auf „Upgrade“.

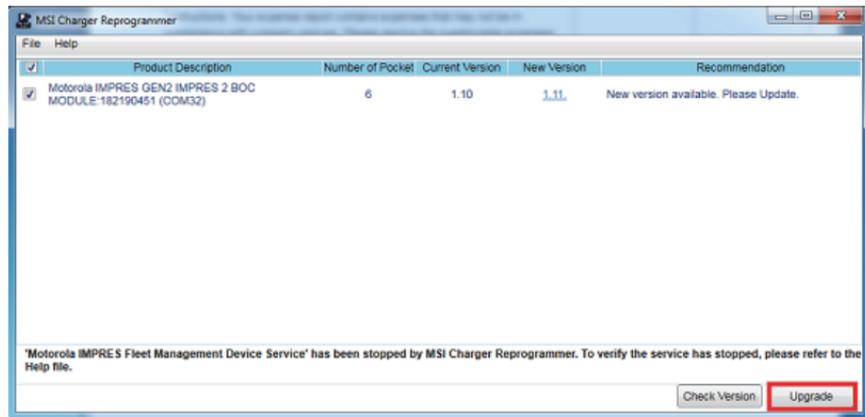



5. Klicken Sie im Bestätigungsfenster auf „OK“, wenn Sie dazu aufgefordert werden, die Aktualisierung zu starten. Ein Fenster zeigt den Fortschritt der Aktualisierung bis zum Abschluss an.

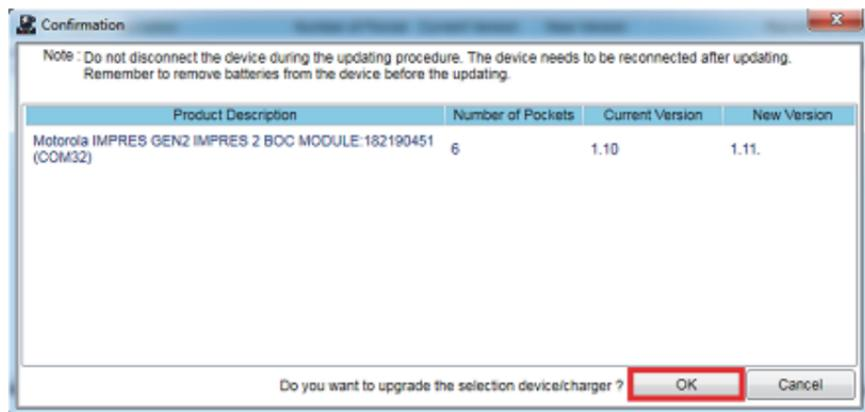

6. Schließen Sie das Fenster, sobald alle Aktualisierungen abgeschlossen sind.

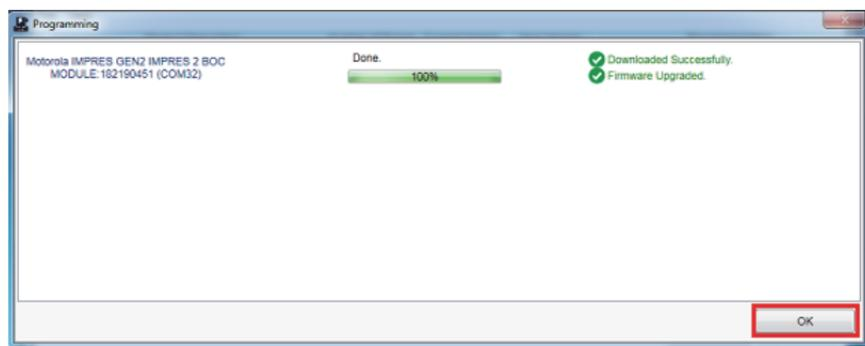

## Manuelles Initiieren der Kalibrierung/Wiederaufarbeitung



**ACHTUNG:** Manuelle Kalibrierung oder Wiederaufbereitung ist bei IMPRES- oder IMPRES 2-Akkus mit diesem Symbol nicht möglich.

Obwohl die Kalibrierung/Wiederaufarbeitung automatisch erfolgt, kann es zu Situationen kommen, in denen eine manuelle Einleitung gewünscht ist. Beispielsweise blinkt die LED des Ladegeräts möglicherweise **abwechselnd gelb und grün** beim IMPRES 2- oder IMPRES-Akku, um anzuzeigen, dass die Kalibrierungsfunktion des Ladegeräts deaktiviert ist. Wenn dieser Akku innerhalb von 30 Minuten in ein Ladegerät eingesetzt wird, bei dem die Kalibrierungsfunktion aktiviert ist, wird der letzte Ladezustand fortgesetzt, um einen automatischen Start des Kalibrierungs-/Aufbereitungsvorgangs zu vermeiden.

Um die Kalibrierung/Aufbereitung manuell zu starten, entfernen Sie den IMPRES 2- oder IMPRES-Akku für länger als zweieinhalb Minuten aus dem Ladegerät. Führen Sie anschließend die folgenden Schritte aus:

1. Setzen Sie den Akku in die Ladeschale ein.
2. Entnehmen Sie den Akku innerhalb von 2,5 Minuten aus der Ladeschale.
3. Setzen Sie den Akku innerhalb von 5 Sekunden wieder in die Ladeschale ein.

Kalibrierung/Wiederaufarbeitung beginnt sofort, meist mit der Entladung (**gelbes Leuchten**). Kalibrierung/Wiederaufarbeitung ist erst nach vollständiger Ladung (**konstantes grünes Leuchten**) abgeschlossen.

### **Manuelles Beenden der Kalibrierung/Wiederaufarbeitung**

Während der Entladung des IMPRES 2- oder IMPRES-Akkus (LED leuchtet konstant gelb) kann die Kalibrierung/Aufbereitung wie folgt beendet werden:

1. Entfernen Sie den Akku aus dem Ladegerät und der Ladeschale.
2. Setzen Sie den Akku innerhalb von 5 Sekunden wieder in die Ladeschale ein.

Die Akkuentladung wird sofort beendet, und der normale Ladevorgang beginnt. Die LED-Anzeige zeigt den Ladezustand des Akkus an.

# Ladegerät – Übersicht



Abbildung 1: Ladegerät – Übersicht

Tabelle 5: Ladegerät – Übersicht und Beschreibung

Nr.	Name	Beschreibung
1-6	Ladeschalen	Jede Ladeschale bietet Platz für ein kompatibles Funkgerät oder einen eigenständigen Akku
7	Kommunikationsmodul	Bei bestimmten Ladegeräten kann über das Kommunikationsmodul auch folgendes USB-Zubehör aufgeladen werden: <ul style="list-style-type: none"> <li>• EU/UK PS000029A03</li> <li>• RK PS000029A08</li> </ul>
8	LED-Statusanzeige der Ladeschale	Ladestatus-LED (eine pro Ladeschale)
9	Anzeige	Optionales Display für andere Ladeschalen als Ladeschale 1
10	Tastaturdisplay	Display von Ladeschale 1 mit Menü-Tastatur
11	AC-Steckdose	Verwendet länder- oder regionenspezifisches Netzkabel

## IMPRES 2- oder IMPRES-LED-Anzeige der Akkulebensdauer

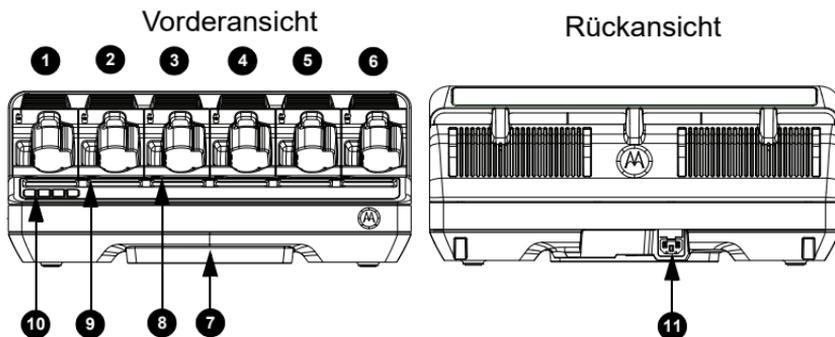
Das Ladegerät kann bei erfolgreichem Abschluss der Kalibrierung/ Aufbereitung das Ende der Lebensdauer des IMPRES 2- oder IMPRES-Akkus (**abwechselnd rot/grün**) anzeigen.

Die normale Akkunuzung reduziert die verfügbare Kapazität. Nach der erfolgreichen Kalibrierung/Aufbereitung vergleicht das Ladegerät die IMPRES 2- oder IMPRES-Akkukapazität mit der Nennkapazität des Akkus. Ist die Kapazität sehr niedrig, nähert sich der IMPRES 2- oder IMPRES-Akku möglicherweise dem Ende seiner Lebensdauer. Der IMPRES 2- oder IMPRES-Akku kann weiterhin verwendet werden. In manchen Fällen ist es möglicherweise sinnvoll, den Akku an jemanden zu geben, der bis zum Ende seiner Schicht keine große Speicherkapazität mehr benötigt.

Der APX NEXT XN-Akku verfügt über eine Funktion zur Erkennung von hohen Temperaturen, die vom IMPRES 2-Ladegerät mit der Softwareversion V2.05 oder höher erkannt werden kann. Wenn diese Funktion aktiviert ist, blinkt die Status-LED abwechselnd rot und grün, wenn der Ladezustand abgeschlossen ist und der Akku für längere Zeit extrem hohen Temperaturen ausgesetzt war. Das Ladegerät zeigt Folgendes an:

REPLACE BATTERY  
EXPOSED OVERTEMP

Es wird empfohlen, diesen Akku zu entfernen und nicht mehr zu verwenden.

## Aufladen von Akkus oder Funkgeräten mit angeschlossenen Akkus

Akkus werden am besten bei Raumtemperatur aufgeladen. IMPRES 2-Mehrfachladegeräte können einen eigenständigen Akku oder einen Akku, der an ein Funkgerät angeschlossen ist, aufladen.

1. Legen Sie das Mehrfachladegerät auf eine ebene Fläche.
2. Stecken Sie das Netzkabel fest in die Buchse auf der Rückseite des Ladegeräts ein.
3. Stecken Sie das Netzkabel in eine passende Steckdose.
4. Nach erfolgreichem Einschalten blinkt jede Ladestatus-LED ca. eine Sekunde lang **grün**, und **IMPRES 2 CHARGER** wird angezeigt. Wenn die Ladestatus-LED nicht blinkt und keine Meldung angezeigt wird, prüfen Sie, ob die Netzkabel korrekt eingesteckt sind.
5. Legen Sie ein Funkgerät mit angeschlossenem Akku oder einen eigenständigen Akku in eine verfügbare Ladeschale.

**Hinweis:** Halten Sie das Gehäuse des Funkgeräts fest, wenn Sie es in das Ladegerät einsetzen bzw. daraus entfernen. Ziehen Sie nicht an der Funkgeräntenne.

6. Wenn das Funkgerät oder der Akku ordnungsgemäß in die Ladeschale eingelegt ist, zeigt die dazugehörige Ladestatus-LED den Ladestatus an. Das dazugehörige Display bietet zusätzliche Informationen. Bei Einzeldisplay-Ladegeräten zeigt das Display nur den Ladestatus von Ladeschale 1 an.
7. Der Akku ist bereit zur Verwendung, wenn die Ladestatus-LED **konstant grün** leuchtet.
8. Schalten Sie das Funkgerät nur ein, wenn das Kommunikationsmodul des Ladegeräts nicht an einen PC angeschlossen ist. Schalten Sie andernfalls das Gerät oder Funkgerät aus.

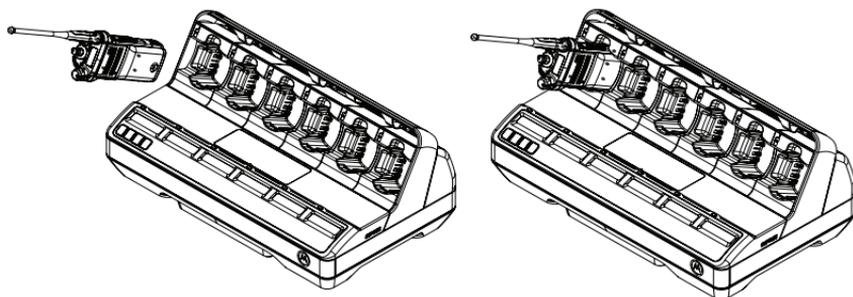

**Abbildung 2:** Aufladen eines an ein Funkgerät angeschlossenen Akkus

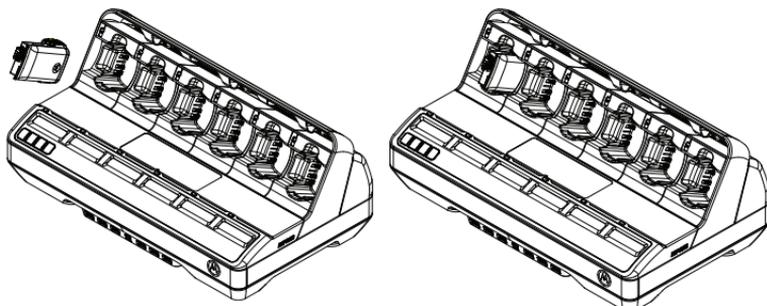

**Abbildung 3:** Aufladen eines eigenständigen Akkus

## Aufladen von USB-Zubehör

Einige IMPRES 2-Mehrfachladegerät-Kommunikationsmodule bieten USB-Ports vom Typ A zum Aufladen von USB-Zubehör. USB-Zubehörteile werden am besten bei Raumtemperatur aufgeladen.

1. Legen Sie das adaptive IMPRES 2-Ladegerät auf einer ebenen Oberfläche ab.
2. Stecken Sie das Netzkabel fest in die Buchse auf der Rückseite des Ladegeräts ein.
3. Stecken Sie das Netzkabel in eine passende Steckdose.
4. Nach erfolgreichem Einschalten blinkt jede Status-LED an der Ladeschale für eine Sekunde **grün** und `IMPRES 2 CHARGER` wird angezeigt. Wenn die Status-LEDs nicht blinken und keine Meldung angezeigt wird, prüfen Sie, ob das Netzkabel korrekt eingesteckt ist.
5. USB-Zubehör kann über eine Mikro-AB-Buchse zum Aufladen verfügen. Verwenden Sie ein standardmäßiges USB-Kabel von 1 Meter Länge oder weniger mit einem Typ-A-Stecker an einem Ende und einem zum Zubehör passenden Stecker am anderen Ende.
6. Richten Sie das USB-Kabel Typ A sorgfältig an einem Typ A-Anschluss am Kommunikationsmodul aus. Stecken Sie den Stecker in den Anschluss.
7. Richten Sie das USB-Kabel mit Mikro-B-Stecker sorgfältig an der Mikro-AB-Buchse des USB-Zubehörs aus. Stecken Sie den Stecker in die Buchse.
8. Wenn die USB-Anschlüsse ordnungsgemäß angeschlossen sind, wird der Ladezustand vom USB-Zubehör angezeigt. Eine detaillierte Beschreibung hierzu finden Sie in der Dokumentation USB-Benutzerhandbuch.

## Ladeanzeigen

**Tabelle 6:** Ladeanzeigen für IMPRES 2- oder IMPRES-Akkus – keine Kalibrierung erforderlich

Status	Ladeschalen-Display	LED-Anzeige
Ladegerät schaltet sich ein	IMPRES 2 CHARGER	Ca. 1 Sekunde lang grün 
Akku erkannt	IMPRES 2 AKKU ODER IMPRES AKKU	Konstant rot 
Schnellladung	RAPID CHARGE xxxxx0mAh yy%Pt1	Konstant rot 
Zu 90 % oder mehr geladen	TRICKLE CHARGE xxxxx0mAh yy%Pt1	Grün blinkend 
Zu 95 % oder mehr geladen	CHARGE COMPLETE xxxxx0mAh yy%Pt1	Konstant grün 
Störung	WARNING: NOT CHARGEABLE REMOVE & REINSERT	Rot blinkend 
Standby • Akku wartet auf Schnellladung. • Akku ist zu heiß, zu kalt oder Spannung zu niedrig. • Ladegerät ist zu heiß.	WARNING: HOT BATTERY WAITING TO CHARGE ODER COLD BATTERY WAITING TO CHARGE ODER VERY LOW BATTERY WAITING TO CHARGE ODER HOT CHARGER WAITING TO CHARGE	Gelb blinkend 

### Hinweis:

- Die Meldung **Hot Charger** wird in der Software V1.05 eingeführt.
- Der Zustand der Prozentanzeigen des Ladegeräts im Hinblick auf die potenzielle Kapazität im Vergleich zur Nennkapazität wird in der Software V1.11.01 eingeführt.

**Tabelle 7: Ladeanzeigen für IMPRES 2- oder IMPRES-Akkukalibrierung – Kalibrierung aktiviert**

Status	Ladeschalen-Display	LED-Anzeige
Ladegerät schaltet sich ein	IMPRES 2 CHARGER	Ca. 1 Sekunde lang grün 
Akku erkannt	IMPRES 2 AKKU ODER IMPRES AKKU	Konstant gelb 
Akku entlädt	CAL DISCHARGE xxxxx0mAh yyyz%Pt1	Konstant gelb 
Schnellladung	CAL RAPID CHARGE xxxxx0mAh yyyz%Pt1	Konstant rot 
Zu 90 % oder mehr geladen	CAL TRICKLE CHARGE xxxxx0mAh yyyz%Pt1	Grün blinkend 
Zu 95 % oder mehr geladen	CHARGE COMPLETE xxxxx0mAh yyyz%Pt1	Akkukalibrierung erfolgreich: Konstant grün   Akkukalibrierung erfolgreich, Lebensdauer möglicherweise bald abgelaufen (Akku ist nutzbar): Rot/Grün blinkend 
	REPLACE BATTERY EXPOSED OVERTEMP	Die Akkukalibrierung war erfolgreich, aber der Akku wurde einer kumulativen Übertemperatur ausgesetzt (wir empfehlen, diesen aus der Flotte zu entfernen): Rot/grün blinkend HINWEIS: Gilt nur für den APX NEXT XN-Akku 
Störung	WARNING: NOT CHARGEABLE REMOVE & REINSERT	Rot blinkend 



**Tabelle 7:** Ladeanzeigen für IMPRES 2- oder IMPRES-Akkukalibrierung – Kalibrierung aktiviert (Forts.)

Status	Ladeschalen-Display	LED-Anzeige
<p>Standby</p> <ul style="list-style-type: none"> <li>• Akku wartet auf Schnellladung.</li> <li>• Akku ist zu heiß, zu kalt oder Spannung zu niedrig.</li> <li>• Ladegerät ist zu heiß.</li> </ul>	<p>WARNUNG: HOT BATTERY WAITING TO CAL ODER COLD BATTERY WAITING TO CAL ODER VERY LOW BATTERY WAITING TO CHARGE ODER HOT CHARGER WAITING TO CAL</p>	<p>Gelb blinkend</p> 

**Tabelle 8:** Ladeanzeigen für IMPRES 2- oder IMPRES-Akkukalibrierung – Kalibrierung zunächst deaktiviert, anschließend aktiviert

Status	Ladegerät-Display	LED-Anzeige
Ladegerät schaltet sich ein	IMPRES 2 CHARGER	Ca. 1 Sekunde lang grün 
Akku erkannt	IMPRES 2 AKKU oder IMPRES AKKU	Akku erfordert eine Kalibrierung, aber Kalibrierung ist deaktiviert am Ladegerät: Abwechselnd gelb und grün für 4 Sekunden 
Anfordern einer IMPRES-Akkukalibrierung <ul style="list-style-type: none"> <li>Die Kalibrierung ist am Ladegerät deaktiviert.</li> <li>Der Akku wird geladen</li> </ul>	WARNUNG: ENABLE BATTERY CALIBRATION? <ul style="list-style-type: none"> <li>Wählen Sie zum Aktivieren der Kalibrierung OK</li> <li>Ignorieren Sie das beim normalen Laden (Nachricht verschwindet nach 1 Minute)</li> </ul>	Konstant rot 
Akku entlädt <ul style="list-style-type: none"> <li>OK ausgewählt</li> </ul>	CAL DISCHARGE xxxxx@mAh yyy%P t1	Konstant gelb 
Schnellladung	CAL RAPID CHARGE xxxxx@mAh yyy%P t1	Konstant rot 
Zu 90 % oder mehr geladen	CAL TRICKLE CHARGE xxxxx@mAh yyy%P t1	Grün blinkend 

**Tabelle 8:** Ladeanzeigen für IMPRES 2- oder IMPRES-Akkukalibrierung – Kalibrierung zunächst deaktiviert, anschließend aktiviert (Forts.)

Status	Ladegerät-Display	LED-Anzeige
Zu 95 % oder mehr geladen	CHARGE COMPLETE xxxxx0mFäh yyy%P t1	Akkukalibrierung erfolgreich: Konstant grün   Akkukalibrierung erfolgreich, Lebensdauer möglicherweise bald abgelaufen (Akku ist nutzbar): Rot/Grün blinkend 
	REPLACE BATTERY EXPOSED OVERTEMP	Die Akkukalibrierung war erfolgreich, aber der Akku wurde einer kumulativen Übertemperatur ausgesetzt (wir empfehlen, diesen aus der Flotte zu entfernen): Rot/grün blinkend HINWEIS: Gilt nur für den APX NEXT XN-Akku 
Störung	WARNUNG: HOT CHARGEABLE REMOVE & REINSERT	Rot blinkend 
Standby • Akku wartet auf Schnellladung. • Akku ist zu heiß, zu kalt oder Spannung zu niedrig. • Ladegerät ist zu heiß.	WARNUNG: HOT BATTERY WAITING TO CAL ODER COLD BATTERY WAITING TO CAL ODER VERY LOW BATTERY WAITING TO CHARGE ODER HOT CHARGER WAITING TO CAL	Gelb blinkend 

**Tabelle 9:** Ladeanzeigen für IMPRES 2- oder IMPRES-Akkus – Kalibrierung erforderlich, aber nicht aktiviert

Status	Ladegerät-Display	LED-Anzeige
Ladegerät schaltet sich ein	IMPRES 2 CHARGER	Ca. 1 Sekunde lang grün 
Akku erkannt	IMPRES 2 AKKU oder IMPRES AKKU	Akku erfordert eine Kalibrierung, aber Kalibrierung ist deaktiviert am Ladegerät: Abwechselnd gelb und grün für 4 Sekunden 
Anfordern einer IMPRES- Akkukalibrierung <ul style="list-style-type: none"> <li>Die Kalibrierung ist am Ladegerät deaktiviert.</li> <li>Der Akku wird geladen.</li> </ul>	<b>WARNUNG:</b> ENABLE BATTERY CALIBRATION? <ul style="list-style-type: none"> <li>Wählen Sie zum Aktivieren der Kalibrierung OK</li> <li>Ignorieren Sie das beim normalen Laden (Nachricht verschwindet nach 1 Minute).</li> </ul>	Konstant rot 
Schnellladung <ul style="list-style-type: none"> <li>Anforderung für Zeitüberschreitung der Kalibrierung.</li> </ul>	RAPID CHARGE xxxxx@mAh yyy%P t1	Konstant rot 
Zu 90 % oder mehr geladen	TRICKLE CHARGE xxxxx@mAh yyy%P t1	Grün blinkend 
Zu 95 % oder mehr geladen	CHARGE COMPLETE xxxxx@mAh yyy%P t1	Abwechselnd gelb/grün 
Störung	<b>WARNUNG:</b> NOT CHARGEABLE REMOVE & REINSERT	Rot blinkend 
Standby <ul style="list-style-type: none"> <li>Akku wartet auf Schnellladung.</li> <li>Akku ist zu heiß, zu kalt oder Spannung zu niedrig.</li> <li>Ladegerät ist zu heiß.</li> </ul>	<b>WARNUNG:</b> HOT BATTERY WAITING TO CHARGE ODER COLD BATTERY WAITING TO CHARGE ODER VERY LOW BATTERY WAITING TO CHARGE ODER HOT CHARGER WAITING TO CHARGE	Gelb blinkend 

**Tabelle 10:** Ladeanzeigen für voll aufgeladene IMPRES 2- oder IMPRES-Akkus – Kalibrierung erforderlich, aber nicht aktiviert

Status	Ladegerät- Display	LED-Anzeige
Ladegerät schaltet sich ein	IMPRES 2 CHARGER	Ca. 1 Sekunde lang grün 
Akku erkannt	IMPRES 2 AKKU oder IMPRES AKKU	Der Akku muss kalibriert werden, wurde aber innerhalb der letzten 30 Minuten vollständig geladen, aber die Kalibrierung ist im Ladegerät deaktiviert. Abwechselnd gelb/grün 
Störung	WARNUNG: NOT CHARGEABLE REMOVE & REINSERT	Rot blinkend 
Standby • Akku wartet auf Schnellladung. • Akku ist zu heiß, zu kalt oder Spannung zu niedrig. • Ladegerät ist zu heiß.	WARNUNG: HOT BATTERY WAITING TO CHARGE ODER COLD BATTERY WAITING TO CHARGE ODER VERY LOW BATTERY WAITING TO CHARGE ODER HOT CHARGER WAITING TO CHARGE	Gelb blinkend 

## Andere Akkus von Motorola Solutions

**Tabelle 11:** Ladeanzeigen für andere Motorola Solutions-Akkus

Status	Ladegerät-Display	LED-Anzeige
Ladegerät schaltet sich ein	IMPRES 2 CHARGER	Ca. 1 Sekunde lang grün 
Akku erkannt	MOTOROLA SOLUTIONS AKKU	Konstant rot 
Schnellladung	RAPID CHARGE	Konstant rot 
Zu 90 % oder mehr geladen	TRICKLE CHARGE	Grün blinkend 
Zu 95 % oder mehr geladen	CHARGE COMPLETE	Konstant grün 
Störung	WARNUNG: HOT CHARGEABLE REMOVE & REINSERT	Rot blinkend 
Standby <ul style="list-style-type: none"> <li>• Akku wartet auf Schnellladung.</li> <li>• Akku ist zu heiß, zu kalt oder Spannung zu niedrig.</li> <li>• Ladegerät ist zu heiß.</li> </ul>	WARNUNG: HOT BATTERY WAITING TO CHARGE ODER COLD BATTERY WAITING TO CHARGE ODER VERY LOW BATTERY WAITING TO CHARGE ODER HOT CHARGER WAITING TO CHARGE	Gelb blinkend 

## Unbekannter Akku

Das Ladegerät erkennt möglicherweise einige unbekannte Akkus nicht. Unbekannte Akkus deklarieren die Ladeparameter nicht so, dass das Ladegerät sie erkennen kann. Wird ein unbekannter Akku erkannt, zeigt das Ladegerät den Ladevorgang wie in Tabelle 12 zusammengefasst an.

**Tabelle 12:** Ladeanzeigen für unbekannte Akkus

Status	Ladegerät-Display	LED-Anzeige	
Ladegerät schaltet sich ein	IMPRES 2 CHARGER	Ca. 1 Sekunde lang grün	
Akku erkannt	UNKNOWN AKKU	Konstant rot	
Schnellladung	RAPID CHARGE	Konstant rot	
Fast geladen • Akkukapazität unbekannt	TRICKLE CHARGE	Grün blinkend	
Geladen • Akkukapazität unbekannt	CHARGE COMPLETE	Konstant grün	
Störung	WARNUNG: NOT CHARGEABLE REMOVE & REINSERT	Rot blinkend	
Standby • Akku wartet auf Schnellladung. • Akku ist zu heiß, zu kalt oder Spannung zu niedrig. • Ladegerät ist zu heiß.	WARNUNG: HOT BATTERY WAITING TO CHARGE ODER COLD BATTERY WAITING TO CHARGE ODER VERY LOW BATTERY WAITING TO CHARGE ODER HOT CHARGER WAITING TO CHARGE	Gelb blinkend	

## Langfristige Aufbewahrung von IMPRES 2- oder IMPRES-Akkus

Sie können separate Original-IMPRES 2- oder IMPRES-Akkus von Motorola Solutions (Lithium-Ionen oder Nickel) mithilfe eines IMPRES 2-Mehrfachladegeräts zur Wartung für die Langzeitaufbewahrung in einer geeigneten Lagereinrichtung vorbereiten. Andere Akkutypen sind fehlerhaft. Wenn der IMPRES 2-Akku mit einem Energiesparmodus ausgestattet ist, schaltet das Ladegerät den Akku nach Abschluss der Ladung für die Langzeitaufbewahrung in den Energiesparmodus.

Bereiten Sie nur IMPRES 2- oder IMPRES-Akkus für die Langzeitaufbewahrung vor. Entfernen Sie den Akku aus dem Funkgerät, bevor Sie ihn in das Ladegerät legen.

Bewahren Sie KEINE eigenständigen Akkus im Ladegerät auf. Wenn die Vorbereitung für die langfristige Aufbewahrung abgeschlossen ist, nehmen Sie den separaten Akku sofort aus dem Ladegerät.

Die Auswahl „Langzeitaufbewahrung“ ersetzt die Kalibrierung/Wiederaufarbeitung. Lithium-Akkus, die für eine langfristige Lagerung vorbereitet werden, entsprechen möglicherweise nicht den Bestimmungen für den Versand per Luftfracht.

**Tabelle 13:** Anzeigen für Langzeitlagerung eines IMPRES 2- oder IMPRES-Akkus – Akku muss kalibriert werden

Status	Ladegerät-Display	LED-Anzeige
Ladegerät schaltet sich ein	IMPRES 2 CHARGER	Ca. 1 Sekunde lang grün 
Akku erkannt	IMPRES 2 AKKU oder IMPRES AKKU	Akkukalibrierung erforderlich: Abwechselnd gelb und grün für 4 Sekunden 
Akku entlädt	STORAGE DISCHARGE xxxx % Rated Cap	Konstant gelb 
Schnellladung	STORAGE CHARGE xx % Rated Cap	Konstant rot 
Langfristige Aufbewahrung abgeschlossen	LONGTERM STORAGE xx % Rated Cap	Abwechselnd gelb/grün 



**Tabelle 13:** Anzeigen für Langzeitlagerung eines IMPRES 2- oder IMPRES-Akkus – Akku muss kalibriert werden (Forts.)

Status	Ladegerät-Display	LED-Anzeige
<p>Störung</p> <ul style="list-style-type: none"> <li>• Der Akku stellt keinen ordnungsgemäßen Kontakt mit dem Ladegerät her.</li> <li>• Der Akku ist kein IMPRES 2- oder IMPRES-Akku.</li> <li>• Ein unbekannter Fehler verhindert, dass der Akku entladen wird.</li> <li>• Der Ladevorgang wird abgeschlossen, bevor das Ziel „Langzeitlagerung“ erreicht wird.</li> <li>• Die Ladeschale ein spezieller Gerätetyp.</li> </ul>	<p>WARNUNG:  HOT CHARGEABLE  REMOVE &amp; REINSERT  ODER  WRONG BATT TYPE  CANNOT LT STORE  ODER  CANNOT DISCHARGE  FOR LT STORAGE  ODER  STORE INCOMPLETE  Low Capacity:yy%  ODER  FUNKGERÄT?  LADESCHALE  CANNOT LT STORE  ODER  LADESCHALE  CANNOT LT STORE</p>	<p>Rot blinkend</p> 
<p>Standby</p> <ul style="list-style-type: none"> <li>• Akku wartet auf Schnellladung.</li> <li>• Akku ist zu heiß, zu kalt oder Spannung zu niedrig.</li> <li>• Ladegerät ist zu heiß.</li> </ul>	<p>WARNUNG:  HOT BATTERY  WAITING TO CHARGE  ODER  COLD BATTERY  WAITING TO CHARGE  ODER  VERY LOW BATTERY  WAITING TO CHARGE  ODER  HOT CHARGER  WAITING TO CHARGE</p>	<p>Gelb blinkend</p> 

**Hinweis:**

- Die folgenden Meldungen werden in Softwareversion V1.05 eingeführt:
  - Cannot Discharge, for LT Storage
  - Store Incomplete, Low Capacity:yy%
  - Hot Charger, Waiting to Chrg
- Die folgenden Meldungen werden in Softwareversion V1.11.01 eingeführt:
  - Wrong Batt Type, Cannot LT Store
  - Radio Pocket, Cannot LT Store
  - Charging Pocket, Cannot LT Store

**Tabelle 14:** Anzeigen für Langzeitaufbewahrung eines IMPRES 2- oder IMPRES-Akkus – Kalibrierter Akku, muss bis Auswahl aufladen

Status	Ladegerät-Display	LED-Anzeige
Ladegerät schaltet sich ein	IMPRES 2 CHARGER	Ca. 1 Sekunde lang grün 
Akku erkannt	IMPRES 2 AKKU oder IMPRES AKKU	Konstant rot 
Schnellladung	STORAGE CHARGE xx % Rated Cap	Konstant rot 
Langfristige Aufbewahrung abgeschlossen	LONGTERM STORAGE xx % Rated Cap	Konstant grün 
<b>Störung</b> <ul style="list-style-type: none"> <li>• Der Akku stellt keinen ordnungsgemäßen Kontakt mit dem Ladegerät her.</li> <li>• Der Akku ist kein IMPRES 2- oder IMPRES-Akku.</li> <li>• Ein unbekannter Fehler verhindert, dass der Akku entladen wird.</li> <li>• Der Ladevorgang wird abgeschlossen, bevor das Ziel „Langzeitlagerung“ erreicht wird.</li> <li>• Die Ladeschale ein spezieller Gerätetyp.</li> </ul>	<b>WARNUNG:</b> NOT CHARGEABLE REMOVE & REINSERT ODER WRONG BATT TYPE CANNOT LT STORE ODER CANNOT DISCHARGE FOR LT STORAGE ODER STORE INCOMPLETE Low Capacity:yy% ODER FUNKGERÄT? LADESCHALE CANNOT LT STORE ODER LADESCHALE CANNOT LT STORE	Rot blinkend 
<b>Standby</b> <ul style="list-style-type: none"> <li>• Akku wartet auf Schnellladung.</li> <li>• Akku ist zu heiß, zu kalt oder Spannung zu niedrig.</li> <li>• Ladegerät ist zu heiß.</li> </ul>	<b>WARNUNG:</b> HOT BATTERY WAITING TO CHARGE ODER COLD BATTERY WAITING TO CHARGE ODER VERY LOW BATTERY WAITING TO CHARGE ODER HOT CHARGER WAITING TO CHARGE	Gelb blinkend 

**Tabelle 15:** Anzeigen für Langzeitaufbewahrung eines IMPRES 2- oder IMPRES-Akkus – Kalibrierter Akku, muss bis Auswahl entladen

Status	Ladegerät-Display	LED-Anzeige
Ladegerät schaltet sich ein	IMPRES 2 CHARGER	Ca. 1 Sekunde lang grün 
Akku erkannt	IMPRES 2 AKKU oder IMPRES AKKU	Konstant gelb 
Akku entlädt	STORAGE DISCHARGE xx % Rated Cap	Konstant gelb 
Langfristige Aufbewahrung abgeschlossen	LONGTERM STORAGE xx % Rated Cap	Konstant grün 
<b>Störung</b> <ul style="list-style-type: none"> <li>• Der Akku stellt keinen ordnungsgemäßen Kontakt mit dem Ladegerät her.</li> <li>• Der Akku ist kein IMPRES 2- oder IMPRES-Akku.</li> <li>• Ein unbekannter Fehler verhindert, dass der Akku entladen wird.</li> <li>• Der Ladevorgang wird abgeschlossen, bevor das Ziel „Langzeitlagerung“ erreicht wird.</li> <li>• Die Ladeschale ein spezieller Gerätetyp.</li> </ul>	<b>WARNUNG:</b> NOT CHARGEABLE REMOVE & REINSERT ODER WRONG BATT TYPE CANNOT LT STORE ODER CANNOT DISCHARGE FOR LT STORAGE ODER STORE INCOMPLETE Low Capacity:yy% ODER FUNKGERÄT? LADESCHALE CANNOT LT STORE ODER LADESCHALE CANNOT LT STORE	Rot blinkend 
<b>Standby</b> <ul style="list-style-type: none"> <li>• Akku wartet auf Schnellladung.</li> <li>• Akku ist zu heiß, zu kalt oder Spannung zu niedrig.</li> <li>• Ladegerät ist zu heiß.</li> </ul>	<b>WARNUNG:</b> HOT BATTERY WAITING TO CHARGE ODER COLD BATTERY WAITING TO CHARGE ODER VERY LOW BATTERY WAITING TO CHARGE ODER HOT CHARGER WAITING TO CHARGE	Gelb blinkend 

# Vorbereitung für den Versand von Lithium-Ionen-Akkus

Sie können separate IMPRES 2-, IMPRES- oder sonstige Original-Lithium-Ionen-Akkus von Motorola Solutions mithilfe eines IMPRES 2-Mehrfachladegeräts für den Versand per Luftfracht vorbereiten. Andere Akkutypen sind fehlerhaft. Wenn der IMPRES 2-Lithium-Ionen-Akku mit einem Energiesparmodus ausgestattet ist, versetzt das Ladegerät den Akku in den Energiesparzustand, wenn die Ladung „Ship Lithium“ abgeschlossen ist.

Bereiten Sie nur separate Lithium-Ionen-Akkus von Motorola Solutions für den Versand vor. Entfernen Sie den Akku aus dem Funkgerät, bevor Sie ihn in das Ladegerät legen.

Bewahren Sie KEINE eigenständigen Akkus im Ladegerät auf. Wenn die Vorbereitung für den Versand abgeschlossen ist, nehmen Sie den separaten Akku sofort aus dem Ladegerät.

Die Auswahl von „Lithium Shipment“ ersetzt die Kalibrierung/Wiederaufarbeitung.

## IMPRES 2- oder IMPRES-Akku

**Tabelle 16:** Statusanzeigen eines für den Versand vorbereiteten Lithium-Ionen-Akkus – IMPRES 2- oder IMPRES-Akku muss kalibriert werden

Status	Ladegerät-Display	LED-Anzeige
Ladegerät schaltet sich ein	IMPRES 2 CHARGER	Ca. 1 Sekunde lang grün 
Akku erkannt	IMPRES 2 AKKU oder IMPRES AKKU	Akkukalibrierung erforderlich: Abwechselnd gelb und grün für 4 Sekunden 
Akku entlädt	SHIP LI DISCHARGE xx % Rated Cap	Konstant gelb 
Schnellladung	SHIP LI CHARGE xx % Rated Cap	Konstant rot 
Versand von Lithium-Ionen-Akku abgeschlossen	LI READY TO SHIP xx % Rated Cap	Abwechselnd gelb/grün 

**Tabelle 16:** Statusanzeigen eines für den Versand vorbereiteten Lithium-Ionen-Akkus – IMPRES 2- oder IMPRES-Akku muss kalibriert werden (Forts.)

Status	Ladegerät-Display	LED-Anzeige
<p>Störung</p> <ul style="list-style-type: none"> <li>• Der Akku stellt keinen ordnungsgemäßen Kontakt mit dem Ladegerät her.</li> <li>• Akku ist unbekannt oder Nickel.</li> <li>• Ein unbekannter Fehler verhindert, dass der Akku entladen wird.</li> <li>• Der Ladevorgang wird abgeschlossen, bevor das Ziel „Ship Lithium“ erreicht wird.</li> <li>• Die Ladeschale ein spezieller Gerätetyp.</li> </ul>	<p>WARNUNG:            NOT CHARGEABLE            REMOVE &amp; REINSERT            ODER            WRONG BATT TYPE            CANNOT SHIP LI            ODER            CANNOT DISCHARGE            FOR LI SHIPMENT            ODER            SHIP INCOMPLETE            Low Capacity:yy%            ODER            FUNKGERÄT?            LADESCHALE            CANNOT SHIP LI            ODER            LADESCHALE            CANNOT SHIP LI</p>	<p>Rot blinkend</p> 
<p>Standby</p> <ul style="list-style-type: none"> <li>• Akku wartet auf Schnellladung.</li> <li>• Akku ist zu heiß, zu kalt oder Spannung zu niedrig.</li> <li>• Ladegerät ist zu heiß.</li> </ul>	<p>WARNUNG:            HOT BATTERY            WAITING TO CHARGE            ODER            COLD BATTERY            WAITING TO CHARGE            ODER            VERY LOW BATTERY            WAITING TO CHARGE            ODER            HOT CHARGER            WAITING TO CHARGE</p>	<p>Gelb blinkend</p> 

**Hinweis:**

- Die folgenden Meldungen werden in Softwareversion V1.05 eingeführt:
  - Ship LI Discharge, xxx% Rated Capacity
  - Ship LI Charge, xxx% Rated Capacity
  - LI Ready to Ship, xx% Rated Capacity
  - Cannot Discharge, for LI Shipment
  - Ship Incomplete, Low Capacity:yy%
- Die folgenden Meldungen werden in Softwareversion V1.11.01 eingeführt:
  - Wrong Batt Type, Cannot Ship LI
  - Radio Pocket, Cannot Ship LI
  - Charging Pocket, Cannot Ship LI

**Tabelle 17:** Statusanzeigen eines für den Versand vorbereiteten Lithium-Ionen-Akkus – IMPRES 2- oder IMPRES-Akku kalibriert, muss aufladen

Status	Ladegerät-Display	LED-Anzeige
Ladegerät schaltet sich ein	IMPRES 2 CHARGER	Ca. 1 Sekunde lang grün 
Akku erkannt	IMPRES 2 AKKU oder IMPRES AKKU	Konstant rot 
Schnellladung	SHIP LI CHARGE xx % Rated Cap	Konstant rot 
Versand von Lithium-Ionen-Akku abgeschlossen	LI READY TO SHIP xx % Rated Cap	Konstant grün 
<p>Störung</p> <ul style="list-style-type: none"> <li>• Der Akku stellt keinen ordnungsgemäßen Kontakt mit dem Ladegerät her.</li> <li>• Akku ist unbekannt oder Nickel.</li> <li>• Ein unbekannter Fehler verhindert, dass der Akku entladen wird.</li> <li>• Der Ladevorgang wird abgeschlossen, bevor das Ziel „Ship Lithium“ erreicht wird.</li> <li>• Die Ladeschale ein spezieller Gerätetyp.</li> </ul>	<p>WARNUNG: NOT CHARGEABLE REMOVE &amp; REINSERT ODER WRONG BATT TYPE CANNOT SHIP LI ODER CANNOT DISCHARGE FOR LI SHIPMENT ODER SHIP INCOMPLETE Low Capacity:yy% ODER FUNKGERÄT? LADESCHALE CANNOT SHIP LI ODER LADESCHALE CANNOT SHIP LI</p>	<p>Rot blinkend </p>
<p>Standby</p> <ul style="list-style-type: none"> <li>• Akku wartet auf Schnellladung.</li> <li>• Akku ist zu heiß, zu kalt oder Spannung zu niedrig.</li> <li>• Ladegerät ist zu heiß.</li> </ul>	<p>WARNUNG: HOT BATTERY WAITING TO CHARGE ODER COLD BATTERY WAITING TO CHARGE ODER VERY LOW BATTERY WAITING TO CHARGE ODER HOT CHARGER WAITING TO CHARGE</p>	<p>Gelb blinkend </p>

**Tabelle 18:** Statusanzeigen eines für den Versand vorbereiteten Lithium-Ionen-Akkus – IMPRES 2- oder IMPRES-Akku kalibriert, muss entladen

Status	Ladegerät-Display	LED-Anzeige	
Ladegerät schaltet sich ein	IMPRES 2 CHARGER	Ca. 1 Sekunde lang grün	
Akku erkannt	IMPRES 2 AKKU oder IMPRES AKKU	Konstant gelb	
Akku entlädt	SHIP LI DISCHARGE xx % Rated Cap	Konstant gelb	
Versand von Lithium-Ionen-Akku abgeschlossen	LI READY TO SHIP xx % Rated Cap	Konstant grün	
<b>Störung</b> <ul style="list-style-type: none"> <li>• Der Akku stellt keinen ordnungsgemäßen Kontakt mit dem Ladegerät her.</li> <li>• Akku ist unbekannt oder Nickel.</li> <li>• Ein unbekannter Fehler verhindert, dass der Akku entladen wird.</li> <li>• Der Ladevorgang wird abgeschlossen, bevor das Ziel „Ship Lithium“ erreicht wird.</li> <li>• Die Ladeschale ein spezieller Gerätetyp.</li> </ul>	<b>WARNUNG:</b> NOT CHARGEABLE REMOVE & REINSERT ODER WRONG BATT TYPE CANNOT SHIP LI ODER CANNOT DISCHARGE FOR LI SHIPMENT ODER SHIP INCOMPLETE Low Capacity:yy% ODER FUNKGERÄT? LADESCHALE CANNOT SHIP LI ODER LADESCHALE CANNOT SHIP LI	Rot blinkend	
<b>Standby</b> <ul style="list-style-type: none"> <li>• Akku wartet auf Schnellladung.</li> <li>• Akku ist zu heiß, zu kalt oder Spannung zu niedrig.</li> <li>• Ladegerät ist zu heiß.</li> </ul>	<b>WARNUNG:</b> HOT BATTERY WAITING TO CHARGE ODER COLD BATTERY WAITING TO CHARGE ODER VERY LOW BATTERY WAITING TO CHARGE ODER HOT CHARGER WAITING TO CHARGE	Gelb blinkend	

## Andere Akkus von Motorola Solutions

**Tabelle 19:** Statusanzeigen eines für den Versand vorbereiteten Lithium-Ionen-Akkus – Anderer Akku von Motorola Solutions

Status	Ladegerät-Display	LED-Anzeige
Ladegerät schaltet sich ein	IMPRES 2 CHARGER	Ca. 1 Sekunde lang grün 
Akku erkannt	MOTOROLA SOLUTIONS AKKU	Konstant gelb 
Akku entlädt	SHIP LI DISCHARGE xx % Rated Cap	Konstant gelb 
Schnellladung	SHIP LI CHARGE xx % Rated Cap	Konstant rot 
Versand von Lithium-Ionen-Akku abgeschlossen	LI READY TO SHIP xx % Rated Cap	Konstant grün 
<b>Störung</b> <ul style="list-style-type: none"> <li>• Der Akku stellt keinen ordnungsgemäßen Kontakt mit dem Ladegerät her.</li> <li>• Akku ist unbekannt oder Nickel.</li> <li>• Ein unbekannter Fehler verhindert, dass der Akku entladen wird.</li> <li>• Der Ladevorgang wird abgeschlossen, bevor das Ziel „Ship Lithium“ erreicht wird.</li> <li>• Die Ladeschale ein spezieller Gerätetyp.</li> </ul>	<b>WARNUNG:</b> NOT CHARGEABLE REMOVE & REINSERT ODER WRONG BATT TYPE CANNOT SHIP LI ODER CANNOT DISCHARGE FOR LI SHIPMENT ODER SHIP INCOMPLETE Low Capacity:yy% ODER FUNKGERÄT? LADESCHALE CANNOT SHIP LI ODER LADESCHALE CANNOT SHIP LI	Rot blinkend 
<b>Standby</b> <ul style="list-style-type: none"> <li>• Akku wartet auf Schnellladung.</li> <li>• Akku ist zu heiß, zu kalt oder Spannung zu niedrig.</li> <li>• Ladegerät ist zu heiß.</li> </ul>	<b>WARNUNG:</b> HOT BATTERY WAITING TO CHARGE ODER COLD BATTERY WAITING TO CHARGE ODER VERY LOW BATTERY WAITING TO CHARGE ODER HOT CHARGER WAITING TO CHARGE	Gelb blinkend 



## Einrichtungsmenü des Ladegeräts



Ladegerät erst einrichten, wenn alle Ladeschalen geleert wurden.

Die Tastatur des Ladegeräts befindet sich unter dem Display von Ladeschale 1.

Drücken Sie gleichzeitig die rechte und linke Pfeiltaste, und halten Sie sie länger gedrückt als die Eingabezeit für eine Auswahl (3 Sekunden, Standard), um in das Menü des Ladegeräts zu gelangen.

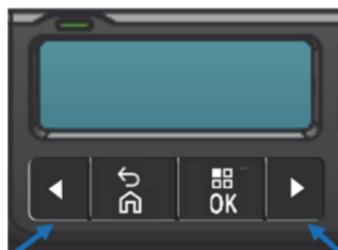

Nach links

Nach rechts

**Abbildung 4:** Menüanzeigetasten für den Zugriff auf den  
Einrichtungsmodus

### Hauptmenü

Nach dem Aufrufen der Ladegeräteinrichtung wird die folgende Meldung angezeigt:

```
Press OK to entr  
SETUP MENU
```

Drücken Sie OK, um das verfügbare Einrichtungsmenü des Ladegeräts zu öffnen.



Abbildung 5: Einrichtungsmenü des Ladegeräts

## Einrichtungsmenüauswahl des Ladegeräts

In jeder Auswahl des Einrichtungsmenü:

- Drücken Sie die rechte Pfeiltaste, um durch die Menüauswahl zu navigieren.
- Um durch die Menüauswahl in umgekehrter Reihenfolge zu navigieren, drücken Sie die linke Pfeiltaste.
- Um das ausgewählte Menü aufzurufen oder die gewünschte Option auszuwählen, drücken Sie OK.

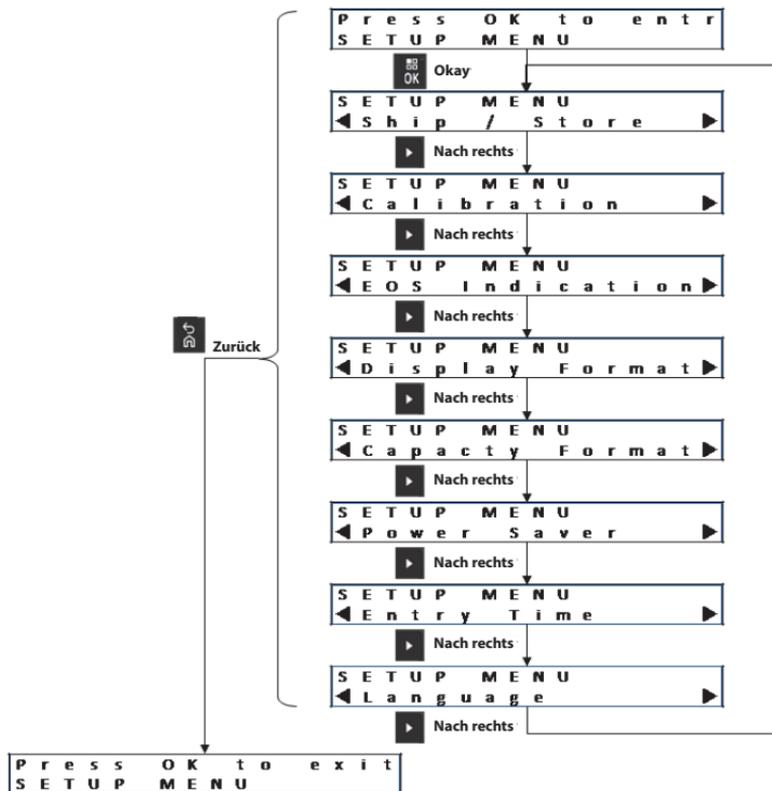
**Hinweis:** Die aktuell ausgewählte Option ist mit einem Häkchen markiert.

In V1.11.01 eingeführt. Drücken Sie OK, um die nächste Ladeschale auf dem Display der Ladeschale 1 anzuzeigen.

- Um das ausgewählte Menü zu verlassen, drücken Sie die Back-Taste, und bestätigen Sie das Beenden mit OK.

Wenn 10 Minuten lang keine Taste gedrückt wird, verlässt das Ladegerät das Einrichtungsmenü und kehrt in den Normalzustand zurück.

Die Auswahl im Einstellungsmenü wird im nichtflüchtigen Speicher gespeichert. Ein-/ und Ausschalten verändern die Auswahl nicht.

## **Versand- oder Lagerungsmenü**

Es gibt vier Versand-/Lagerungsoptionen

- Deaktiviert
- Ship Lithium-Ion
- Langfristige Lagerung
- Langfristige Lagerung bei 75 % der Nennkapazität

Die Optionen Versand von Lithium-Ionen-Akku, langfristige Lagerung und langfristige Lagerung bei 75 % lösen die Kalibrierungseinstellung ab.



## Langfristige Lagerung

Bei Langzeitaufbewahrung wird der Ladestatus des IMPRES 2- oder IMPRES-Akkus auf einen Wert eingestellt, der für die Langzeitaufbewahrung des Akkus geeignet ist. Im Allgemeinen ist der bevorzugte Ladestatus deutlich geringer als die volle Ladung. Die Auswahl  $xx\%$  ist ein Wert, der in IMPRES 2- oder IMPRES-Akkus programmiert wird oder standardmäßig 50 % der Nennkapazität beträgt. Die Langzeitaufbewahrung bei 75 % Nennkapazität ist für verschiedene Szenarien verfügbar, in denen der gelagerte Akku mit einem höheren Ladestatus aufbewahrt werden soll, sodass er bei Bedarf schneller aufgeladen ist oder eine längere Lagerungsdauer ermöglicht wird.

Einige IMPRES 2- oder IMPRES-Akkus können vollständig entladen sein, bevor sie zur Auswahl für die Langzeitaufbewahrung geladen werden. Zu diesen Akkus gehören IMPRES 2- oder IMPRES-Akkus, die noch nicht kalibriert wurden oder neu kalibriert werden müssen.

Die Langzeitaufbewahrung gilt nur für IMPRES 2- oder IMPRES-Akkus. Andere Akkus (z. B. unbekannte oder Nicht-IMPRES- oder Gehäuseakkus von Motorola Solutions) sind nicht zulässig.

### IMPRES 2-Akkus mit Energiesparmodus

Einige IMPRES 2-Akkus sind mit einem Energiesparmodus ausgestattet. Der Energiesparmodus wird verwendet, um die Zeit bis zum nächsten Aufladen des Akkus zu verlängern. Nach Abschluss des Ladevorgangs „Ship Lithium“ oder „Long-Term Storage“ versetzt das Ladegerät diese Akkus in den Energiesparmodus.

Wenn Sie einen IMPRES 2-Akku im Energiesparmodus in ein Ladegerät einlegen, wird er wieder in den normalen Modus versetzt. Wenn der Akku für den Versand vorbereitet wird, wird er durch Einsetzen in ein Ladegerät, bei dem „Ship Lithium“ eingestellt ist, wieder in den Energiesparmodus versetzt. Wenn der Akku für die Langzeitaufbewahrung vorbereitet wird, wird er durch Einsetzen in ein Ladegerät, bei dem „Long-Term Storage“ eingestellt ist, wieder in den Energiesparmodus versetzt.

## Kalibrierungseinstellung

Mit den Einstellungsoptionen für die Kalibrierung aktivieren und deaktivieren Sie die Entladephase der Kalibrierung/Wiederaufarbeitung. Die Entladephase geht der vollständigen Ladung voraus und ist für eine erfolgreiche Kalibrierung/Wiederaufarbeitung erforderlich. Diese Funktion ist hilfreich, wenn das Ladegerät an einem Ort eingesetzt wird, wo der Akku so schnell wie möglich einsatzbereit sein soll. In diesen Situationen kann es unpraktisch sein, auf die Entladung des Akkus zu warten.

Wenn ein IMPRES 2- oder IMPRES-Akku kalibriert werden muss und beim Einsetzen in das Ladegerät bereits entladen ist, kann das Ladegerät den Ladungsabschluss als Akkukalibrierung verwenden.



Abbildung 7: Kalibrierungseinstellung

## LED-Anzeigemenü der Akkulebensdauer

Auch wenn der IMPRES 2- oder IMPRES-Akku sich dem Ende seiner Lebensdauer nähert, kann die Ladekapazität des Akkus möglicherweise noch mehr als ausreichend für den leichteren Einsatz sein. Daher kann es sinnvoll sein, die LED-Anzeige für die Akkulebensdauer (**abwechselnd rot/grün**) zu deaktivieren.

Bei APX NEXT XN-Akkus wird mit der Deaktivierung dieser Anzeige auch die Anzeige deaktiviert, wenn der Akku einer kumulativen Übertemperatur ausgesetzt wird.

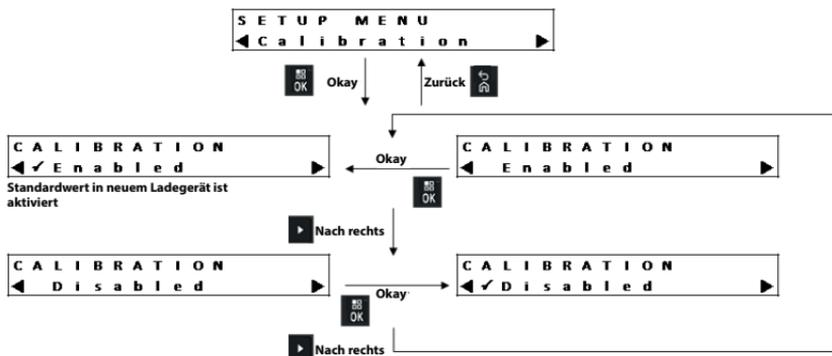

Abbildung 8: LED-Anzeigemenü der Akkulebensdauer

## Menü des Displayformats

Es gibt vier Optionen für das Displayformat:

- Normale Ausrichtung „Normal“ (Ladegerät steht auf einer horizontalen Fläche).
- Umgedrehte Ausrichtung „Inverted“ (Ladegerät hängt an der Wand).
- Nur Warnmeldungen. Andere Meldungen werden nicht angezeigt. Dies gilt für normale und umgedrehte Bildschirmausrichtungen. Warnmeldungen werden in Tabelle 6 bis Tabelle 12 identifiziert.
- Das Display ist während des normalen Betriebs ausgeschaltet. Das Display ist immer im Einrichtungs- und Analysemodus aktiviert.

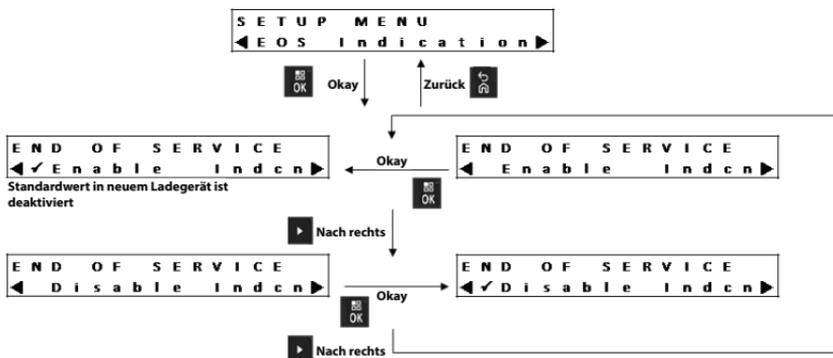

Abbildung 9: Menü des Displayformats



## Menü des Kapazitätsformats

Die Akkukapazität wird in einem von mehreren verfügbaren Formaten angezeigt. Wenn die Akkukapazität als Prozentsatz angezeigt wird, bezieht sich der Prozentsatz entweder auf die potenzielle Kapazität (volle Ladung) oder die Nennkapazität. In der Regel zeigen IMPRES-Akkus den Prozentsatz der Akkukapazität an, der auf die potenzielle Kapazität bezogen ist.

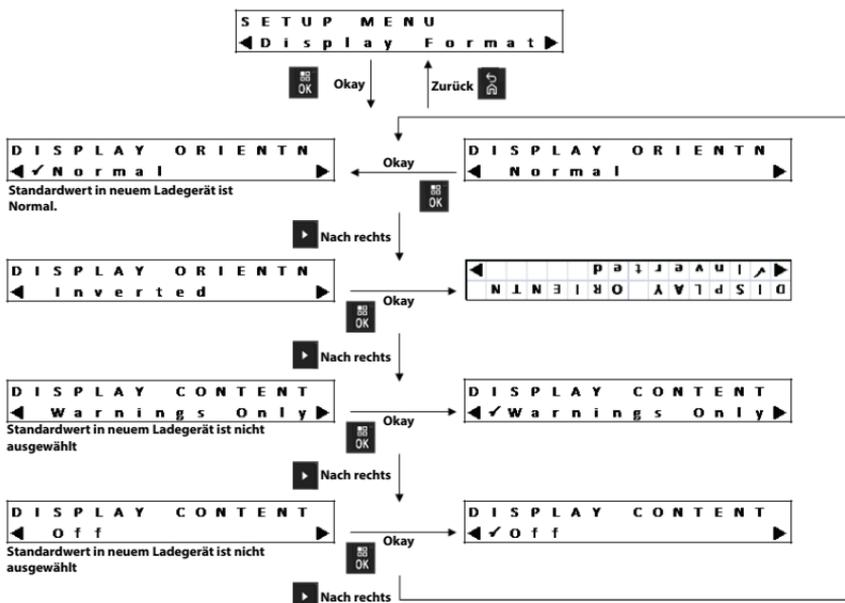

Abbildung 10: Menü des Kapazitätsformats

**Tabelle 20:** Anzeigeoptionen für Akkukapazität

Darstellung	Beschreibung
xxx0 mAh	Aktueller Ladezustand (State of Charge) in Milliampere-Stunden.
yyy %	Aktueller Ladezustand im Verhältnis zur potenziellen Kapazität oder Nennkapazität in Prozent. In Bezug auf die potenzielle Kapazität beträgt der Höchstwert 100 %. In Bezug auf die Nennkapazität kann der Maximalwert größer als 100 % sein, insbesondere bei einem neuen Akku.
%STRICH	Das Äquivalent von yyy % auf einem Strichdiagramm mit 8 Segmenten dargestellt.

## Menü Energiesparmodus

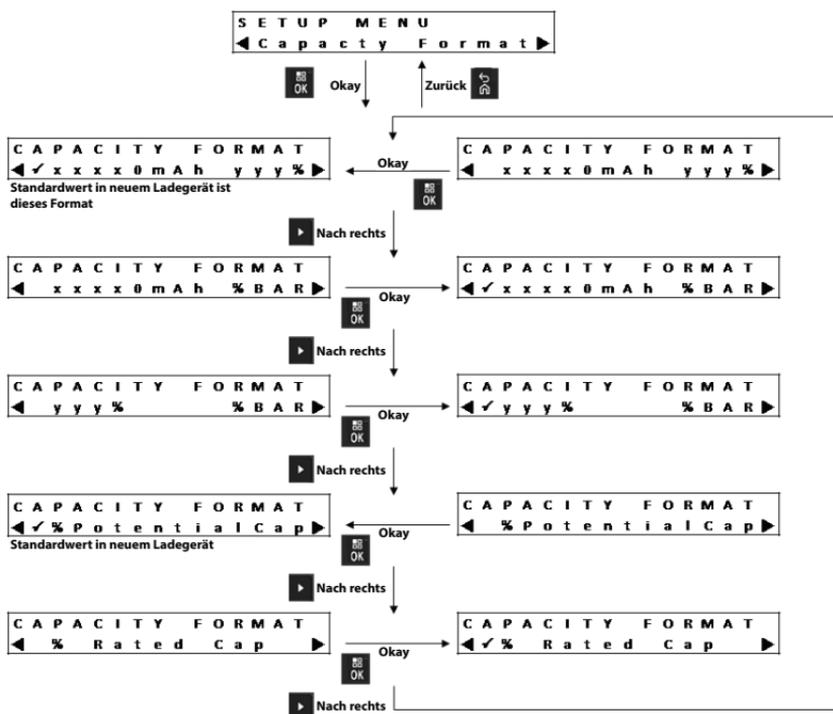
Um bestimmte behördliche Anforderungen zum geringen Stromverbrauch zu erfüllen, können im Energiesparmodus alle Schalen des Ladegeräts außer Schale 1 ausgeschaltet werden, wenn in diesen Schalen für einen gewissen Zeitraum keine Aktivität stattfindet. Beispiele für Aktivität:

- Funkgerät- oder Akkuladung
- Akkukalibrierung/-wiederaufarbeitung
- Vorbereiten originaler Lithium-Ionen-Akkus von Motorola Solutions für den Versand
- Vorbereitung von IMPRES 2- oder IMPRES-Akkus für die Langzeitaufbewahrung.
- Einrichtungs- oder Analysemodus des Ladegeräts.
- Ladegerät-Neuprogrammierung.
- Kommunikation mit dem IMPRES Battery Fleet Management-System.
- Beliebige blinkende LED-Anzeige.

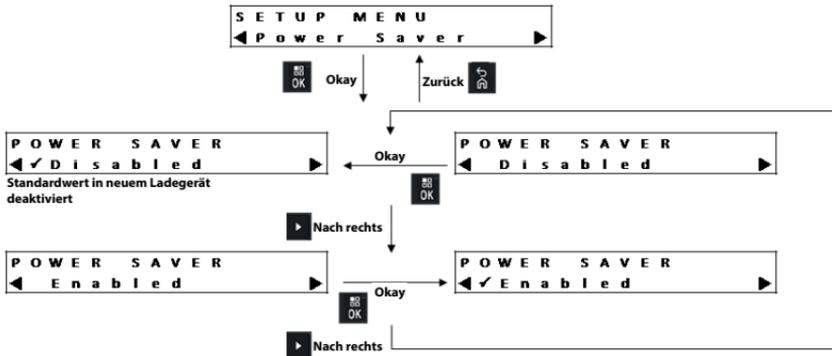

**Abbildung 11:** Menü Energiesparmodus

Schale 1 bleibt an, ist aber möglicherweise im Schlafmodus. Drücken Sie eine beliebige Taste auf der Tastatur, um die anderen Schalen einzuschalten. Die Schalen können erst dann auf eingesetzte Funkgeräte oder Akkus reagieren, wenn sie eingeschaltet wurden.

### Menü „Entry Time“

Die „Entry Time“ ist die Zeit, über die eine Taste gedrückt gehalten werden muss, um den Einrichtungs- oder Ladegerätanalysemodus zu starten.



Abbildung 12: Menü „Entry Time“

## Menü Sprache

Das Display des Ladegeräts unterstützt derzeit eine Sprache:  
US-amerikanisches Englisch.

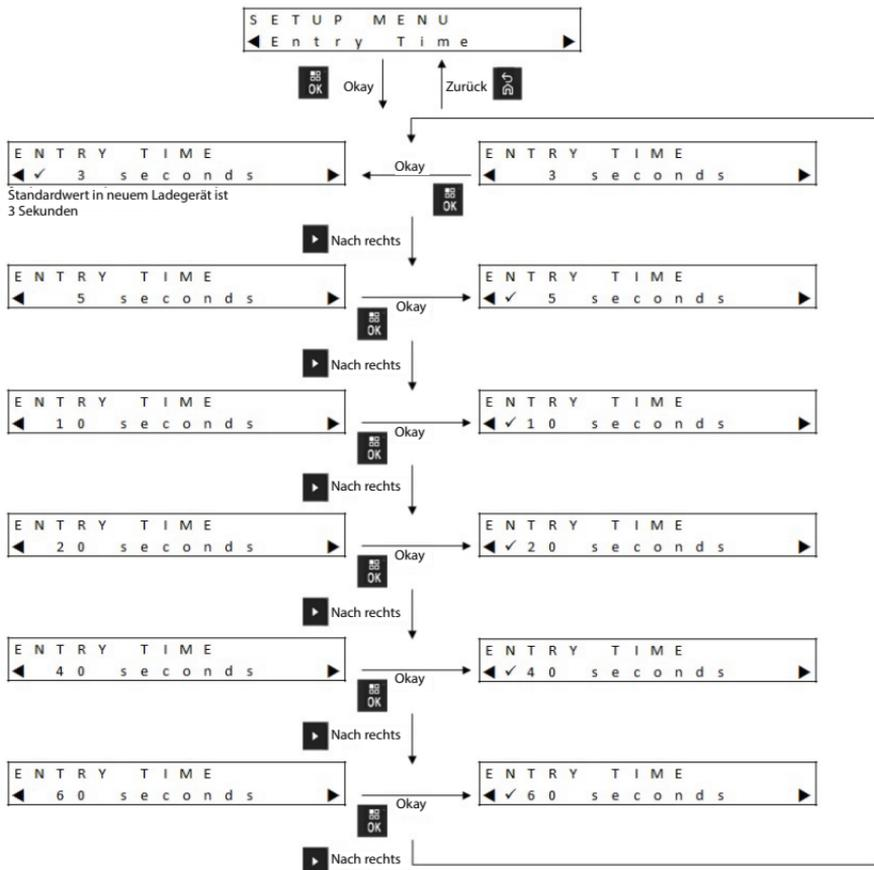

Abbildung 13: Menü Sprache

## Analysemodus (Analyzer Mode)

Die Tastatur des Ladegeräts befindet sich unter dem Display von Ladeschale 1.

Um in den Analyzer Mode zu wechseln, halten Sie die OK-Taste länger gedrückt als die Eingabezeit für eine Auswahl (3 Sekunden, Standard).

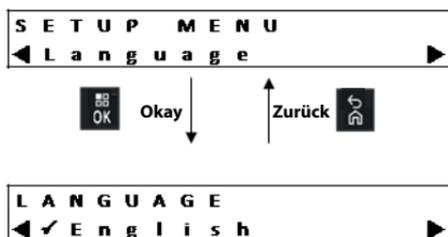

Abbildung 14: Menüanzeigetaste für den Wechsel in den Analyzer Mode

Nach dem Aufrufen des Analyzer Mode wird die folgende Meldung angezeigt:

```
Press OK to entr  
SETUP MENU
```

Drücken Sie OK, um die verfügbaren Akkuinformationen anzuzeigen:

## Version V1.0 – Analyzer Mode

In Softwareversion V1.0 ist der Analyzer Mode nur für Ladeschale 1 verfügbar. Analyseinformationen zu Ladeschale 1 und deren Inhalt werden auf dem Display von Ladeschale 1 angezeigt. Wenn 10 Minuten lang keine Taste gedrückt wird, verlässt das Ladegerät den Analyzer Mode und kehrt in den Normalzustand zurück.



Abbildung 15: Version V1.0 – Analyzer Mode – Menü

## Version V1.05 – Analyzer Mode

Der Analyzer Mode wird durch die Veröffentlichung der Softwareversion V1.05 verbessert. Bei Ladegeräten mit Display in jeder Ladeschale werden die Analyseinformationen auf dem Display neben der entsprechenden Ladeschale angezeigt. Beim Durchsuchen der Analyseinformationen für Ladeschale 1 werden die Analyseinformationen, die für die angrenzende Ladeschale verfügbar sind, auf anderen Displays durchsucht.

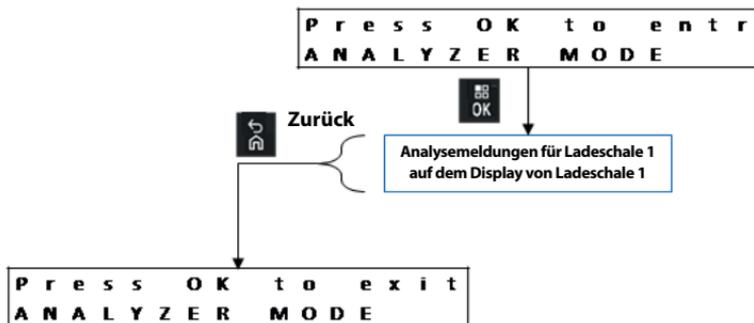

Abbildung 16: Version V1.05 – Analyzer Mode – Menü

## Version V1.11.01 – Analyzer Mode

Der Analyzer Mode wird durch die Veröffentlichung der Softwareversion V1.11.01 erneut verbessert. Bei Ladegeräten mit Display nur auf Ladeschale 1 wird das Menüdisplay von Ladeschale 1 verwendet, um Informationen für andere Ladeschalen anzuzeigen. Die Verbesserung der Version V1.05 bleibt erhalten.

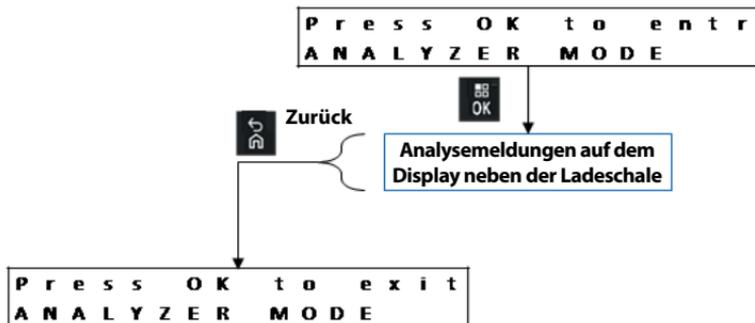

Abbildung 17: Version V1.11.01 – Analyzer Mode – Menü

## Austauschen von Akkus in einer Ladeschale

Wenn ein Akku entfernt wird und dann derselbe oder ein anderer Akku in dieselbe Ladeschale eingelegt wird, entspricht der angezeigte Parameter für den zweiten Akku dem Parameter, der für den ersten Akku angezeigt wurde.

Beispiel: `Battery IMPRES Cycles` wird für einen IMPRES 2- oder IMPRES-Akku angezeigt. Dieser Akku wird aus der Ladeschale entnommen. Ein anderer IMPRES 2- oder IMPRES-Akku wird in dieselbe Ladeschale eingesetzt. Der erste angezeigte Parameter für den zweiten Akku zeigt `Battery IMPRES Cycles. an`.

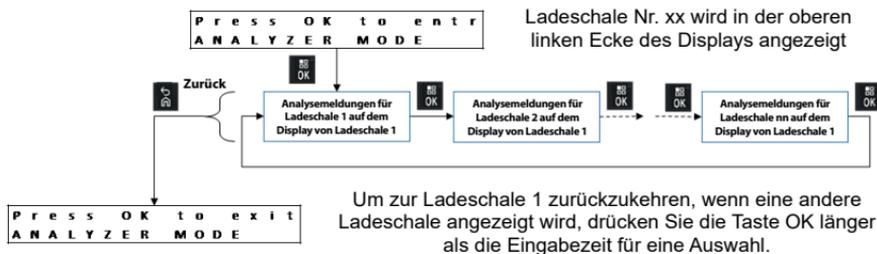
Beim zweiten Akku wird der Parameter für den ersten Akku jedoch möglicherweise nicht angezeigt. In diesem Fall wird die Identifizierungsmeldung für den zweiten Akku angezeigt.



# IMPRES 2-Akku

## Neben Ladeschale anzeigen



Abbildung 18: IMPRES 2-Akku – Analyzer-Mode-Menü für Display neben Ladeschale

# Ladeschale 1 zeigt andere Ladeschale an

Ladeschale Nr. xx wird in der oberen linken Ecke des Displays angezeigt

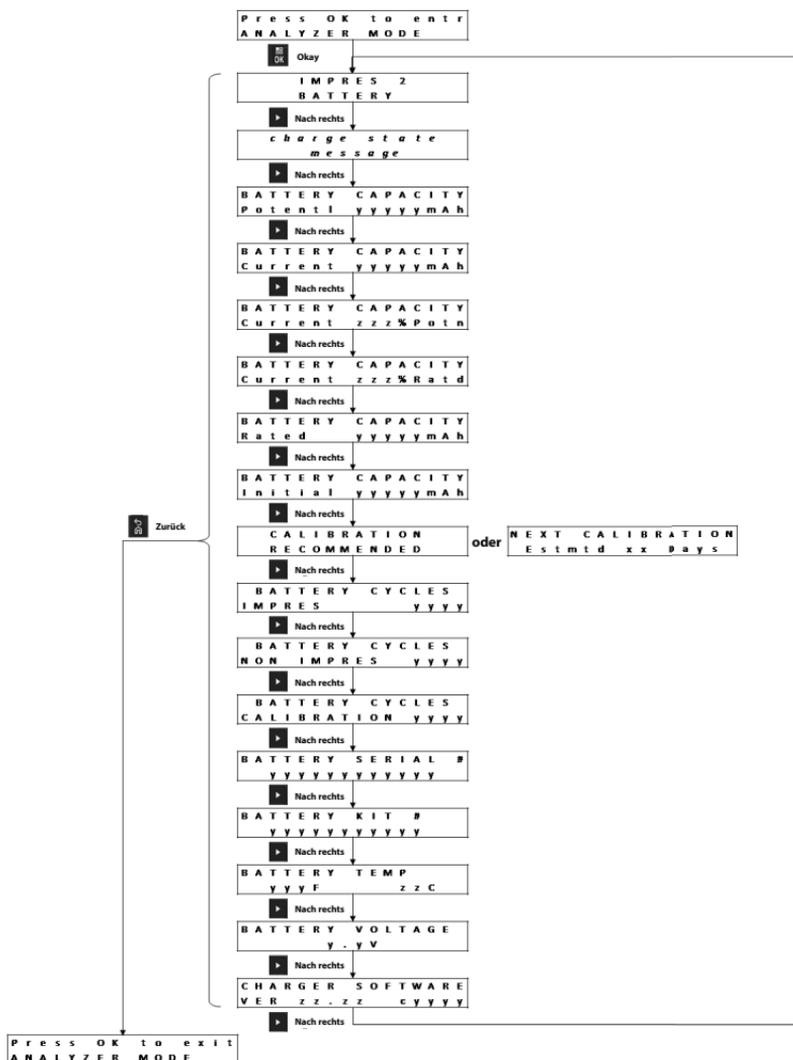

Abbildung 19: IMPRES 2-Akku – Analyzer-Mode-Menü für andere Ladeschale (nicht Ladeschale 1)

Deutsch

# IMPRES-Akku

## Neben Ladeschale anzeigen

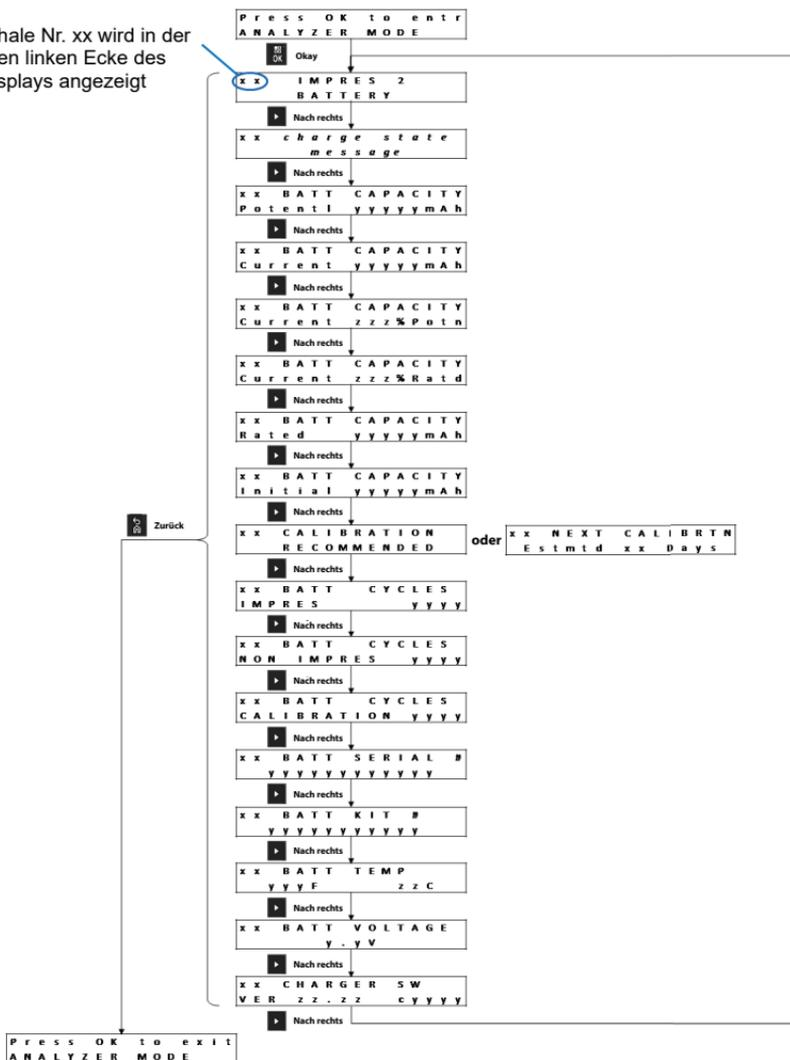

Abbildung 20: IMPRES-Akku – Analyzer-Mode-Menü für Display neben Ladeschale

# Ladeschale 1 zeigt andere Ladeschale an

Ladeschale Nr. xx wird in der oberen linken Ecke des Displays angezeigt

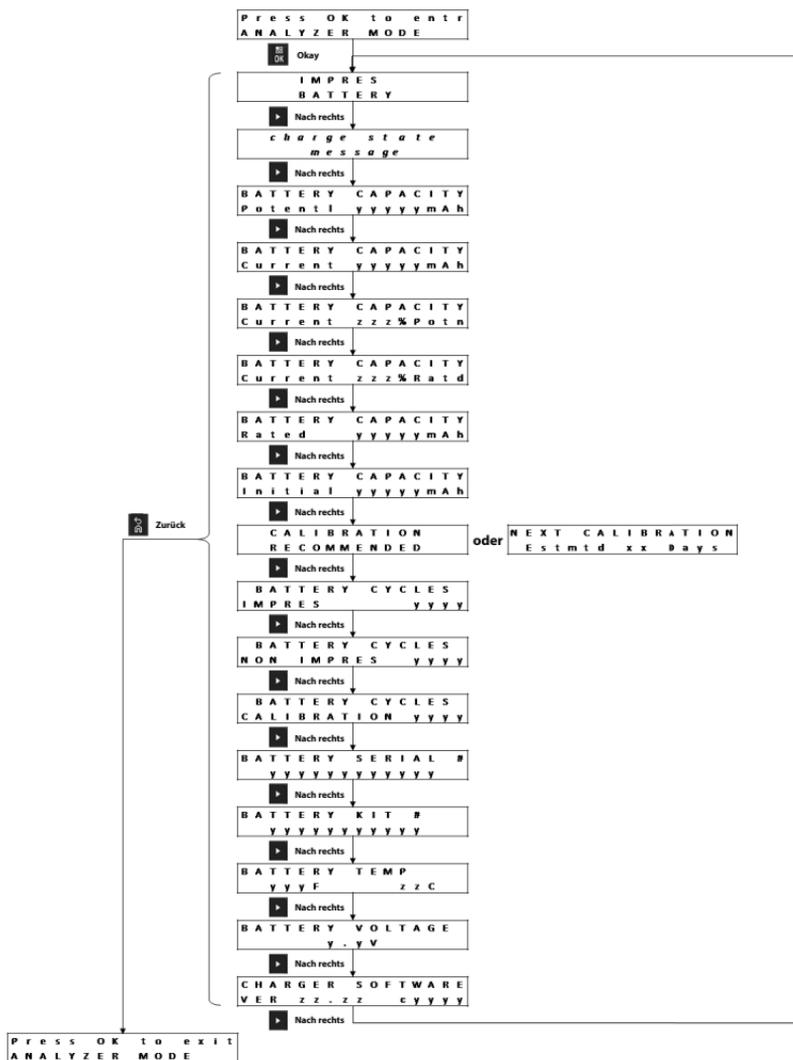

Abbildung 21: IMPRES-Akku – Analyzer-Mode-Menü für andere Ladeschale (nicht Ladeschale 1)

Deutsch

# Anderer Akku von Motorola Solutions

## Neben Ladeschale anzeigen

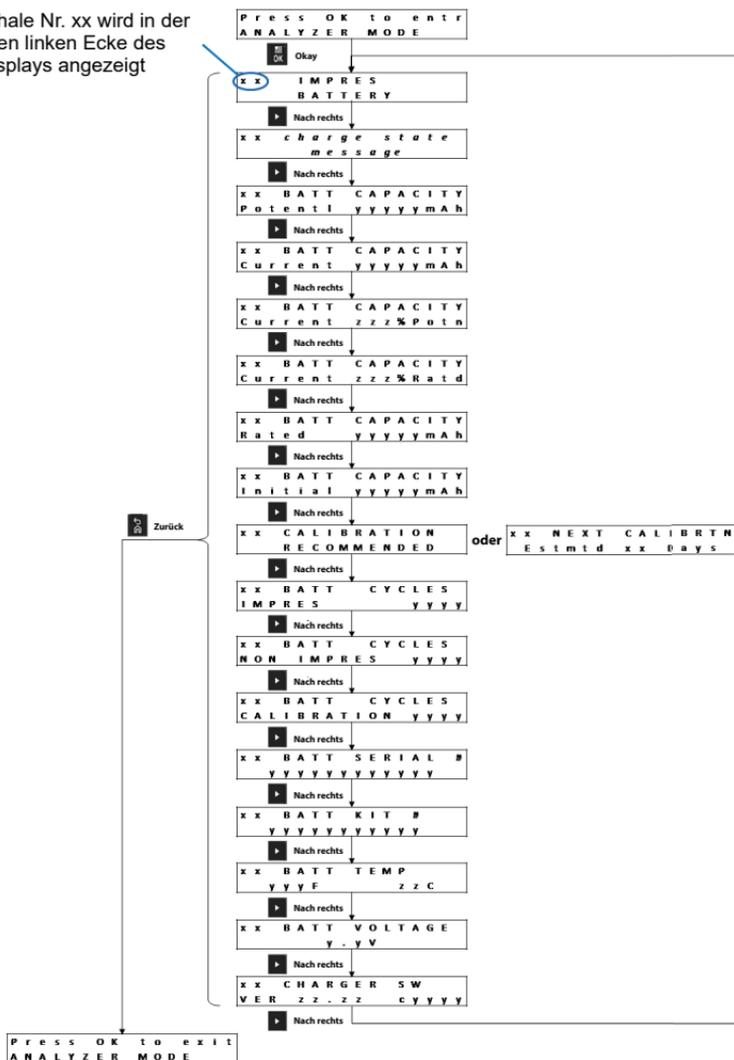

Abbildung 22: Anderer Akku von Motorola Solutions – Analyzer-Mode-Menü für Display neben Ladeschale

## Ladeschale 1 zeigt andere Ladeschale an

Ladeschale Nr. xx wird in der oberen linken Ecke des Displays angezeigt

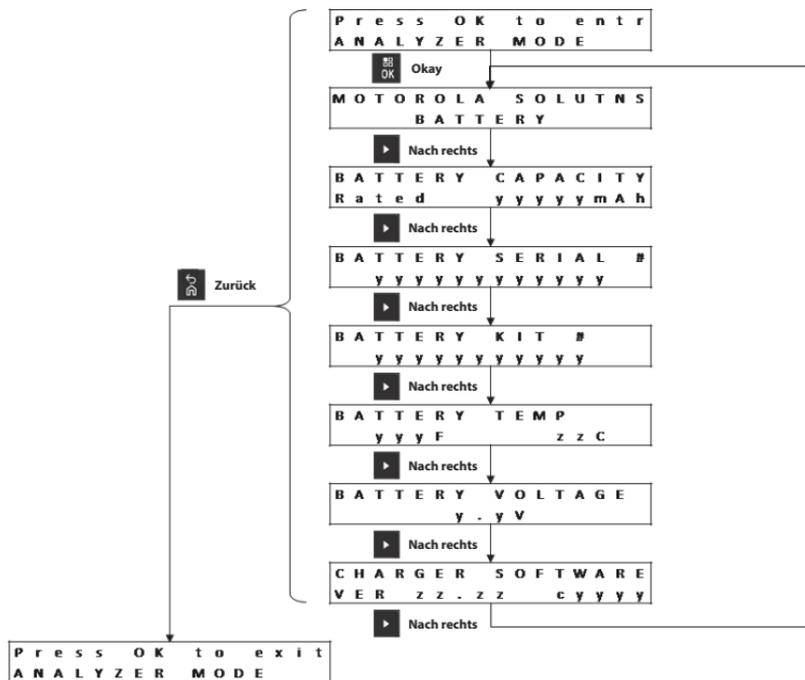
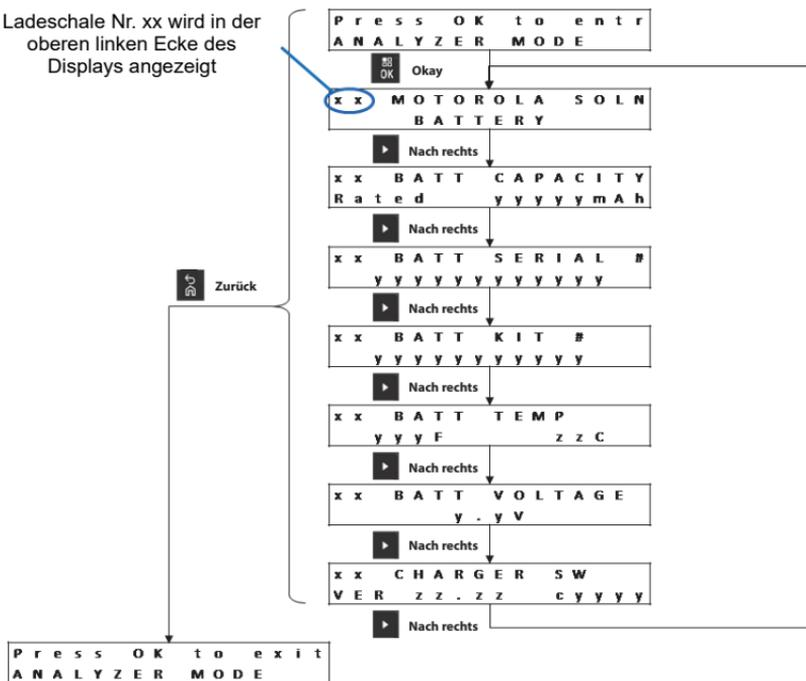

**Abbildung 23:** Anderer Akku von Motorola Solutions – Analyzer-Mode-Menü für andere Ladeschale (nicht Ladeschale 1)

# Unbekannter Akku

## Neben Ladeschale anzeigen



Abbildung 24: Unbekannter Akku – Analyzer-Mode-Menü für Display neben Ladeschale

## Ladeschale 1 zeigt andere Ladeschale an

Ladeschale Nr. xx wird in der oberen linken Ecke des Displays angezeigt

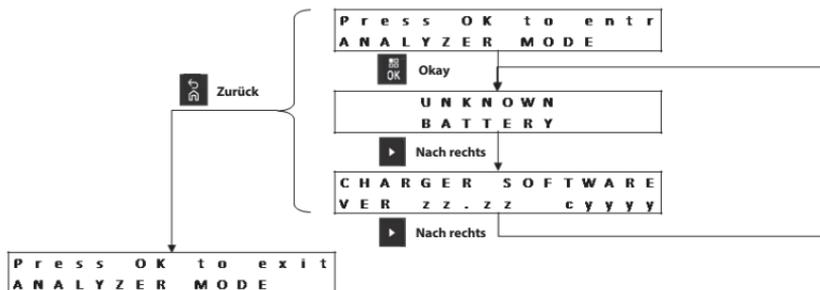

Abbildung 25: Unbekannter Akku – Analyzer-Mode-Menü für andere Ladeschale (nicht Ladeschale 1)

## Leere Schale

### Neben Ladeschale anzeigen

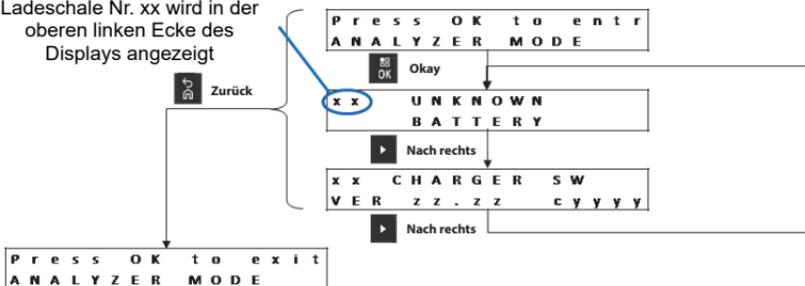
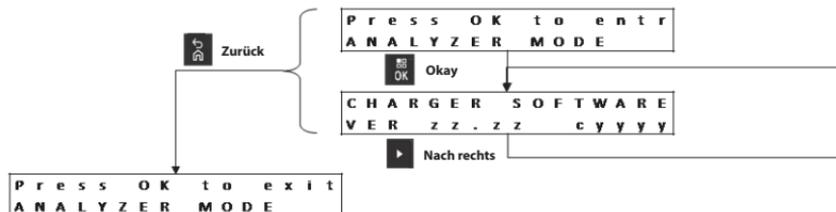

**Abbildung 26:** Analyzer-Mode-Menü für leere Ladeschale neben Display

### Ladeschale 1 zeigt andere Ladeschale an

Ladeschale Nr. xx wird in der oberen linken Ecke des Displays angezeigt

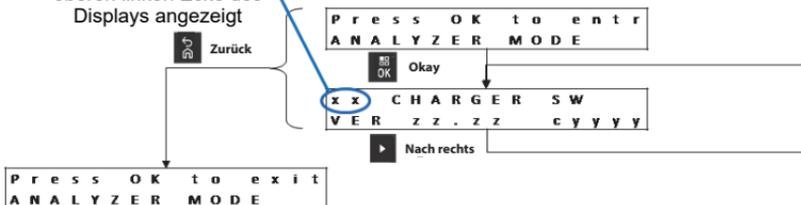

**Abbildung 27:** Analyzer-Mode-Menü für leere Ladeschale (nicht Ladeschale 1)

### Zustandsmeldung des Ladegeräts

Einige IMPRES 2-Akkus sind mit einem Energiesparmodus ausgestattet. Am Ende von „Lithium versenden“, „xx % Langzeitaufbewahrung“ oder „75 % Langzeitaufbewahrung“ wird ein Akku mit Energiesparmodus in diesen versetzt. Mit der Ladezustandsmeldung im Analyzer Mode können Sie den Ladezustand der Akkus im Energiesparmodus überprüfen.



**Tabelle 21:** „Ship Lithium“ aktiviert und der Akku hat die Ladung „Ship Lithium“ abgeschlossen

Neben Ladeschale anzeigen	Ladeschale 1 zeigt andere Ladeschale an
SHIP LI SLEEP xx % Rated Cap	xx SHIP LI SLEEP xx % Rated Cap

**Tabelle 22:** xx % Langzeitaufbewahrung aktiviert und die Akkuladung für die Langzeitaufbewahrung zu xx % abgeschlossen

Neben Ladeschale anzeigen	Ladeschale 1 zeigt andere Ladeschale an
STORAGE SLEEP xx % Rated Cap	xx STORAGE SLEEP xx % Rated Cap

Beispiel: Die Ladezustandsmeldung wird nicht angezeigt, wenn xx % Langzeitaufbewahrung aktiviert ist und die Akkuladung für die Langzeitaufbewahrung in einem anderen Ladegerät zu 75 % abgeschlossen ist.

## Ladegerät-Neuprogrammierung

Für die Ladegerät-Neuprogrammierung muss das Kommunikationsmodul über ein USB-Standardkabel an einen Computer angeschlossen sein. Wird die Ladegerät-Neuprogrammierung mit dem IMPRES Akku-Diversitätsmanagements initiiert, erscheinen die folgenden Meldungen im Ladegerät.

Entfernen Sie die Akkus vor Neuprogrammierung aus den Taschen:

```
REPROGRAMMING
REMOVE BATTERIES
```

Alle Taschen des Ladegeräts sind leer:

```
REPROGRAMMING
WAITING FOR DATA
```

Daten für die Lokalisierungen werden heruntergeladen:

```
REPROGRAMMING
Progress yyy%
```

Bei Ladegeräten, bei denen jeder Schale über ein Display verfügt, ist der Prozentwert der Prozentsatz der Daten, die erfolgreich in die Tasche dieses Displays heruntergeladen wurden. Bei Ladegeräten, die nur ein Display (Schale 1) haben, ist der Prozentwert der Prozentsatz der Daten, die erfolgreich in alle Ladeschalen heruntergeladen wurden.

Neuprogrammierung in der identifizierten Tasche fehlgeschlagen:

```
REPROGRAMMING  
POCKET#xx FAILED
```

Die identifizierte Ladeschale beginnt den Normalbetrieb mit der vorherigen Software.

Download der Daten für Neuprogrammierung ist vollständig abgeschlossen. Das Ladegerät schließt die Neuprogrammierung ab.

```
IMPRES 2  
CHARGER
```

Die Neuprogrammierung wurde erfolgreich abgeschlossen.

```
REPROGRAMMING  
ABGESCHLOSSEN
```

Das Ladegerät beginnt den Normalbetrieb mit der heruntergeladenen Software. Die benutzerdefinierte Einstellung bleibt erhalten, nachdem die Neuprogrammierung des Ladegeräts abgeschlossen wurde.

# Fehlerbehebung Ladegerät

**Tabelle 23:** Fehlerbehebung: Normaler Ladevorgang

Problem	Maßnahme
Die Ladeschalen-LED blinkt beim Einschalten des Ladegeräts ca. 1 Sekunde lang nicht grün.	Stellen Sie sicher, dass das Netzkabel ordnungsgemäß mit dem Ladegerät und einer geeigneten Steckdose verbunden ist. Stellen Sie sicher, dass die Steckdose mit Strom versorgt wird. Untersuchen Sie Sicherungen und tauschen Sie sie gegebenenfalls aus.
Akku oder Funkgerät ist in das Fach eingelegt, aber die Ladeschalen-LED bleibt AUS, und der Akku wird nicht auf dem nebenstehenden Display angezeigt.	Wenn es sich bei der Ladeschale nicht um Ladeschale 1 handelt und der Energiesparmodus aktiviert ist, drücken Sie eine Menütaste. Siehe unten.
Rot blinkende LED und Display (falls verfügbar) zeigt:  NOT CHARGEABLE REMOVE & REINSERT oder ein Motorola Solutions-Akku befindet sich in der Ladeschale, aber das Display (falls verfügbar) zeigt:  UNKNOWN BATTERY	Entfernen Sie den Akku oder das Funkgerät aus der Ladeschale. Prüfen Sie die elektrischen Kontakte am Akku und in der Ladeschale auf Verschmutzung, Korrosion oder physische Schäden. Stellen Sie sicher, dass es sich um einen von Motorola Solutions autorisierten Akku handelt. Andere Akkus werden eventuell nicht geladen. Reinigen Sie die elektrischen Kontakte mit einem trockenen Tuch. Trennen Sie das Ladegerät von der Stromversorgung, und reinigen Sie die elektrischen Kontakte der Ladeschale mit einem trockenen Tuch. Ersetzen Sie den Akku. Wenn der Fehler nicht mehr auftritt, dann nehmen Sie die fehlerhaften Akkus außer Betrieb. Wenn der Fehler auch mit einem anderen Akku weiterhin auftritt, nehmen Sie das Ladegerät außer Betrieb.
Abwechselnd rot/grün leuchtende LED am Ende der Kalibrierung. 	Der IMPRES 2- oder IMPRES-Akku nähert sich möglicherweise dem Ende seiner Lebensdauer. Der Akku ist zwar verwendbar, die verfügbare Kapazität ist jedoch möglicherweise nicht für den intensiven Einsatz über eine längere Zeit geeignet. Gilt nur für den APX NEXT XN-Akku: Der Akku war mehr als 10 Minuten lang hohen Temperaturen ausgesetzt. Es wird empfohlen, den Akku zu entfernen und nicht mehr zu verwenden.

**Tabelle 23:** Fehlerbehebung: Normaler Ladevorgang (Forts.)

Problem	Maßnahme
Abwechselnd rot/grün leuchtende LED für ca. 4 Sekunden, wenn ein Akku in das Ladegerät eingelegt wird. 	Der IMPRES 2- oder IMPRES-Akku erfordert Kalibrierung/ Wiederaufarbeitung. Setzen Sie den Akku bei der nächsten Gelegenheit in ein IMPRES 2-Ladegerät mit aktivierter Kalibrierung ein, und lassen Sie das Ladegerät die Kalibrierung abschließen (dauerhaft grün).
Im Analyzer Mode kann Ladeschale 1 eine andere Ladeschale anzeigen.	Das Ladegerät kann das Display in mindestens einer der anderen Ladeschalen nicht erkennen.

**Tabelle 24:** Fehlerbehebung: Ladung für Langzeitaufbewahrung

Problem	Maßnahme
Rot blinkende LED und Display (falls verfügbar) zeigt: WRONG BATT TYPE CANNOT LT STORE oder CANNOT DISCHARGE CANNOT LT STORE 	Entfernen Sie den Akku aus dem Fach. Stellen Sie sicher, dass der Akku NICHT an ein Funkgerät angeschlossen ist. Stellen Sie sicher, dass es sich um einen IMPRES 2- oder IMPRES-Akku handelt. Andere Akkutypen sind fehlerhaft. Reinigen Sie die elektrischen Kontakte des IMPRES 2- oder IMPRES-Akkus mit einem trockenen Tuch. Trennen Sie das Ladegerät von der Stromversorgung, und reinigen Sie die elektrischen Kontakte der Ladeschale mit einem trockenen Tuch. Tauschen Sie den Akku durch einen anderen IMPRES 2- oder IMPRES-Akku aus. Wenn der Fehler nicht mehr auftritt, dann nehmen Sie die fehlerhaften IMPRES 2- oder IMPRES-Akkus außer Betrieb. Wenn der Fehler auch mit anderen IMPRES 2- oder IMPRES-Akkus weiterhin auftritt, nehmen Sie das Ladegerät außer Betrieb.
Rot blinkende LED und Display (falls verfügbar) zeigt: STORE INCOMPLETE Low Capacity:yy% 	Die potenzielle Kapazität des IMPRES 2- oder IMPRES-Akkus kann geringer sein als die Auswahl für Langzeitaufbewahrung. Der Akku nähert sich möglicherweise dem Ende der Lebensdauer.

**Tabelle 24:** Fehlerbehebung: Ladung für Langzeitaufbewahrung (Forts.)

Problem	Maßnahme
<p>Rot blinkende LED und Display (falls verfügbar) zeigt:</p> <p>RADIO POCKET CANNOT LT STORE</p> <p>oder</p> <p>LADESCHALE CANNOT LT STORE</p>	<p>Die Ladeschale ist nicht die Standardladeschale zum Laden eines Akkus (durch elektrische Kontakte zwischen Ladegerät und Akku).</p> <ul style="list-style-type: none"> <li>• Eine Ladeschale für Funkgeräte ist eine spezielle Ladeschale, in der der Akku an ein Funkgerät angeschlossen ist, sich keine externen Kontakte am Akku befinden und der Akku über elektrische Kontakte am Funkgerät geladen wird.</li> <li>• Eine Ladeschale ist eine Ladeschale, die Energie des Ladegeräts für spezielle Zwecke nutzt, z. B. als USB-Ladeanschluss.</li> </ul> <p>Legen Sie den Akku in eine Standardladeschale ein, oder ersetzen Sie die Funkgerät-Ladeschale oder die Ladetasche durch eine Standard-Ladeschale.</p>

**Tabelle 25:** Fehlerbehebung: Ladung „Ship Lithium“

Problem	Maßnahme
<p>Rot blinkende LED und Display (falls verfügbar) zeigt:</p> <p>WRONG BATT TYPE CANNOT SHIP LI</p>	<p>Entfernen Sie den Akku aus dem Fach. Stellen Sie sicher, dass der Akku NICHT an ein Funkgerät angeschlossen ist.</p> <p>Stellen Sie sicher, dass es sich um einen IMPRES 2-, IMPRES- oder anderen von Motorola Solutions genehmigten Akku handelt. Andere Akkutypen sind fehlerhaft.</p> <p>Reinigen Sie die elektrischen Kontakte des IMPRES 2-, IMPRES- oder anderen von Motorola Solutions genehmigten Lithium-Ionen-Akkus mit einem trockenen Tuch.</p> <p>Trennen Sie das Ladegerät von der Stromversorgung, und reinigen Sie die elektrischen Kontakte der Ladeschale mit einem trockenen Tuch.</p> <p>Tauschen Sie den Akku durch einen IMPRES 2-, IMPRES- oder anderen von Motorola Solutions genehmigten Lithium-Ionen-Akku aus. Wenn der Fehler nicht mehr besteht, nehmen Sie die fehlerhaften IMPRES 2-, IMPRES- oder anderen von Motorola Solutions genehmigten Lithium-Ionen-Akkus außer Betrieb.</p> <p>Wenn der Fehler mit dem IMPRES 2-, IMPRES- oder anderen von Motorola Solutions genehmigten Lithium-Ionen-Ersatzakku weiterhin besteht, nehmen Sie das Ladegerät außer Betrieb.</p>

**Tabelle 25:** Fehlerbehebung: Ladung „Ship Lithium“ (Forts.)

Problem	Maßnahme
Rot blinkende LED und Display (falls verfügbar) zeigt: SHIP INCOMPLETE Low Capacity:yy%	 Die potenzielle Kapazität des Lithium-Ionen-Originalakkus von Motorola Solutions liegt möglicherweise unter dem Grenzwert von „Ship Lithium“. Der Akku nähert sich möglicherweise dem Ende der Lebensdauer.
Rot blinkende LED und Display (falls verfügbar) zeigt: RADIO POCKET CANNOT LT STORE oder LADESCHALE CANNOT SHIP LI	 Die Ladeschale ist nicht die Standardladeschale zum Laden eines Akkus (durch elektrische Kontakte zwischen Ladegerät und Akku). <ul style="list-style-type: none"> <li>• Eine Ladeschale für Funkgeräte ist eine spezielle Ladeschale, in der der Akku an ein Funkgerät angeschlossen ist, sich keine externen Kontakte am Akku befinden und der Akku über elektrische Kontakte am Funkgerät geladen wird.</li> <li>• Eine Ladeschale ist eine Ladeschale, die Energie des Ladegeräts für spezielle Zwecke nutzt, z. B. als USB-Ladeanschluss.</li> </ul> Legen Sie den Akku in eine Standardladeschale ein, oder ersetzen Sie die Funkgerät-Ladeschale oder die Ladetasche durch eine Standard-Ladeschale.

## IMPRES Battery Fleet Management-System

Deutsch

Die Software des IMPRES-Akku-Managementsystems erfasst automatisch kritische Daten von IMPRES- oder IMPRES 2-Akkus, die in ein IMPRES-Ladegerät eingelegt werden. Die kritischen Daten umfassen Akkualter, Kapazität, Ladeverlauf, Kalibrierungs-/Wiederaufarbeitungsverlauf, Herstellungsdatum und Datum der Inbetriebnahme. Die Software des IMPRES Battery Fleet Management-Systems analysiert Akkudaten, kommuniziert den Akkuzustand und empfiehlt, wann Sie den Akku ersetzen sollten. Infolgedessen können Sie schnell und effizient festlegen, ob der Akku bei einem weniger anspruchsvollen Benutzer eingesetzt wird, wann ein Ersatzakku gekauft werden muss oder wann nach einem fehlenden Akku gesucht werden muss.

Das IMPRES Battery Fleet Management-System liefert wichtige Akkuinformationen:

- Wenn der Akkuladezustand unter einen kritischen Wert fällt.
- Sorgt dafür, dass Benutzer über ausreichend Kapazität für eine ganze Schicht verfügen.
- Identifiziert Akkus mit geringer Kapazität, sodass sie außer Betrieb genommen werden können.
- Vermeidet unerwartete Ausfallzeiten und Arbeitsunterbrechungen.
- Vermeidet die Kosten, die mit der vorzeitigen Entsorgung von Akkus verbunden sind.
- Bestätigt, dass Ladegeräte optimal verteilt sind und verwendet werden.

Die Anwendungssoftware des IMPRES Battery Fleet Management-Systems kann von einem einzelnen Standort auf ein vernetztes System mit mehreren Standorten skaliert werden, wie in Abbildung 28 dargestellt. Das IMPRES Battery Fleet Management-System unterstützt:

- Einen Systemadministrator-Server
- 19 Remote-Clients
- 25 IMPRES-Ladegeräte oder IMPRES-Akkulesegeräte pro Client
- 25.000 IMPRES-Akkus befinden sich am gleichen Standort oder über geografisch verteilte Bereiche (die Gesamtanzahl der Akkus für das gesamte System darf 25.000 nicht überschreiten).

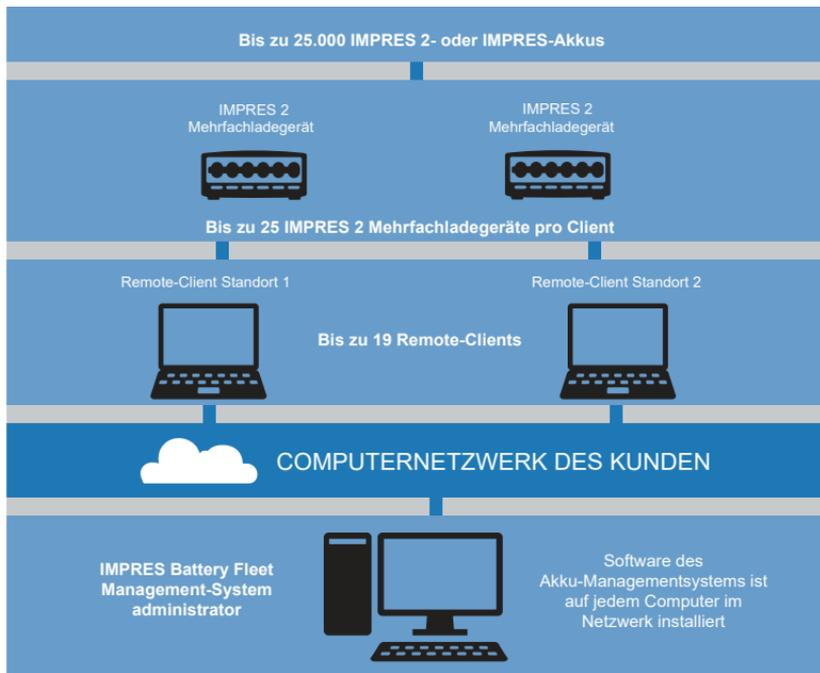

**Abbildung 28:** IMPRES Battery Fleet Management über Netzwerk-Ladegeräte

Das IMPRES Battery Fleet Management-System besteht aus drei Hauptkomponenten:

- Der Anwendungssoftware.
- Einem Softwarelizenzschlüssel.
- Ein USB-Kabel zum Anschließen des IMPRES 2-Ladegeräts, des IMPRES 2-Kommunikationsmoduls, der IMPRES-Ladegeräte-Interfaceeinheit (CIU) oder des IMPRES-Akku-Daten-Lesegeräts an einen Computer, der einen Remote-Client hostet.



Passen Sie neue anhand der vorhandenen Berichte an, um die relevantesten Informationen für Ihr Unternehmen zu erhalten. Die Daten werden in Ihrer Datenbank gespeichert und kann in eine Excel-Tabelle™ exportiert oder ausgedruckt werden. Die Software des IMPRES Battery Fleet Management-Systems erfasst und organisiert eine Vielzahl von Daten. So können Sie:

- Einen Schnappschuss Ihrer gesamten Akkuflotte anzeigen.
- Beurteilen, ob die Akkus Ihre Leistungskriterien erfüllen.
- Festlegen, wann die Akkus das Ende ihrer Lebensdauer erreichen.
- Entscheiden, wann genau neue Akkus gekauft werden.
- Einen Bericht über verlorene Akkus abrufen.
- Ihre Ladegerätauslastung optimieren.
- Alle Geräte im System überwachen.

The screenshot shows the 'Active Batteries' report in the IMPRES Battery Fleet Management software. The table lists various battery units with their respective details.

Serial Number	Group	Radio Family	ID Number	Chemistry	Fitted	Potential Capacity	Date of First Use
5100000204709	Sam	Building 1	XTS 3000/2000/2000	HMM90118	NCSE	No	1123
5100000204840	Matt	Security	APR	WNTN7975A	NaISe	No	1680
5100000204948	Inf-lead	Security	APR	WNTN7975A	NaISe	Yes	2009
5100000205011	Phil	Administration	HCTGT7800 Series	HMM90248	NCSE	No	1245
5100000205112	Patte	Building 1	XTS 3000/2000/2000	WNTN4407B	NaISe	Yes	1700
5100000204955	Steve	Building 1	XTS 2500, WTS/MF/JR 1850	WNTN7975A	Li-Ion	No	2009
5100000204961	Adam	None	Galve	HMM90128	NCSE	No	2009
5100000204978	Mark	Building 2	XTS 2500, WTS/MF/JR 1850	WNTN7975A	Li-Ion	No	2009
5100000204982	John	Building 2	XTS 2500, WTS/MF/JR 1850	WNTN7975A	Li-Ion	No	2009
5100000204983	John	None	Galve	HMM90128	NCSE	Yes	2009
5100000205011	Carroll	Administration	HCTGT7800 Series	HMM90248	NaISe	Yes	1890
5100000205012	Carroll	Building 1	XTS 3000/2000/2000	WNTN7975A	NaISe	Yes	2009
5100000205013	Carroll	Building 1	XTS 3000/2000/2000	WNTN7975A	NaISe	Yes	2009
5100000205014	Carroll	Building 1	XTS 3000/2000/2000	WNTN7975A	NaISe	Yes	2009
5100000205015	Carroll	Building 1	XTS 3000/2000/2000	WNTN7975A	NaISe	Yes	2009
5100000205016	Carroll	Building 1	XTS 3000/2000/2000	WNTN7975A	NaISe	Yes	2009
5100000205017	Carroll	Building 1	XTS 3000/2000/2000	WNTN7975A	NaISe	Yes	2009
5100000205018	Carroll	Building 1	XTS 3000/2000/2000	WNTN7975A	NaISe	Yes	2009
5100000205019	Carroll	Building 1	XTS 3000/2000/2000	WNTN7975A	NaISe	Yes	2009
5100000205020	Carroll	Building 1	XTS 3000/2000/2000	WNTN7975A	NaISe	Yes	2009
5100000205021	Carroll	Building 1	XTS 3000/2000/2000	WNTN7975A	NaISe	Yes	2009
5100000205022	Carroll	Building 1	XTS 3000/2000/2000	WNTN7975A	NaISe	Yes	2009
5100000205023	Carroll	Building 1	XTS 3000/2000/2000	WNTN7975A	NaISe	Yes	2009
5100000205024	Carroll	Building 1	XTS 3000/2000/2000	WNTN7975A	NaISe	Yes	2009
5100000205025	Carroll	Building 1	XTS 3000/2000/2000	WNTN7975A	NaISe	Yes	2009
5100000205026	Carroll	Building 1	XTS 3000/2000/2000	WNTN7975A	NaISe	Yes	2009
5100000205027	Carroll	Building 1	XTS 3000/2000/2000	WNTN7975A	NaISe	Yes	2009
5100000205028	Carroll	Building 1	XTS 3000/2000/2000	WNTN7975A	NaISe	Yes	2009
5100000205029	Carroll	Building 1	XTS 3000/2000/2000	WNTN7975A	NaISe	Yes	2009
5100000205030	Carroll	Building 1	XTS 3000/2000/2000	WNTN7975A	NaISe	Yes	2009
5100000205031	Carroll	Building 1	XTS 3000/2000/2000	WNTN7975A	NaISe	Yes	2009
5100000205032	Carroll	Building 1	XTS 3000/2000/2000	WNTN7975A	NaISe	Yes	2009
5100000205033	Carroll	Building 1	XTS 3000/2000/2000	WNTN7975A	NaISe	Yes	2009
5100000205034	Carroll	Building 1	XTS 3000/2000/2000	WNTN7975A	NaISe	Yes	2009
5100000205035	Carroll	Building 1	XTS 3000/2000/2000	WNTN7975A	NaISe	Yes	2009
5100000205036	Carroll	Building 1	XTS 3000/2000/2000	WNTN7975A	NaISe	Yes	2009
5100000205037	Carroll	Building 1	XTS 3000/2000/2000	WNTN7975A	NaISe	Yes	2009
5100000205038	Carroll	Building 1	XTS 3000/2000/2000	WNTN7975A	NaISe	Yes	2009
5100000205039	Carroll	Building 1	XTS 3000/2000/2000	WNTN7975A	NaISe	Yes	2009
5100000205040	Carroll	Building 1	XTS 3000/2000/2000	WNTN7975A	NaISe	Yes	2009
5100000205041	Carroll	Building 1	XTS 3000/2000/2000	WNTN7975A	NaISe	Yes	2009
5100000205042	Carroll	Building 1	XTS 3000/2000/2000	WNTN7975A	NaISe	Yes	2009
5100000205043	Carroll	Building 1	XTS 3000/2000/2000	WNTN7975A	NaISe	Yes	2009
5100000205044	Carroll	Building 1	XTS 3000/2000/2000	WNTN7975A	NaISe	Yes	2009
5100000205045	Carroll	Building 1	XTS 3000/2000/2000	WNTN7975A	NaISe	Yes	2009
5100000205046	Carroll	Building 1	XTS 3000/2000/2000	WNTN7975A	NaISe	Yes	2009
5100000205047	Carroll	Building 1	XTS 3000/2000/2000	WNTN7975A	NaISe	Yes	2009
5100000205048	Carroll	Building 1	XTS 3000/2000/2000	WNTN7975A	NaISe	Yes	2009
5100000205049	Carroll	Building 1	XTS 3000/2000/2000	WNTN7975A	NaISe	Yes	2009
5100000205050	Carroll	Building 1	XTS 3000/2000/2000	WNTN7975A	NaISe	Yes	2009
5100000205051	Carroll	Building 1	XTS 3000/2000/2000	WNTN7975A	NaISe	Yes	2009
5100000205052	Carroll	Building 1	XTS 3000/2000/2000	WNTN7975A	NaISe	Yes	2009
5100000205053	Carroll	Building 1	XTS 3000/2000/2000	WNTN7975A	NaISe	Yes	2009
5100000205054	Carroll	Building 1	XTS 3000/2000/2000	WNTN7975A	NaISe	Yes	2009
5100000205055	Carroll	Building 1	XTS 3000/2000/2000	WNTN7975A	NaISe	Yes	2009
5100000205056	Carroll	Building 1	XTS 3000/2000/2000	WNTN7975A	NaISe	Yes	2009
5100000205057	Carroll	Building 1	XTS 3000/2000/2000	WNTN7975A	NaISe	Yes	2009
5100000205058	Carroll	Building 1	XTS 3000/2000/2000	WNTN7975A	NaISe	Yes	2009
5100000205059	Carroll	Building 1	XTS 3000/2000/2000	WNTN7975A	NaISe	Yes	2009
5100000205060	Carroll	Building 1	XTS 3000/2000/2000	WNTN7975A	NaISe	Yes	2009
5100000205061	Carroll	Building 1	XTS 3000/2000/2000	WNTN7975A	NaISe	Yes	2009
5100000205062	Carroll	Building 1	XTS 3000/2000/2000	WNTN7975A	NaISe	Yes	2009
5100000205063	Carroll	Building 1	XTS 3000/2000/2000	WNTN7975A	NaISe	Yes	2009
5100000205064	Carroll	Building 1	XTS 3000/2000/2000	WNTN7975A	NaISe	Yes	2009
5100000205065	Carroll	Building 1	XTS 3000/2000/2000	WNTN7975A	NaISe	Yes	2009
5100000205066	Carroll	Building 1	XTS 3000/2000/2000	WNTN7975A	NaISe	Yes	2009
5100000205067	Carroll	Building 1	XTS 3000/2000/2000	WNTN7975A	NaISe	Yes	2009
5100000205068	Carroll	Building 1	XTS 3000/2000/2000	WNTN7975A	NaISe	Yes	2009
5100000205069	Carroll	Building 1	XTS 3000/2000/2000	WNTN7975A	NaISe	Yes	2009
5100000205070	Carroll	Building 1	XTS 3000/2000/2000	WNTN7975A	NaISe	Yes	2009
5100000205071	Carroll	Building 1	XTS 3000/2000/2000	WNTN7975A	NaISe	Yes	2009
5100000205072	Carroll	Building 1	XTS 3000/2000/2000	WNTN7975A	NaISe	Yes	2009
5100000205073	Carroll	Building 1	XTS 3000/2000/2000	WNTN7975A	NaISe	Yes	2009
5100000205074	Carroll	Building 1	XTS 3000/2000/2000	WNTN7975A	NaISe	Yes	2009
5100000205075	Carroll	Building 1	XTS 3000/2000/2000	WNTN7975A	NaISe	Yes	2009
5100000205076	Carroll	Building 1	XTS 3000/2000/2000	WNTN7975A	NaISe	Yes	2009
5100000205077	Carroll	Building 1	XTS 3000/2000/2000	WNTN7975A	NaISe	Yes	2009
5100000205078	Carroll	Building 1	XTS 3000/2000/2000	WNTN7975A	NaISe	Yes	2009
5100000205079	Carroll	Building 1	XTS 3000/2000/2000	WNTN7975A	NaISe	Yes	2009
5100000205080	Carroll	Building 1	XTS 3000/2000/2000	WNTN7975A	NaISe	Yes	2009
5100000205081	Carroll	Building 1	XTS 3000/2000/2000	WNTN7975A	NaISe	Yes	2009
5100000205082	Carroll	Building 1	XTS 3000/2000/2000	WNTN7975A	NaISe	Yes	2009
5100000205083	Carroll	Building 1	XTS 3000/2000/2000	WNTN7975A	NaISe	Yes	2009
5100000205084	Carroll	Building 1	XTS 3000/2000/2000	WNTN7975A	NaISe	Yes	2009
5100000205085	Carroll	Building 1	XTS 3000/2000/2000	WNTN7975A	NaISe	Yes	2009
5100000205086	Carroll	Building 1	XTS 3000/2000/2000	WNTN7975A	NaISe	Yes	2009
5100000205087	Carroll	Building 1	XTS 3000/2000/2000	WNTN7975A	NaISe	Yes	2009
5100000205088	Carroll	Building 1	XTS 3000/2000/2000	WNTN7975A	NaISe	Yes	2009
5100000205089	Carroll	Building 1	XTS 3000/2000/2000	WNTN7975A	NaISe	Yes	2009
5100000205090	Carroll	Building 1	XTS 3000/2000/2000	WNTN7975A	NaISe	Yes	2009
5100000205091	Carroll	Building 1	XTS 3000/2000/2000	WNTN7975A	NaISe	Yes	2009
5100000205092	Carroll	Building 1	XTS 3000/2000/2000	WNTN7975A	NaISe	Yes	2009
5100000205093	Carroll	Building 1	XTS 3000/2000/2000	WNTN7975A	NaISe	Yes	2009
5100000205094	Carroll	Building 1	XTS 3000/2000/2000	WNTN7975A	NaISe	Yes	2009
5100000205095	Carroll	Building 1	XTS 3000/2000/2000	WNTN7975A	NaISe	Yes	2009
5100000205096	Carroll	Building 1	XTS 3000/2000/2000	WNTN7975A	NaISe	Yes	2009
5100000205097	Carroll	Building 1	XTS 3000/2000/2000	WNTN7975A	NaISe	Yes	2009
5100000205098	Carroll	Building 1	XTS 3000/2000/2000	WNTN7975A	NaISe	Yes	2009
5100000205099	Carroll	Building 1	XTS 3000/2000/2000	WNTN7975A	NaISe	Yes	2009
5100000205100	Carroll	Building 1	XTS 3000/2000/2000	WNTN7975A	NaISe	Yes	2009

Abbildung 29: Bericht zur Akkuaktivität

Deutsch



Abbildung 30: Verwendete Akkus nach Funkgerätfamilie



Abbildung 31: Verlorener Akku nach Standort

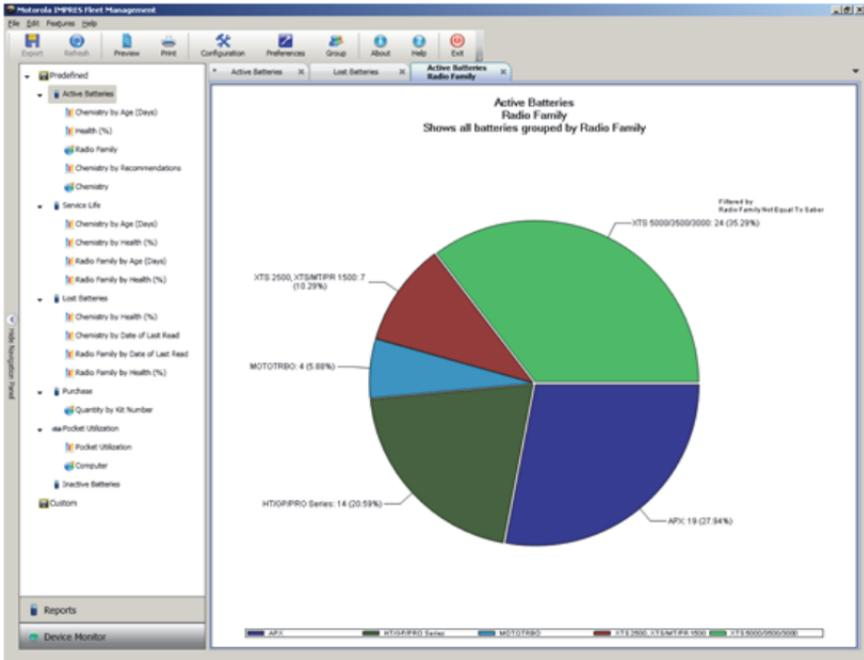

Abbildung 32: Ladeschalenauslastung

## Wandhalterung für Mehrfachladegerät

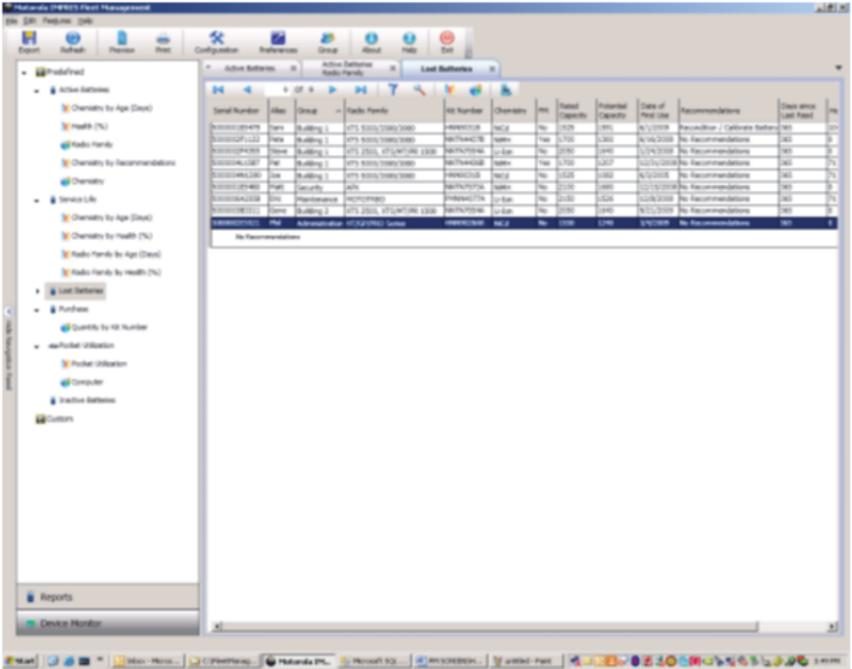
Für das Mehrfachladegerät ist eine Wandhalterung (Teile-Nr.: 0705559L01) erhältlich. Wenden Sie sich an Ihren Händler vor Ort, um diesen Artikel zu bestellen. Die Montage wird unten dargestellt.

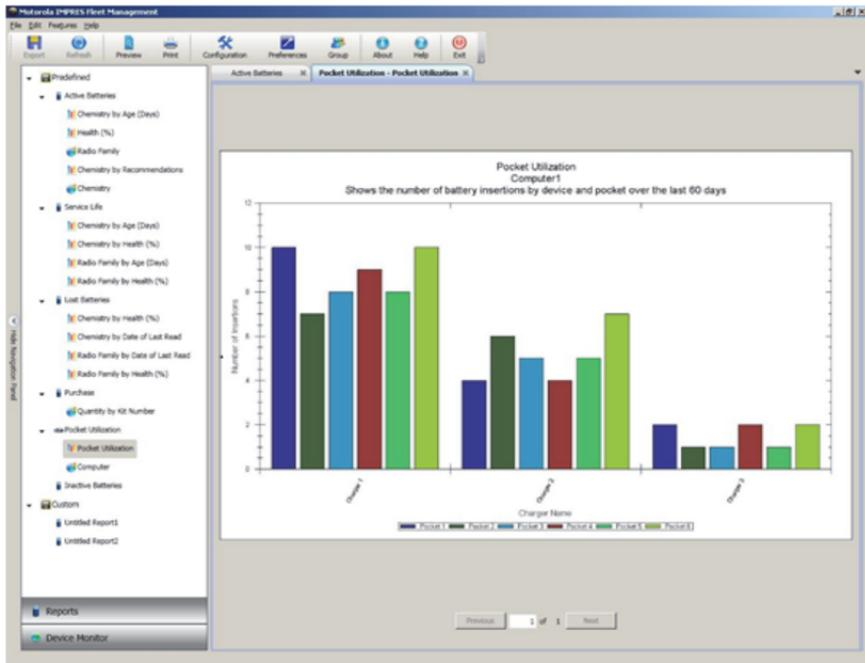

- Die Wandhalterung muss von einem geschulten und erfahrenen Techniker montiert werden. Die Montage des Produkts von einem nicht darauf spezialisierten Techniker ist sehr gefährlich und kann zu Schäden oder Verletzungen führen.
- Montieren Sie das Produkt nicht an Stellen, die das Gewicht nicht tragen können. Wenn die Stelle, an der die Wandhalterung montiert wird, das Gewicht nicht tragen kann, kann die Wandhalterung herunterfallen und Verletzungen verursachen.
- Montieren Sie die Wandhalterung nicht auf einer Struktur, die Vibrationen, Bewegungen oder möglichen Stößen ausgesetzt ist.

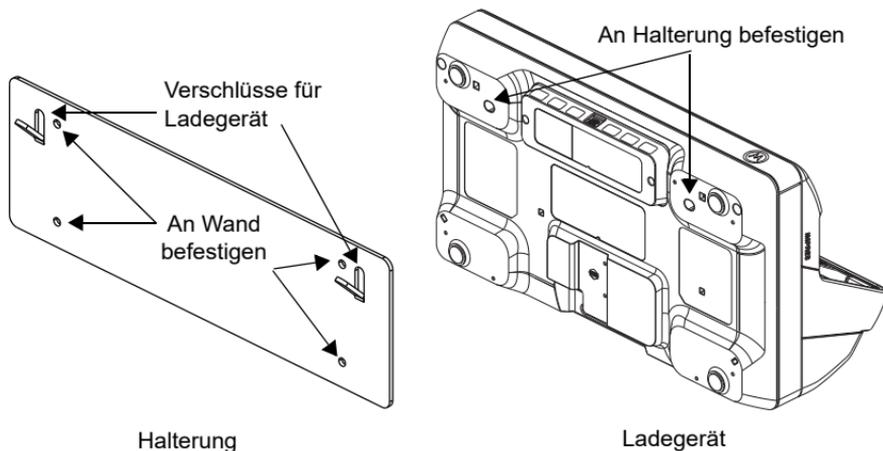

**Abbildung 33:** Position der Bohrungen für die Halterung und der Verschlüsse

## Montage des Mehrfachladegeräts an die Wandhalterung

1. Positionieren Sie die Wandhalterung an der gewünschten Stelle, und markieren Sie die Position der Befestigungslöcher an der Wand.



Stellen Sie vor dem Schneiden, Bohren oder Einbringen der Befestigungsschrauben sicher, dass sich in dem Bereich hinter der Montagefläche keine elektrischen Leitungen, Kabel oder Rohre befinden.

2. Befestigen Sie die Halterung mit Montageschrauben, die für die Wandbefestigung geeignet sind, an der sie angebracht werden soll. Nehmen Sie die Bohrungen anhand der an der Wand markierten Befestigungslöcher vor.
3. Befestigen Sie die Wandhalterung an der entsprechenden Position, indem Sie die Montageschrauben fest in die Befestigungslöcher der Wandhalterung schrauben.

**Hinweis:** Es wird empfohlen, Schneidschrauben und Unterlegscheiben von 10-16x1,5 Zoll (nicht im Lieferumfang enthalten) auf Holzbalken und massiven, flachen Beton-/Ziegelwänden zu verwenden.

4. Hängen Sie das Mehrfachladegerät in die Wandhalterung.

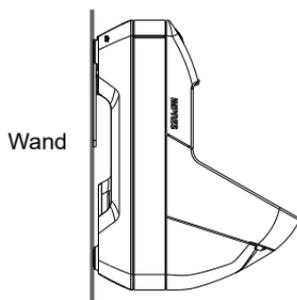

**Abbildung 34:** Ladegerät an Wandhalterung montiert

# Notizen

# CONSIGNES DE SÉCURITÉ IMPORTANTES

## Conservez précieusement ces instructions

Ce document contient des consignes d'utilisation et de sécurité importantes. Veuillez les lire attentivement et les conserver pour pouvoir vous y référer ultérieurement.

Avant d'utiliser le chargeur de batterie, lisez toutes les instructions et mises en garde sur (1) le chargeur, (2) la batterie et (3) la radio utilisant la batterie.



**AVERTISSEMENT**

1. Pour réduire le risque d'endommagement du cordon d'alimentation, il est recommandé de tirer sur la fiche et non sur le cordon pour débrancher le chargeur de la prise secteur.
2. N'utilisez pas de rallonge pour brancher le chargeur, sauf en cas d'absolue nécessité. En effet, l'utilisation d'une rallonge défectueuse pourrait provoquer des risques d'incendie et de décharge électrique. Si vous devez utiliser une rallonge, veillez à utiliser un câble 18 AWG pour les longueurs de 2 mètres maximum et un câble 16 AWG pour les longueurs de 3 mètres maximum.
3. Afin de réduire les risques d'incendie, de décharge électrique ou de blessure, n'utilisez pas le chargeur s'il est cassé ou endommagé. Confiez-le à un technicien de maintenance Motorola Solutions agréé.
4. Ne tentez jamais de démonter le chargeur. Démonter le chargeur peut entraîner un risque d'électrocution ou d'incendie. Les seules pièces réparables/remplaçables sont les inserts de compartiments NNTN9212 et NNTN9213. Suivez les instructions des kits d'inserts de compartiments de chargeur pour unités multiples IMPRES 2 de la série APX MN005697A01.
5. Pour éviter tout risque d'électrocution, débranchez le chargeur de la prise secteur avant de tenter d'effectuer toute opération d'entretien ou de nettoyage.
6. Pour réduire le risque de blessure, chargez uniquement des batteries rechargeables agréées par Motorola Solutions et répertoriées dans le Tableau 2. D'autres batteries risquent d'exploser et de provoquer des dommages matériels ou physiques.
7. L'utilisation d'accessoires non agréés par Motorola Solutions peut présenter un risque d'incendie, de décharge électrique ou de blessure.



## Consignes de sécurité lors du fonctionnement

- Cet appareil n'est pas adapté à une utilisation en extérieur. Utilisez-le uniquement dans des conditions et environnements secs.
- La température ambiante maximale autour du chargeur ne doit pas dépasser 40 °C (104 °F).
- Lorsqu'une radio se trouve dans un compartiment de charge, celle-ci peut être mise sous tension uniquement lorsqu'elle émet des données sans fil (via une connexion Wi-Fi, par exemple). Dans le cas contraire, mettez la radio hors tension.
- Connectez toujours le chargeur à une alimentation appropriée (voir le Tableau 3).
- La prise secteur à laquelle est connecté le cordon d'alimentation doit être proche et facilement accessible.
- Vérifiez que le cordon d'alimentation auquel est branché le chargeur est placé de façon à ce que personne ne puisse le piétiner ou qu'il ne risque de faire trébucher personne et à ce qu'il ne soit pas mouillé, endommagé ou soumis à d'autres contraintes.
- Connectez uniquement le cordon d'alimentation à une prise secteur correctement câblée, protégée par un fusible et dont la tension est correcte, c'est-à-dire telle qu'indiquée sur le produit.
- Débranchez l'appareil de la source d'alimentation en déconnectant le cordon d'alimentation de la prise secteur.
- Ne connectez pas plus du nombre de chargeurs autorisés à un circuit de 15 A ou 20 A, selon les limites de toute multiprise certifiée que vous utiliserez. Les multiprises en série ne sont PAS RECOMMANDÉES. La limite de charge du circuit doit être inférieure à 80 % de la tension nominale du circuit.
- Utilisez uniquement des compartiments agréés par Motorola Solutions.

## Modèles pris en charge

**Tableau 1 : Modèles pris en charge et leur description**

Modèle	Description
PS000029A01 (UNIV) PS000029A04 (UE/RU) PS000029A06 (KR)	Série APX – Chargeur pour unités multiples IMPRES 2 à un seul écran avec reprogrammation du chargeur et Fleet Management
PS000029A02 (UNIV) PS000029A05 (UE/RU) PS000029A07 (KR)	Série APX – Chargeur pour unités multiples IMPRES 2 à 6 écrans avec reprogrammation du chargeur et Fleet Management
PS000029A03 (UE/RU) PS000029A08 (KR)	Série APX – Chargeur pour unités multiples IMPRES 2 à 6 écrans avec reprogrammation du chargeur, Fleet Management et charge des accessoires USB
PS000337A01 (États-Unis/Amérique du Nord, Australie/Nouvelle-Zélande)	Série APX – Chargeur pour unités multiples IMPRES 2 à 6 écrans avec reprogrammation du chargeur et Fleet Management

## Batteries agréées par Motorola Solutions

Les chargeurs IMPRES 2 de la série APX chargent les batteries répertoriées dans le Tableau 2. Les batteries peuvent être autonomes ou fixées à une radio.

**Tableau 2 : Batteries agréées par Motorola Solutions**

Kit (réf.)	Description
NNTN7033	IMPRES Li-Ion FM (HazLoc) IP67 4 100 mAh
NNTN7034	IMPRES Li-Ion IP67 4 200 mAh
NNTN7035	IMPRES NiMH FM (HazLoc) renforcée 2 000 mAh
NNTN7036	IMPRES NiMH FM (HazLoc) IP67 2 000 mAh
NNTN7037	IMPRES NiMH IP67 2 100 mAh
NNTN7038	IMPRES Li-Ion IP67 2 900 mAh
NNTN7573	IMPRES NiMH renforcée 2 100 mAh
NNTN8092	IMPRES Li-Ion FM (HazLoc) renforcée 2 300 mAh
NNTN8182	IMPRES Li-Ion renforcée 2 900 mAh
NNTN8921	IMPRES 2 Li-Ion TIA4950 (HazLoc) renforcée IP67 3 700 mAh
NNTN8930	IMPRES 2 Li-Ion TIA4950 (HazLoc) renforcée IP67 2 700 mAh

**Tableau 2 : Batteries agréées par Motorola Solutions (Suite)**

Kit (réf.)	Description
NNTN9087	IMPRES 2 Li-Ion IP68 3 800 mAh
NNTN9088	IMPRES 2 Li-Ion DIVISION 2 (HazLoc) IP68 3 800 mAh
NNTN9089	IMPRES 2 Li-Ion IP68 5 650 mAh
NNTN9090	IMPRES 2 Li-Ion DIVISION 2 (HazLoc) IP68 5 650 mAh
NNTN9126	IMPRES 2 Li-Ion IP68 4 400 mAh
NNTN9127	IMPRES 2 Li-Ion DIVISION 2 (HazLoc) IP68 4 400 mAh
PMNN4403	IMPRES Li-Ion IP67 2 150 mAh
PMNN4485	IMPRES 2 Li-Ion renforcée IP67 2 500 mAh
PMNN4486	IMPRES 2 Li-Ion renforcée IP67 3 400 mAh
PMNN4487	IMPRES 2 Li-Ion renforcée IP67 4 400 mAh
PMNN4494	IMPRES 2 Li-Ion renforcée IP67 5 000 mAh
PMNN4504	IMPRES 2 Li-Ion DIVISION 2 (HazLoc) renforcée IP67 3 400 mAh
PMNN4505	IMPRES 2 Li-Ion DIVISION 2 (HazLoc) renforcée IP67 4 850 mAh
PMNN4547	IMPRES 2 Li-Ion TIA4950 (HazLoc) renforcée IP68 3 100 mAh
PMNN4573	IMPRES 2 Li-Ion TIA4950 (HazLoc) renforcée IP68 4 600 mAh
PMNN4812	APX NEXT XN IMPRES 2 Li-Ion DIV 2 (HazLoc) IP68 3 400 mAh

## Blocs d'alimentation agréés par Motorola Solutions

**Tableau 3 : Blocs d'alimentation agréés par Motorola Solutions**

Kit (réf.)	Description
3087791G01	Cordon d'alimentation, États-Unis/Amérique du Nord
3087791G04	Cordon d'alimentation, Union européenne
3087791G07	Cordon d'alimentation, Royaume-Uni/Hong-Kong
3087791G10	Cordon d'alimentation, Australie/Nouvelle-Zélande
3087791G13	Cordon d'alimentation, Argentine
3087791G16	Cordon d'alimentation, Corée
3087791G20	Cordon d'alimentation, Japon
3087791G22	Cordon d'alimentation, Brésil
CB000460A01	Cordon d'alimentation, Suisse

# Modules de communication agréés par Motorola Solutions

**Tableau 4 : Modules de communication agréés par Motorola Solutions**

Kit (réf.)	Description
AS000013A01	Module Battery Fleet Management/reprogrammation du chargeur IMPRES 2
AS000012A02	Module de chargement d'accessoires et Battery Fleet Management/reprogrammation du chargeur IMPRES 2

## Chargeur, compartiment et module de communication

Le système de chargeur adaptatif IMPRES 2™ de la série APX est un système d'entretien des batteries entièrement automatisé. Le chargeur présente les caractéristiques suivantes :

- Charge adaptative acceptant plusieurs types de batterie, y compris les batteries IMPRES 2, batteries IMPRES™ et autres batteries Motorola Solutions authentiques.
- Compartiment pouvant accueillir une batterie autonome ou une radio avec sa batterie.
- Indicateur LED rouge/orange/vert indiquant l'état du compartiment du chargeur.
- Module de communication
  - Reprogrammation du chargeur
  - Chargement des données de batterie IMPRES ou IMPRES 2 vers un système Battery Fleet Management IMPRES
  - (En option) Six ports de charge USB de type A, 0,5 A chacun, pour la charge d'accessoires USB
- Menu du clavier
  - Configuration du chargeur
  - Analyse de la batterie
- Affichage d'informations sur le compartiment 1
  - Écrans en option sur les autres compartiments
- Préparation d'une batterie IMPRES ou IMPRES 2 autonome pour le stockage à long terme ou d'une batterie lithium-ion Motorola Solutions autonome pour l'expédition. **NE LAISSEZ PAS** les batteries dans le chargeur une fois la préparation pour le stockage à long terme ou l'expédition lithium-ion terminée.

- Fonctions d'économie d'énergie
  - Conforme aux normes d'appliances de la Commission californienne de l'énergie (California Energy Commission) concernant les petits systèmes de charge de batteries. Les compartiments du chargeur se mettent en veille, puis se réactivent automatiquement en réponse à une action de l'utilisateur ou pour charger une batterie placée dans un compartiment.
  - Conforme aux limites européennes de consommation électrique en mode veille (kit de chargeur européen). Lorsque le mode Power Saver est activé, tous les compartiments du chargeur, à l'exception du compartiment 1, s'éteignent automatiquement en cas d'absence d'activité pendant un certain laps de temps. Appuyez sur n'importe quelle touche du clavier pour remettre sous tension ces compartiments.
- Taux de charge des batteries au lithium-ion IMPRES 2 plus élevé.
- Charge plus rapide.
- Durée de vie de la batterie prolongée.

Il est déconseillé d'utiliser une radio lorsqu'elle est dans le chargeur.

L'utilisation de la radio au cours du processus de charge peut entraîner une réduction des performances de la radio et une augmentation du temps de charge de la batterie.

Lors du calibrage/reconditionnement, la batterie est entièrement déchargée avant d'être à nouveau complètement chargée. Par conséquent, la radio peut s'éteindre au cours du processus de déchargement. Il est recommandé de calibrer la batterie sans la radio connectée ou lorsque la radio connectée est éteinte.

## Batteries et chargeurs IMPRES 2 et IMPRES

### Fonctionnalités et avantages

La solution d'alimentation IMPRES 2 est un système d'alimentation avancé à trois composants chimiques conçu par Motorola Solutions. Ce système comprend :

- Batteries IMPRES 2 et IMPRES
- Chargeur adaptatif IMPRES 2
- Radios IMPRES

La charge des batteries IMPRES 2 ou IMPRES à l'aide d'un chargeur adaptatif IMPRES 2, qui effectue régulièrement le calibrage ou le reconditionnement de la batterie, offre les avantages suivants :

- Prolonge le cycle de vie de la batterie.
- Mesure la capacité de la batterie et détermine l'état de charge actuel de la batterie, ce qui vous donne une indication de la durée d'utilisation possible.
- Surveille le modèle d'utilisation de la batterie IMPRES 2 ou IMPRES.
- Met à jour les données de modèle stockées dans la batterie IMPRES 2 ou IMPRES.
- Effectue automatiquement le calibrage/reconditionnement, et ce, uniquement en fonction des besoins.
- Réduit la surchauffe de la batterie IMPRES 2 ou IMPRES, quel que soit son temps passé dans le compartiment.
- Recharge régulièrement une batterie stockée dans le compartiment du chargeur, assurant ainsi un état de charge optimal pour l'utilisateur.
- Élimine l'effet mémoire des batteries au nickel, écartant ainsi la nécessité d'acheter des équipements spéciaux ou de former du personnel pour préserver le cycle de vie des batteries.

Grâce à ce système breveté unique, il n'est plus nécessaire de suivre et d'enregistrer l'utilisation des batteries IMPRES 2 et IMPRES, d'effectuer manuellement leur calibrage ou reconditionnement ou de les retirer des chargeurs une fois la charge terminée.

## Initialisation d'une batterie IMPRES 2 ou IMPRES

Pour bénéficier de toutes les fonctionnalités des batteries IMPRES 2 ou IMPRES, une nouvelle batterie IMPRES 2 ou IMPRES doit être initialisée par le chargeur. Le chargeur détecte automatiquement la nouvelle batterie IMPRES 2 ou IMPRES et démarre l'initialisation. L'initialisation constitue le premier calibrage/reconditionnement d'une batterie IMPRES 2 ou IMPRES. Cette procédure s'effectue en deux étapes. La première étape est la phase de décharge de la batterie, indiquée par une LED **orange fixe**. La deuxième étape consiste à la recharger entièrement et est indiquée par une LED **verte fixe**. Ce processus peut prendre jusqu'à 12 heures ou plus, selon l'état de charge et la capacité de la batterie. Si le processus est interrompu au cours de ces étapes, l'initialisation sera retardée jusqu'à la prochaine opportunité de charge.

## Compartiment à compartiment IMPRES 2 ou IMPRES

Pendant la charge des batteries IMPRES 2 ou IMPRES, le chargeur IMPRES 2 ou IMPRES enregistre des informations de charge dans la mémoire de la batterie. Si vous retirez la batterie IMPRES 2 ou IMPRES du compartiment du chargeur IMPRES 2 ou IMPRES, puis la réinsérez dans les 30 minutes dans un autre ou dans le même compartiment du chargeur IMPRES 2 ou IMPRES, la charge reprend au niveau où elle s'est interrompue. Cette fonction permet d'éviter la surcharge des batteries et de prolonger leur cycle de vie, ce qui s'avère particulièrement important avec les batteries au nickel.

## Calibrage/reconditionnement automatique d'une batterie IMPRES 2 ou IMPRES

Le chargeur IMPRES 2 évalue automatiquement la condition d'une batterie IMPRES 2 ou IMPRES, puis lance le calibrage/reconditionnement de la batterie en fonction de sa condition. Si les étapes de décharge ou de charge complète sont interrompues, le calibrage sera retardé jusqu'à la prochaine opportunité de charge.

Utilisez le mode Charger Setup pour activer ou désactiver le calibrage/reconditionnement. Si cette fonctionnalité est désactivée alors que la batterie IMPRES 2 ou IMPRES nécessite un calibrage/reconditionnement, la LED **clignote en orange et vert** lorsque vous insérez la batterie et une fois que celle-ci est chargée.

**Remarque** : la batterie IMPRES 2 ou IMPRES doit rester hors d'un compartiment du chargeur pendant plus de 30 minutes pour permettre le calibrage/reconditionnement automatique.

## Batterie IMPRES avec auto-calibrage et reconditionnement



**ATTENTION** : le calibrage/reconditionnement manuel ne s'applique pas aux batteries IMPRES ou IMPRES 2 présentant cette icône.

**Remarque :** assurez-vous que votre chargeur dispose toujours de la dernière version du micrologiciel. L'application MSI Charger Reprogrammer peut être téléchargée à partir de Motorola Online (MOL) ou du site Web Motorola Solutions.

## Mise à jour du micrologiciel

**Remarque :** s'applique à tous les appareils ou chargeurs IMPRES Gen 1 et Gen 2, qui incluent une unité d'interface de chargeur (CIU), un lecteur de données de batterie (BDR), un chargeur pour unité unique (SUC), un chargeur pour unité double (DUC) et un chargeur pour unités multiples (MUC).

Retirez toutes les batteries insérées de l'appareil ou du chargeur cible avant de mettre à niveau un appareil ou un chargeur IMPRES vers une version plus récente.

1. Connectez l'appareil ou le chargeur à votre ordinateur à l'aide d'un câble USB. L'appareil ou le chargeur connecté s'affiche dans la fenêtre principale de MSI Charger Reprogrammer.

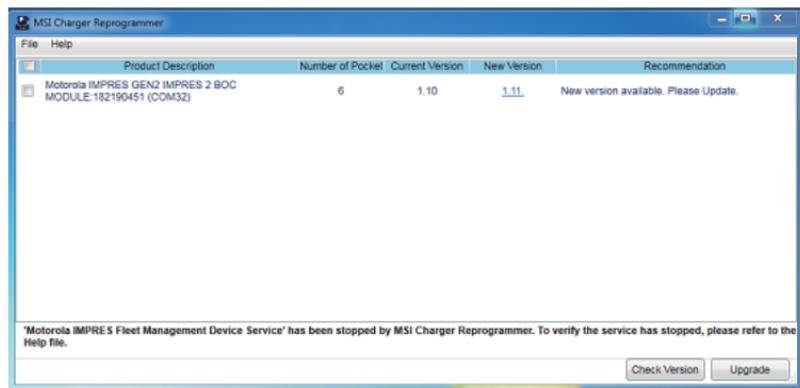



2. Cliquez sur Vérifier la version pour trouver la dernière version disponible sur le serveur MSI.

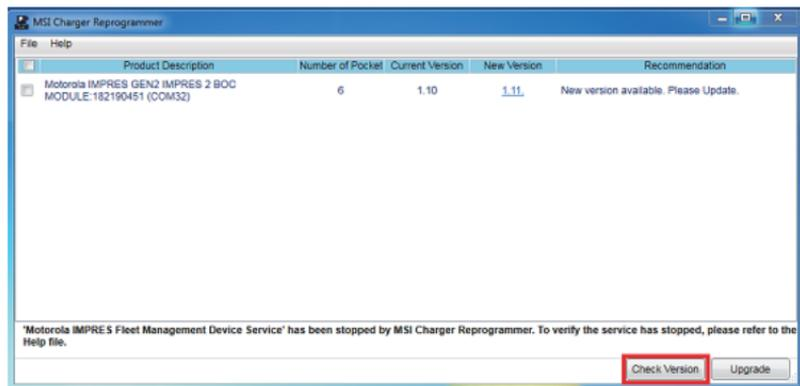

3. Sélectionnez l'appareil ou le chargeur à mettre à jour.

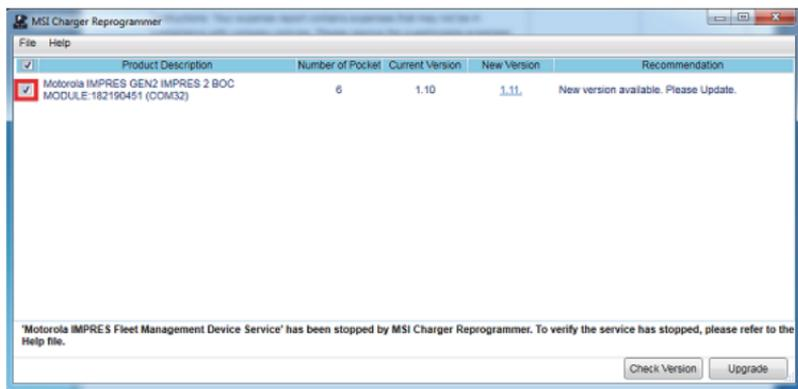

**Remarque :** vous ne pouvez pas sélectionner un appareil ou chargeur déjà mis à jour avec la dernière version du micrologiciel.

4. Pour lancer la mise à niveau du micrologiciel, cliquez sur Mettre à niveau.

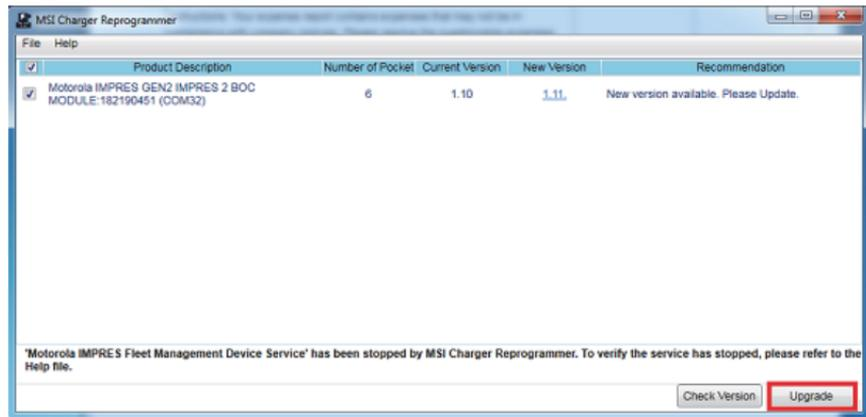

5. Cliquez sur OK dans la fenêtre de confirmation lorsque vous êtes invité à démarrer la mise à niveau. Une fenêtre indique la progression de la mise à niveau jusqu'à la fin.

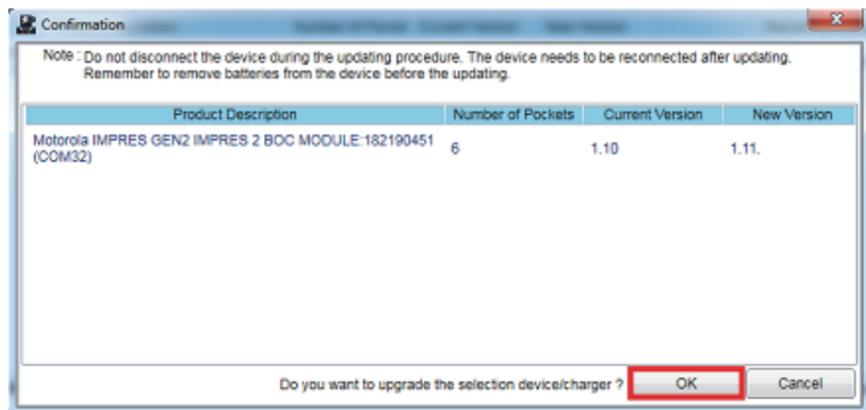

6. Fermez la fenêtre une fois toutes les mises à niveau terminées.

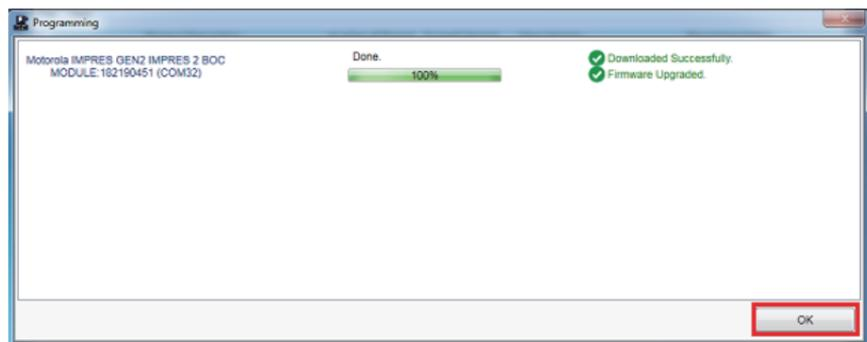

## Initialisation manuelle du calibrage/reconditionnement

Bien que le calibrage/reconditionnement soit automatique, il se peut que, dans certaines conditions, une initialisation manuelle soit préférable. Par exemple, le chargeur peut **clignoter en orange et vert** pour la batterie IMPRES 2 ou IMPRES lorsque le calibrage est désactivé sur le chargeur. Si, dans les 30 minutes, cette batterie est placée sur un chargeur sur lequel le calibrage est activé, le dernier état de charge reprend, ce qui empêche le démarrage automatique du calibrage/reconditionnement.

Pour initialiser manuellement le calibrage/reconditionnement, retirez la batterie IMPRES 2 ou IMPRES du chargeur pendant plus de 2 minutes 30. Procédez ensuite comme suit :

1. Insérez la batterie dans le compartiment du chargeur.
2. Dans les 2 minutes 30 qui suivent, retirez la batterie du compartiment du chargeur.
3. Dans les 5 secondes qui suivent, réinsérez la batterie dans le compartiment du chargeur.

Le calibrage/reconditionnement démarre immédiatement, en commençant généralement par la phase de décharge de la batterie (**orange fixe**). Le calibrage/reconditionnement se termine une fois la batterie entièrement chargée (**vert fixe**).

## Arrêt manuel du calibrage/reconditionnement

Vous pouvez interrompre le calibrage/reconditionnement à tout moment pendant le processus de décharge de la batterie IMPRES 2 ou IMPRES (orange fixe) en procédant comme suit :

1. Retirez la batterie du compartiment du chargeur.
2. Dans les 5 secondes qui suivent, réinsérez la batterie dans le compartiment du chargeur.

Le processus de décharge de la batterie se termine immédiatement et la charge normale de la batterie commence. La LED indique l'état de la charge.

## Présentation du chargeur

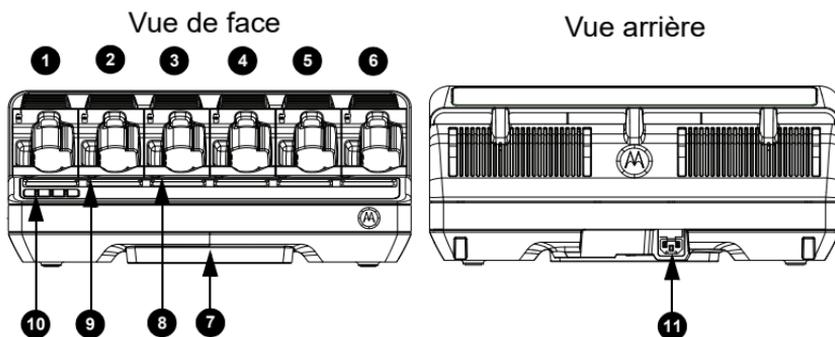

Figure 1 : Présentation du chargeur

Tableau 5 : Présentation et description du chargeur

N°	Nom	Description
1-6	Compartiments de charge	Chaque compartiment peut accueillir une radio ou une batterie autonome compatible
7	Module de communication	Dans certains chargeurs, le module de communication permet également de recharger vos accessoires USB : <ul style="list-style-type: none"><li>• UE/RU PS000029A03</li><li>• KR PS000029A08</li></ul>
8	Indicateur d'état lumineux du compartiment	LED d'état de charge (une par compartiment)
9	Écran	Écran facultatif pour les compartiments autres que le compartiment 1

**Tableau 5 : Présentation et description du chargeur (Suite)**

N°	Nom	Description
10	Écran du clavier	Écran du compartiment 1 avec clavier de menu
11	Connecteur d'entrée CA	Utilise le cordon d'alimentation spécifique au pays ou à la région

## **Indication de fin de cycle de vie IMPRES 2 ou IMPRES**

Le chargeur peut indiquer la fin du cycle de vie d'une batterie IMPRES 2 or IMPRES (**clignotement rouge et vert**) une fois le calibrage/reconditionnement de la batterie terminé.

Au fur et à mesure de l'utilisation des batteries, l'usure normale réduit leur capacité. Une fois le calibrage/reconditionnement terminé, le chargeur compare la capacité des batteries IMPRES 2 ou IMPRES par rapport à leur capacité nominale. Lorsque le niveau de capacité de la batterie IMPRES 2 ou IMPRES est très faible, cela peut signifier qu'elle se rapproche de la fin de son cycle de vie. La batterie IMPRES 2 ou IMPRES reste utilisable. Dans certains cas, il peut être souhaitable de transférer la batterie à un collègue n'ayant pas besoin d'une grande capacité de batterie pour sa journée de travail entière.

La batterie APX NEXT XN est dotée d'une fonction de détection de température élevée qui est détectable par le chargeur IMPRES 2 avec la version logicielle V2.05 ou version ultérieure. Lorsque cette fonction est activée, la LED d'état clignote alternativement en rouge et vert à la fin de la charge d'une batterie étant restée trop longtemps dans un environnement à température extrêmement élevée. Le chargeur affiche les informations suivantes :

REPLACE BATTERY  
EXPOSED OVERTEMP

Il est recommandé de mettre cette batterie hors service.

## **Chargement des batteries ou des radios avec batterie**

Les performances de charge sont meilleures à température ambiante. Les chargeurs pour unités multiples IMPRES 2 peuvent charger une batterie autonome ou une batterie installée sur une radio.

1. Placez le chargeur sur une surface plane.

2. Insérez fermement le cordon d'alimentation dans le connecteur d'entrée secteur situé à l'arrière du chargeur.
3. Branchez le cordon d'alimentation sur une prise d'alimentation appropriée.
4. Une fois le chargeur mis sous tension, chaque LED d'état de charge clignote en **vert** pendant environ une seconde et le message `IMPRES 2 CHARGER` s'affiche. Si les LED d'état de charge ne clignotent pas et qu'aucun message ne s'affiche, vérifiez les branchements du cordon d'alimentation.
5. Insérez une radio avec sa batterie ou une batterie autonome dans un compartiment libre.

**Remarque :** tenez fermement le corps de la radio lorsque vous l'insérez dans le chargeur ou que vous l'en retirez. Évitez de tirer sur l'antenne de la radio.

6. Une fois que la radio ou la batterie autonome est correctement positionnée dans le compartiment, l'état de charge est indiqué par la LED d'état de charge correspondante. L'écran associé fournit des informations supplémentaires. Pour les chargeurs à un seul écran, seul l'état de charge du compartiment 1 est indiqué.
7. La batterie est prête à être utilisée lorsque l'état de charge est **vert fixe**.
8. Allumez la radio uniquement lorsque le module de communication du chargeur est détaché du PC. Dans le cas contraire, mettez l'appareil ou la radio hors tension.

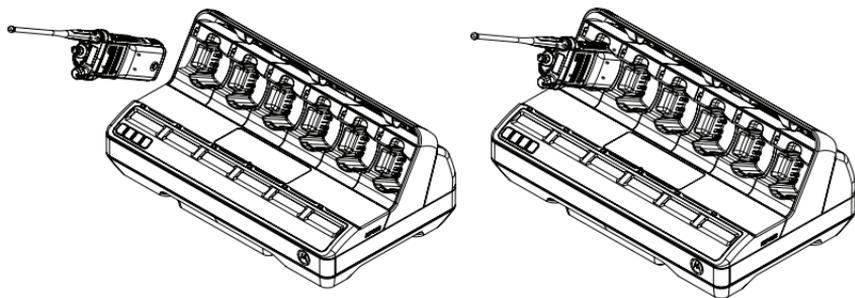

**Figure 2 :** Chargement d'une batterie connectée à une radio

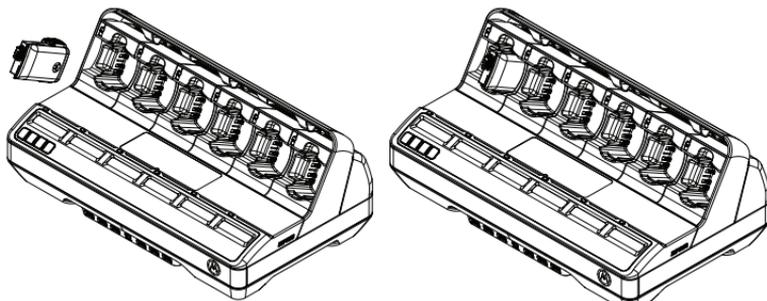

Figure 3 : Batterie autonome en charge

## Chargement d'accessoires USB

Certains modules de communication de chargeur pour unités multiples IMPRES 2 fournissent des embases USB Type-A pour charger des accessoires USB. Les performances de charge des accessoires USB sont meilleures à température ambiante.

1. Placez le chargeur adaptatif IMPRES 2 sur une surface plane.
2. Insérez fermement le cordon d'alimentation dans la prise CA située à l'arrière du chargeur.
3. Branchez le cordon d'alimentation sur une prise d'alimentation appropriée.
4. Une fois le chargeur mis sous tension, la LED d'état de chaque compartiment clignote en **vert** pendant une seconde et le message **IMPRES 2 CHARGER** s'affiche. Si les LED d'état ne s'allument pas et si aucun message ne s'affiche, vérifiez les connexions du cordon d'alimentation.
5. Certains accessoires USB disposent d'un réceptacle de charge Micro-AB. Utilisez un câble USB standard de 1 mètre maximum dont l'une des extrémités présente une fiche de type A et l'autre extrémité une fiche compatible avec l'accessoire (généralement Micro-B ou Micro-AB).
6. Alignez correctement la fiche de type A du câble USB avec un port de type A sur le module de communication. Insérez la fiche dans le port.
7. Alignez correctement la fiche Micro-B du câble USB avec le réceptacle Micro-AB sur l'accessoire USB. Insérez la fiche dans le réceptacle.
8. Une fois les connexions USB correctement effectuées, l'état de charge est indiqué par l'accessoire USB. Reportez-vous au Guide de l'utilisateur de l'accessoire USB pour plus d'informations.

## Indications de charge

**Tableau 6 :** Indications de charge pour les batteries IMPRES 2 ou IMPRES - Calibrage non requis

État	Écran du compartiment	Indicateur LED
Mise sous tension du chargeur	IMPRES 2 CHARGER	Vert pendant environ une seconde 
Batterie détectée	IMPRES 2 BATTERY OU IMPRES BATTERY	Rouge fixe 
Charge rapide	RAPID CHARGE XXXX0mAh yyy%Pt1	Rouge fixe 
Batterie chargée à 90 % ou plus	TRICKLE CHARGE xxxx0mAh yyy%Pt1	Vert clignotant 
Batterie chargée à 95 % ou plus	CHARGE COMPLETE xxxx0mAh yyy%Pt1	Vert fixe 
Panne	AVERTISSEMENT : NOT CHARGEABLE REMOVE & REINSERT	Rouge clignotant 
Veille <ul style="list-style-type: none"> <li>• Batterie en attente de charge rapide.</li> <li>• Batterie trop chaude, trop froide ou basse tension.</li> <li>• Chargeur trop chaud.</li> </ul>	AVERTISSEMENT : HOT BATTERY WAITING TO CHARGE OU COLD BATTERY WAITING TO CHARGE OU VERY LOW BATTERY WAITING TO CHARGE OU HOT CHARGER WAITING TO CHARGE	Orange clignotant 

### Remarque :

- Le message `Hot Charger` (Chargeur chaud) a été introduit dans la version 1.05 du logiciel.
- Les indications de pourcentage de l'état du chargeur comparant la capacité potentielle à la capacité nominale ont été introduites dans la version 1.11.01 du logiciel.



**Tableau 7 : Indications de charge pour le calibrage des batteries IMPRES 2 ou IMPRES - Calibrage activé**

État	Écran du compartiment	Indicateur LED
Mise sous tension du chargeur	IMPRES 2 CHARGER	Vert pendant environ une seconde 
Batterie détectée	IMPRES 2 BATTERY OU IMPRES BATTERY	Orange fixe 
Décharge de la batterie	CAL DISCHARGE xxxxx0mAh yyyzPt1	Orange fixe 
Charge rapide	CAL RAPID CHARGE xxxxx0mAh yyyzPt1	Rouge fixe 
Batterie chargée à 90 % ou plus	CAL TRICKLE CHARGE xxxxx0mAh yyyzPt1	Vert clignotant 
Batterie chargée à 95 % ou plus	CHARGE COMPLETE xxxxx0mAh yyyzPt1	Calibrage de la batterie terminé : Vert fixe 
	REPLACE BATTERY EXPOSED OVERTEMP	Calibrage de la batterie terminé, mais la batterie se rapproche peut-être de la fin de son cycle de vie (batterie utilisable) : Rouge/vert clignotant 
Panne	AVERTISSEMENT : NOT CHARGEABLE REMOVE & REINSERT	Rouge clignotant 

**Tableau 7 :** Indications de charge pour le calibrage des batteries IMPRES 2 ou IMPRES - Calibrage activé (Suite)

État	Écran du compartiment	Indicateur LED
<p>Veille</p> <ul style="list-style-type: none"> <li>• Batterie en attente de charge rapide.</li> <li>• Batterie trop chaude, trop froide ou basse tension.</li> <li>• Chargeur trop chaud.</li> </ul>	<p>AVERTISSEMENT : HOT BATTERY WAITING TO CAL OU COLD BATTERY WAITING TO CAL OU VERY LOW BATTERY WAITING TO CHARGE OU HOT CHARGER WAITING TO CAL</p>	<p>Orange clignotant</p> 

**Tableau 8** : Indications de charge pour le calibrage des batteries IMPRES 2 ou IMPRES - Calibrage désactivé à l'origine, puis activé

État	Écran du chargeur	Indicateur LED
Mise sous tension du chargeur	IMPRES 2 CHARGER	Vert pendant environ une seconde 
Batterie détectée	IMPRES 2 BATTERY ou IMPRES BATTERY	La batterie nécessite un calibrage, mais le calibrage est désactivé sur le chargeur : Alternance orange/vert pendant 4 secondes 
Demande de calibrage de la batterie IMPRES • Calibrage désactivé dans le chargeur • Batterie en chargement	AVERTISSEMENT : ENABLE BATTERY CALIBRATION? • Appuyer sur OK pour activer le calibrage • Ignorer pour lancer la charge normale (le message disparaît au bout d'une minute)	Rouge fixe 
Décharge de la batterie • OK sélectionné	CAL DISCHARGE xxxx@mAh yy%zP t1	Orange fixe 
Charge rapide	CAL RAPID CHARGE xxxx@mAh yy%zP t1	Rouge fixe 
Batterie chargée à 90 % ou plus	CAL TRICKLE CHARGE xxxx@mAh yy%zP t1	Vert clignotant 

**Tableau 8 :** Indications de charge pour le calibrage des batteries IMPRES 2 ou IMPRES - Calibrage désactivé à l'origine, puis activé (Suite)

État	Écran du chargeur	Indicateur LED
Batterie chargée à 95 % ou plus	<p>CHARGE COMPLETE xxxx@mAh yy%zP t1</p>	<p>Calibrage de la batterie terminé : Vert fixe </p> <p>Calibrage de la batterie terminé, mais la batterie se rapproche peut-être de la fin de son cycle de vie (batterie utilisable) : Rouge/vert clignotant </p>
	<p>REPLACE BATTERY EXPOSED OVERTEMP</p>	<p>Calibrage de la batterie terminé, mais la batterie a été exposée à une température trop élevée (il est conseillé de la mettre hors service) : Rouge/vert clignotant REMARQUE : applicable uniquement à la batterie APX NEXT XN </p>
Panne	<p>AVERTISSEMENT : NOT CHARGEABLE REMOVE &amp; REINSERT</p>	<p>Rouge clignotant </p>
<p>Veille</p> <ul style="list-style-type: none"> <li>• Batterie en attente de charge rapide.</li> <li>• Batterie trop chaude, trop froide ou basse tension.</li> <li>• Chargeur trop chaud.</li> </ul>	<p>AVERTISSEMENT : HOT BATTERY WAITING TO CAL OU COLD BATTERY WAITING TO CAL OU VERY LOW BATTERY WAITING TO CHARGE OU HOT CHARGER WAITING TO CAL</p>	<p>Orange clignotant </p>

**Tableau 9 : Indications de charge pour les batteries IMPRES 2 ou IMPRES - Calibrage requis, mais non activé**

État	Écran du chargeur	Indicateur LED
Mise sous tension du chargeur	IMPRES 2 CHARGER	Vert pendant environ une seconde 
Batterie détectée	IMPRES 2 BATTERY ou IMPRES BATTERY	La batterie nécessite un calibrage, mais le calibrage est désactivé sur le chargeur : Alternance orange/vert pendant 4 secondes 
Demande de calibrage de la batterie IMPRES <ul style="list-style-type: none"> <li>• Calibrage désactivé dans le chargeur.</li> <li>• La batterie est en cours de chargement.</li> </ul>	AVERTISSEMENT : ENABLE BATTERY CALIBRATION?  <ul style="list-style-type: none"> <li>• Appuyer sur OK pour activer le calibrage</li> <li>• Ignorer pour lancer la charge normale (le message disparaît au bout d'une minute)</li> </ul>	Rouge fixe 
Charge rapide <ul style="list-style-type: none"> <li>• Délai de demande de calibrage dépassé.</li> </ul>	RAPID CHARGE xxxxx@mAh yyy%P t1	Rouge fixe 
Batterie chargée à 90 % ou plus	TRICKLE CHARGE xxxxx@mAh yyy%P t1	Vert clignotant 
Batterie chargée à 95 % ou plus	CHARGE COMPLETE xxxxx@mAh yyy%P t1	Alternance orange/vert 
Panne	AVERTISSEMENT : NOT CHARGEABLE REMOVE & REINSERT	Rouge clignotant 
Veille <ul style="list-style-type: none"> <li>• Batterie en attente de charge rapide.</li> <li>• Batterie trop chaude, trop froide ou basse tension.</li> <li>• Chargeur trop chaud.</li> </ul>	AVERTISSEMENT : HOT BATTERY WAITING TO CHARGE OU COLD BATTERY WAITING TO CHARGE OU VERY LOW BATTERY WAITING TO CHARGE OU HOT CHARGER WAITING TO CHARGE	Orange clignotant 

**Tableau 10** : Indications de charge pour les batteries IMPRES 2 ou IMPRES entièrement chargées - Calibrage requis, mais non activé

État	Écran du chargeur	Indicateur LED
Mise sous tension du chargeur	IMPRES 2 CHARGER	Vert pendant environ une seconde 
Batterie détectée	IMPRES 2 BATTERY ou IMPRES BATTERY	La batterie requiert un calibrage, mais a été entièrement chargée dans les 30 dernières minutes et le calibrage est désactivé dans le chargeur : Alternance orange/vert 
Panne	AVERTISSEMENT : NOT CHARGEABLE REMOVE & REINSERT	Rouge clignotant 
Veille • Batterie en attente de charge rapide. • Batterie trop chaude, trop froide ou basse tension. • Chargeur trop chaud.	AVERTISSEMENT : HOT BATTERY WAITING TO CHARGE OU COLD BATTERY WAITING TO CHARGE OU VERY LOW BATTERY WAITING TO CHARGE OU HOT CHARGER WAITING TO CHARGE	Orange clignotant 

## Autres batteries Motorola Solutions

**Tableau 11** : Indications de charge pour les autres batteries de Motorola Solutions

État	Écran du chargeur	Indicateur LED
Mise sous tension du chargeur	IMPRES 2 CHARGER	Vert pendant environ une seconde 
Batterie détectée	MOTOROLA SOLUTIONS BATTERY	Rouge fixe 
Charge rapide	RAPID CHARGE	Rouge fixe 
Batterie chargée à 90 % ou plus	TRICKLE CHARGE	Vert clignotant 
Batterie chargée à 95 % ou plus	CHARGE COMPLETE	Vert fixe 
Panne	AVERTISSEMENT : NOT CHARGEABLE REMOVE & REINSERT	Rouge clignotant 
Veille <ul style="list-style-type: none"> <li>• Batterie en attente de charge rapide.</li> <li>• Batterie trop chaude, trop froide ou basse tension.</li> <li>• Chargeur trop chaud.</li> </ul>	AVERTISSEMENT : HOT BATTERY WAITING TO CHARGE OU COLD BATTERY WAITING TO CHARGE OU VERY LOW BATTERY WAITING TO CHARGE OU HOT CHARGER WAITING TO CHARGE	Orange clignotant 

## Batterie inconnue

Il se peut que le chargeur ne détecte pas certaines batteries inconnues. Les batteries inconnues ne déclarent pas leurs paramètres de charge d'une manière reconnaissable par le chargeur. Si une batterie inconnue est détectée, le chargeur indique l'état de charge comme indiqué dans le Tableau 12.

**Tableau 12** : Indications de charge des batteries inconnues

État	Écran du chargeur	Indicateur LED
Mise sous tension du chargeur	IMPRES 2 CHARGER	Vert pendant environ une seconde 
Batterie détectée	UNKNOWN BATTERY	Rouge fixe 
Charge rapide	RAPID CHARGE	Rouge fixe 
Batterie presque chargée • Capacité de la batterie inconnue	TRICKLE CHARGE	Vert clignotant 
Chargée • Capacité de la batterie inconnue	CHARGE COMPLETE	Vert fixe 
Panne	AVERTISSEMENT : HOT CHARGEABLE REMOVE & REINSERT	Rouge clignotant 
Veille • Batterie en attente de charge rapide. • Batterie trop chaude, trop froide ou basse tension. • Chargeur trop chaud.	AVERTISSEMENT : HOT BATTERY WAITING TO CHARGE OU COLD BATTERY WAITING TO CHARGE OU VERY LOW BATTERY WAITING TO CHARGE OU HOT CHARGER WAITING TO CHARGE	Orange clignotant 



## Stockage à long terme des batteries IMPRES 2 ou IMPRES

Vous pouvez préparer les batteries IMPRES 2 ou IMPRES Motorola Solutions autonomes authentiques (lithium-ion ou nickel) pour le stockage à long terme dans un lieu de stockage adapté à l'aide d'un chargeur pour unités multiples IMPRES 2. Les autres types de batteries engendrent une erreur. Si la batterie IMPRES 2 est dotée d'un mode Sleep (Veille), le chargeur met la batterie en veille à la fin de la charge pour stockage à long terme.

Préparez uniquement des batteries IMPRES 2 ou IMPRES pour le stockage à long terme. Retirez la batterie de la radio avant de la placer dans le chargeur.

NE STOCKEZ PAS une batterie autonome dans le chargeur. Lorsque la préparation pour le stockage à long terme est terminée, retirez immédiatement la batterie autonome du chargeur.

La sélection du stockage à long terme prévaut sur le calibrage/reconditionnement. Les batteries au lithium préparées pour le stockage à long terme peuvent ne pas satisfaire les exigences liées au transport par fret aérien.

**Tableau 13** : Indications de stockage à long terme d'une batterie IMPRES 2 ou IMPRES - Batterie devant être calibrée

État	Écran du chargeur	Indicateur LED
Mise sous tension du chargeur	IMPRES 2 CHARGER	Vert pendant environ une seconde 
Batterie détectée	IMPRES 2 BATTERY ou IMPRES BATTERY	La batterie nécessite un calibrage : Alternance orange/vert pendant 4 secondes 
Décharge de la batterie	STORAGE DISCHARGE xxxx% Rated Cap	Orange fixe 
Charge rapide	STORAGE CHARGE xxx% Rated Cap	Rouge fixe 
Stockage à long terme terminé	LONGTERM STORAGE xxx% Rated Cap	Alternance orange/vert 

**Tableau 13** : Indications de stockage à long terme d'une batterie IMPRES 2 ou IMPRES - Batterie devant être calibrée (Suite)

État	Écran du chargeur	Indicateur LED
<p>Panne</p> <ul style="list-style-type: none"> <li>Le contact électrique entre la batterie et le chargeur ne s'effectue pas correctement.</li> <li>La batterie n'est pas une batterie IMPRES 2 ou IMPRES.</li> <li>Une condition inconnue empêche la batterie d'être déchargée.</li> <li>Le chargement est terminé avant que l'objectif de stockage à long terme soit atteint.</li> <li>Le compartiment de charge est d'un type spécial.</li> </ul>	<p>AVERTISSEMENT :</p> <p>HOT CHARGEABLE REMOVE &amp; REINSERT OU</p> <p>WRONG BATT TYPE CANNOT LT STORE OU</p> <p>CANNOT DISCHARGE FOR LT STORAGE OU</p> <p>STORE INCOMPLETE Low Capacity:yy%</p> <p>OU</p> <p>RADIO POCKET CANNOT LT STORE OU</p> <p>CHARGING POCKET CANNOT LT STORE</p>	<p>Rouge clignotant</p> 
<p>Veille</p> <ul style="list-style-type: none"> <li>Batterie en attente de charge rapide.</li> <li>Batterie trop chaude, trop froide ou basse tension.</li> <li>Chargeur trop chaud.</li> </ul>	<p>AVERTISSEMENT :</p> <p>HOT BATTERY WAITING TO CHRGE OU</p> <p>COLD BATTERY WAITING TO CHRGE OU</p> <p>VERY LOW BATTERY WAITING TO CHRGE OU</p> <p>HOT CHARGER WAITING TO CHRGE</p>	<p>Orange clignotant</p> 

**Remarque :**

- Les messages suivants ont été introduits dans la version logicielle 1.05 :
  - Cannot Discharge, for LT Storage
  - Store Incomplete, Low Capacity:yy%
  - Hot Charger, Waiting to Chrge
- Les messages suivants ont été introduits dans la version logicielle 1.11.01 :
  - Wrong Batt Type, Cannot LT Store
  - Radio Pocket, Cannot LT Store
  - Charging Pocket, Cannot LT Store

**Tableau 14** : Indications de stockage à long terme d'une batterie IMPRES 2 ou IMPRES - Batterie calibrée, doit se recharger jusqu'au niveau sélectionné

État	Écran du chargeur	Indicateur LED
Mise sous tension du chargeur	IMPRES 2 CHARGER	Vert pendant environ une seconde 
Batterie détectée	IMPRES 2 BATTERY ou IMPRES BATTERY	Rouge fixe 
Charge rapide	STORAGE CHARGE xxx% Rated Cap	Rouge fixe 
Stockage à long terme terminé	LONGTERM STORAGE xxx% Rated Cap	Vert fixe 
<b>Panne</b> <ul style="list-style-type: none"> <li>Le contact électrique entre la batterie et le chargeur ne s'effectue pas correctement.</li> <li>La batterie n'est pas une batterie IMPRES 2 ou IMPRES.</li> <li>Une condition inconnue empêche la batterie d'être déchargée.</li> <li>Le chargement est terminé avant que l'objectif de stockage à long terme soit atteint.</li> <li>Le compartiment de charge est d'un type spécial.</li> </ul>	AVERTISSEMENT : NOT CHARGEABLE REMOVE & REINSERT OU WRONG BATT TYPE CANNOT LT STORE OU CANNOT DISCHARGE FOR LT STORAGE OU STORE INCOMPLETE Low Capacity:yy% OU RADIO POCKET CANNOT LT STORE OU CHARGING POCKET CANNOT LT STORE	Rouge clignotant 
<b>Veille</b> <ul style="list-style-type: none"> <li>Batterie en attente de charge rapide.</li> <li>Batterie trop chaude, trop froide ou basse tension.</li> <li>Chargeur trop chaud.</li> </ul>	AVERTISSEMENT : HOT BATTERY WAITING TO CHRG OU COLD BATTERY WAITING TO CHRG OU VERY LOW BATTERY WAITING TO CHRG OU HOT CHARGER WAITING TO CHRG	Orange clignotant 

**Tableau 15** : Indications de stockage à long terme d'une batterie IMPRES 2 ou IMPRES - Batterie calibrée, doit se décharger jusqu'au niveau sélectionné

État	Écran du chargeur	Indicateur LED
Mise sous tension du chargeur	IMPRES 2 CHARGER	Vert pendant environ une seconde 
Batterie détectée	IMPRES 2 BATTERY ou IMPRES BATTERY	Orange fixe 
Décharge de la batterie	STORAGE DISCHARGE xxx% Rated Cap	Orange fixe 
Stockage à long terme terminé	LONGTERM STORAGE xxx% Rated Cap	Vert fixe 
<b>Panne</b> <ul style="list-style-type: none"> <li>Le contact électrique entre la batterie et le chargeur ne s'effectue pas correctement.</li> <li>La batterie n'est pas une batterie IMPRES 2 ou IMPRES.</li> <li>Une condition inconnue empêche la batterie d'être déchargée.</li> <li>Le chargement est terminé avant que l'objectif de stockage à long terme soit atteint.</li> <li>Le compartiment de charge est d'un type spécial.</li> </ul>	AVERTISSEMENT : NOT CHARGEABLE REMOVE & REINSERT OU WRONG BATT TYPE CANNOT LT STORE OU CANNOT DISCHARGE FOR LT STORAGE OU STORE INCOMPLETE Low Capacity:yy% OU RADIO POCKET CANNOT LT STORE OU CHARGING POCKET CANNOT LT STORE	Rouge clignotant 
<b>Veille</b> <ul style="list-style-type: none"> <li>Batterie en attente de charge rapide.</li> <li>Batterie trop chaude, trop froide ou basse tension.</li> <li>Chargeur trop chaud.</li> </ul>	AVERTISSEMENT : HOT BATTERY WAITING TO CHARGE OU COLD BATTERY WAITING TO CHARGE OU VERY LOW BATTERY WAITING TO CHARGE OU HOT CHARGER WAITING TO CHARGE	Orange clignotant 

## Préparation d'une batterie au lithium-ion pour expédition

Vous pouvez préparer les batteries autonomes IMPRES 2, IMPRES et autres batteries au lithium Motorola Solutions authentiques pour le transport par fret aérien à l'aide d'un chargeur pour unités multiples IMPRES 2. Les autres types de batteries engendrent une erreur. Si la batterie IMPRES 2 au lithium-ion est dotée d'un mode Sleep (Veille), le chargeur met la batterie en veille à la fin du processus de charge Ship Lithium.

Préparez uniquement les batteries au lithium-ion Motorola Solutions autonomes pour l'expédition. Retirez la batterie de la radio avant de la placer dans le chargeur.

NE STOCKEZ PAS une batterie autonome dans le chargeur. Lorsque la préparation pour l'expédition est terminée, retirez immédiatement la batterie autonome du chargeur.

La sélection de l'expédition de batteries au lithium prévaut sur le calibrage/reconditionnement.

### Batterie IMPRES 2 ou IMPRES

**Tableau 16 :** Indications d'état d'une batterie au lithium-ion préparée pour l'expédition - Batterie IMPRES 2 ou IMPRES devant être calibrée

État	Écran du chargeur	Indicateur LED
Mise sous tension du chargeur	IMPRES 2 CHARGER	Vert pendant environ une seconde 
Batterie détectée	IMPRES 2 BATTERY ou IMPRES BATTERY	La batterie nécessite un calibrage : Alternance orange/vert pendant 4 secondes  
Décharge de la batterie	SHIP LI DISCHRG xxx% Rated Cap	Orange fixe 
Charge rapide	SHIP LI CHARGE xxx% Rated Cap	Rouge fixe 
Ship Lithium terminé	LI READY TO SHIP xxx% Rated Cap	Alternance orange/vert  

**Tableau 16** : Indications d'état d'une batterie au lithium-ion préparée pour l'expédition - Batterie IMPRES 2 ou IMPRES devant être calibrée (Suite)

État	Écran du chargeur	Indicateur LED
<p>Panne</p> <ul style="list-style-type: none"> <li>Le contact électrique entre la batterie et le chargeur ne s'effectue pas correctement.</li> <li>Batterie inconnue ou batterie nickel.</li> <li>Une condition inconnue empêche la batterie d'être déchargée.</li> <li>Le chargement est terminé avant que l'objectif Ship Lithium soit atteint.</li> <li>Le compartiment de charge est d'un type spécial.</li> </ul>	<p>AVERTISSEMENT : NOT CHARGEABLE REMOVE &amp; REINSERT OU WRONG BATT TYPE CANNOT SHIP LI OU CANNOT DISCHARGE FOR LI SHIPMENT OU SHIP INCOMPLETE Low Capacity:yy% OU RADIO POCKET CANNOT SHIP LI OU CHARGING POCKET CANNOT SHIP LI</p>	<p>Rouge clignotant</p> 
<p>Veille</p> <ul style="list-style-type: none"> <li>Batterie en attente de charge rapide.</li> <li>Batterie trop chaude, trop froide ou basse tension.</li> <li>Chargeur trop chaud.</li> </ul>	<p>AVERTISSEMENT : HOT BATTERY WAITING TO CHARGE OU COLD BATTERY WAITING TO CHARGE OU VERY LOW BATTERY WAITING TO CHARGE OU HOT CHARGER WAITING TO CHARGE</p>	<p>Orange clignotant</p> 

**Remarque :**

- Les messages suivants ont été introduits dans la version logicielle 1.05 :
  - Ship LI Discharge, xxx% Rated Capacity
  - Ship LI Charge, xxx% Rated Capacity
  - LI Ready to Ship, xx% Rated Capacity
  - Cannot Discharge, for LI Shipment
  - Ship Incomplete, Low Capacity:yy%
- Les messages suivants ont été introduits dans la version logicielle 1.11.01 :
  - Wrong Batt Type, Cannot Ship LI
  - Radio Pocket, Cannot Ship LI
  - Charging Pocket, Cannot Ship LI

**Tableau 17 :** Indications d'état d'une batterie au lithium-ion préparée pour l'expédition - Batterie IMPRES ou IMPRES 2 calibrée, doit être chargée

État	Écran du chargeur	Indicateur LED
Mise sous tension du chargeur	IMPRES 2 CHARGER	Vert pendant environ une seconde 
Batterie détectée	IMPRES 2 BATTERY ou IMPRES BATTERY	Rouge fixe 
Charge rapide	SHIP LI CHARGE xxx% Rated Cap	Rouge fixe 
Ship Lithium terminé	LI READY TO SHIP xxx% Rated Cap	Vert fixe 
<p>Panne</p> <ul style="list-style-type: none"> <li>Le contact électrique entre la batterie et le chargeur ne s'effectue pas correctement.</li> <li>Batterie inconnue ou batterie nickel.</li> <li>Une condition inconnue empêche la batterie d'être déchargée.</li> <li>Le chargement est terminé avant que l'objectif Ship Lithium soit atteint.</li> <li>Le compartiment de charge est d'un type spécial.</li> </ul>	<p>AVERTISSEMENT :</p> <p>HOT CHARGEABLE REMOVE &amp; REINSERT OU WRONG BATT TYPE CANNOT SHIP LI OU CANNOT DISCHARGE FOR LI SHIPMENT OU SHIP INCOMPLETE Low Capacity:yy% OU RADIO POCKET CANNOT SHIP LI OU CHARGING POCKET CANNOT SHIP LI</p>	Rouge clignotant 
<p>Veille</p> <ul style="list-style-type: none"> <li>Batterie en attente de charge rapide.</li> <li>Batterie trop chaude, trop froide ou basse tension.</li> <li>Chargeur trop chaud.</li> </ul>	<p>AVERTISSEMENT :</p> <p>HOT BATTERY WAITING TO CHARGE OU COLD BATTERY WAITING TO CHARGE OU VERY LOW BATTERY WAITING TO CHARGE OU HOT CHARGER WAITING TO CHARGE</p>	Orange clignotant 

**Tableau 18 :** Indications d'état d'une batterie au lithium-ion préparée pour l'expédition - Batterie IMPRES ou IMPRES 2 calibrée, doit être déchargée

État	Écran du chargeur	Indicateur LED
Mise sous tension du chargeur	IMPRES 2 CHARGER	Vert pendant environ une seconde 
Batterie détectée	IMPRES 2 BATTERY ou IMPRES BATTERY	Orange fixe 
Décharge de la batterie	SHIP LI DISCHARGE xxx% Rated Cap	Orange fixe 
Ship Lithium terminé	LI READY TO SHIP xxx% Rated Cap	Vert fixe 
<p>Panne</p> <ul style="list-style-type: none"> <li>Le contact électrique entre la batterie et le chargeur ne s'effectue pas correctement.</li> <li>Batterie inconnue ou batterie nickel.</li> <li>Une condition inconnue empêche la batterie d'être déchargée.</li> <li>Le chargement est terminé avant que l'objectif Ship Lithium soit atteint.</li> <li>Le compartiment de charge est d'un type spécial.</li> </ul>	<p>AVERTISSEMENT :</p> <p>HOT CHARGEABLE REMOVE &amp; REINSERT OU WRONG BATT TYPE CANNOT SHIP LI OU CANNOT DISCHARGE FOR LI SHIPMENT OU SHIP INCOMPLETE Low Capacity:yy% OU RADIO POCKET CANNOT SHIP LI OU CHARGING POCKET CANNOT SHIP LI</p>	<p>Rouge clignotant </p>
<p>Veille</p> <ul style="list-style-type: none"> <li>Batterie en attente de charge rapide.</li> <li>Batterie trop chaude, trop froide ou basse tension.</li> <li>Chargeur trop chaud.</li> </ul>	<p>AVERTISSEMENT :</p> <p>HOT BATTERY WAITING TO CHARGE OU COLD BATTERY WAITING TO CHARGE OU VERY LOW BATTERY WAITING TO CHARGE OU HOT CHARGER WAITING TO CHARGE</p>	<p>Orange clignotant </p>



## Autres batteries Motorola Solutions

**Tableau 19 :** Indications d'état d'une batterie au lithium-ion préparée pour l'expédition - Autre batterie Motorola Solutions

État	Écran du chargeur	Indicateur LED
Mise sous tension du chargeur	IMPRES 2 CHARGER	Vert pendant environ une seconde 
Batterie détectée	MOTOROLA SOLUTIONS BATTERY	Orange fixe 
Décharge de la batterie	SHIP LI DISCHARGE xxx% Rated Cap	Orange fixe 
Charge rapide	SHIP LI CHARGE xxx% Rated Cap	Rouge fixe 
Ship Lithium terminé	LI READY TO SHIP xxx% Rated Cap	Vert fixe 
<p>Panne</p> <ul style="list-style-type: none"> <li>Le contact électrique entre la batterie et le chargeur ne s'effectue pas correctement.</li> <li>Batterie inconnue ou batterie nickel.</li> <li>Une condition inconnue empêche la batterie d'être déchargée.</li> <li>Le chargement est terminé avant que l'objectif Ship Lithium soit atteint.</li> <li>Le compartiment de charge est d'un type spécial.</li> </ul>	<p>AVERTISSEMENT :</p> <p>HOT CHARGEABLE REMOVE &amp; REINSERT OU WRONG BATT TYPE CANNOT SHIP LI OU CANNOT DISCHARGE FOR LI SHIPMENT OU SHIP INCOMPLETE Low Capacity:yy% OU RADIO POCKET CANNOT SHIP LI OU CHARGING POCKET CANNOT SHIP LI</p>	<p>Rouge clignotant</p> 
<p>Veille</p> <ul style="list-style-type: none"> <li>Batterie en attente de charge rapide.</li> <li>Batterie trop chaude, trop froide ou basse tension.</li> <li>Chargeur trop chaud.</li> </ul>	<p>AVERTISSEMENT :</p> <p>HOT BATTERY WAITING TO CHARGE OU COLD BATTERY WAITING TO CHARGE OU VERY LOW BATTERY WAITING TO CHARGE OU HOT CHARGER WAITING TO CHARGE</p>	<p>Orange clignotant</p> 

## Menu Charger Setup



Videz tous les compartiments du chargeur avant d'accéder au menu de configuration du chargeur.

Le clavier du chargeur est situé sous l'écran du compartiment 1.

Pour accéder au menu Charger Setup, appuyez simultanément sur les boutons Flèche gauche et Flèche droite pendant une durée supérieure à la valeur Entry Time sélectionnée (3 secondes par défaut).

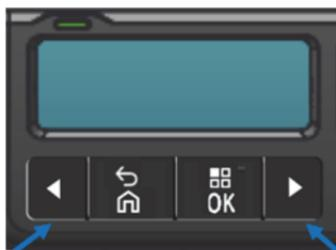

Flèche gauche

Flèche droite

**Figure 4** : Boutons de l'écran pour accéder au mode Setup

### Menu principal

À l'ouverture du menu Charger Setup, le message suivant s'affiche :

```
Press OK to entr  
SETUP MENU
```

Appuyez sur OK pour afficher le menu Charger Setup.

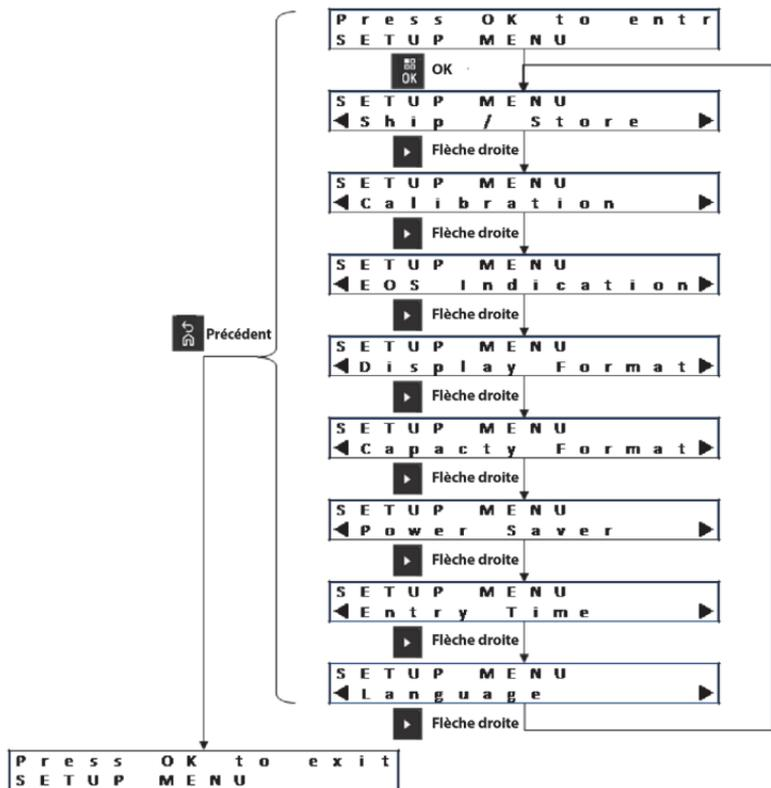

Figure 5 : Menu Charger Setup

## Sélection du menu Charger Setup

Dans chaque sélection du menu Setup :

- Pour naviguer dans les sélections de menus, appuyez sur la flèche droite.
- Pour naviguer dans les sélections de menus dans le sens inverse, appuyez sur la flèche gauche.
- Pour accéder au menu sélectionné ou sélectionner l'option souhaitée, appuyez sur OK.

**Remarque :** la coche indique l'option actuellement sélectionnée.

Introduit dans la version 1.11.01. Appuyez sur OK pour afficher le compartiment suivant sur l'écran du compartiment 1.

- Pour quitter le menu sélectionné, appuyez sur Back, puis appuyez sur OK pour confirmer.

Si vous n'appuyez sur aucun bouton du clavier pendant 10 minutes, le chargeur quitte le menu Charger Setup et revient à l'affichage normal des messages.

Les sélections de Charger Setup sont stockées dans la mémoire non volatile. Elles ne sont pas affectées par un cycle d'alimentation du chargeur.

## Menu Ship ou Storage

Il existe quatre options d'expédition/stockage :

- Disabled
- Ship Lithium-ion
- Long-Term Storage
- Long-Term Storage at 75% of Rated Capacity

Les sélections d'expédition de batteries au lithium-ion, de stockage à long terme et de stockage à long terme à 75 % prévalent sur les paramètres de calibration.

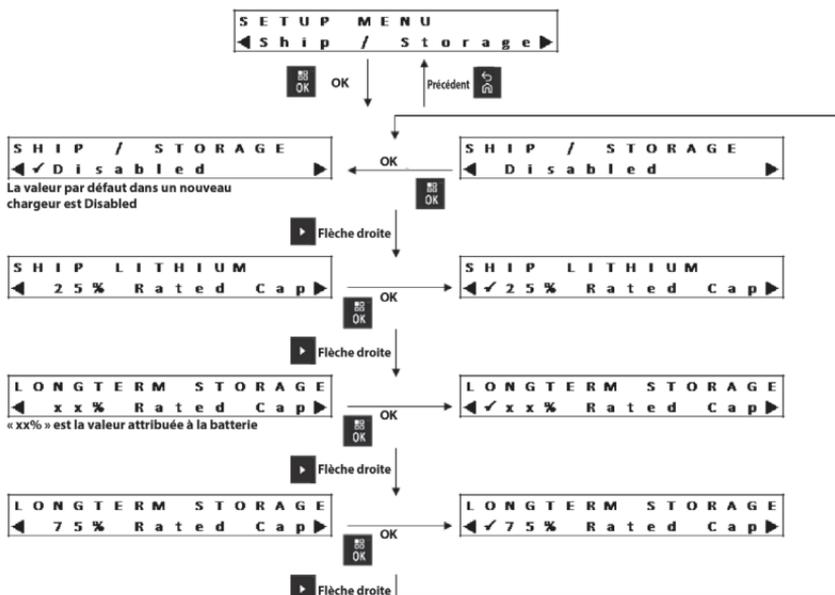

Figure 6 : Menu Ship/Storage

## Ship Lithium

L'option Ship Lithium définit l'état de charge d'une batterie au lithium-ion Motorola Solutions à une faible valeur autorisée pour le transport en vrac, soit environ 25 % de la capacité nominale.

Certaines batteries Motorola Solutions peuvent être entièrement déchargées avant de se charger jusqu'à la limite définie pour l'option Ship Lithium. Ceci est vrai notamment pour les batteries IMPRES 2 ou IMPRES n'ayant encore jamais été calibrées ou nécessitant un nouveau calibrage, ainsi que d'autres batteries Motorola Solutions authentiques non-IMPRES 2 ou IMPRES.

L'option Ship Lithium s'applique uniquement aux batteries au lithium-ion Motorola Solutions authentiques (IMPRES 2, IMPRES ou autres batteries Motorola Solutions au lithium-ion). Les autres batteries (telles que les batteries inconnues, batteries Motorola Solutions au nickel ou batteries Clamshell) engendrent une erreur.

## Long-Term Storage

L'option Long-Term Storage (stockage à long terme) place les batteries IMPRES 2 ou IMPRES dans un état de charge adapté au stockage de longue durée. En règle générale, l'état de charge de stockage préféré est nettement inférieur à la charge complète. La sélection `xx%` est une valeur programmée dans la batterie IMPRES 2 ou IMPRES ou, par défaut, 50 % de la capacité nominale. L'option de stockage à long terme à 75 % de la capacité nominale des batteries est disponible pour les scénarios où l'état de charge doit être supérieur, par exemple pour réduire la durée de charge complète si la batterie doit être rapidement réutilisable ou pour permettre le stockage pendant une durée plus longue.

Certaines batteries IMPRES 2 ou IMPRES peuvent être entièrement déchargées avant le chargement au niveau sélectionné pour le stockage à long terme. Ceci s'applique notamment aux batteries IMPRES 2 ou IMPRES qui n'ont encore jamais été calibrées ou qui nécessitent un nouveau calibrage.

Le stockage à long terme est possible uniquement pour les batteries IMPRES 2 ou IMPRES. Les autres batteries (telles que les batteries inconnues, batteries Motorola Solutions non-IMPRES ou batteries Clamshell) engendrent une erreur.

## Batteries IMPRES 2 avec mode Sleep

Certaines batteries IMPRES 2 sont dotées d'un mode Sleep (Veille). Le mode Sleep permet de prolonger le délai jusqu'à la prochaine charge de la batterie. À l'issue de la charge des options Ship Lithium ou Long-Term Storage, le chargeur met ces batteries en mode veille.

Lorsque vous placez une batterie IMPRES 2 en veille dans un chargeur, celle-ci quitte l'état de veille. Si la batterie a été préparée pour l'expédition de batteries au lithium, elle se remet en veille lorsque vous la placez dans un chargeur réglé sur Ship Lithium. Si la batterie a été préparée pour le stockage à long terme, elle se remet en veille lorsque vous la placez dans un chargeur réglé sur Long-Term Storage.

## Menu Calibration

Les options du menu Calibration permettent d'activer ou de désactiver la phase de décharge du calibrage/reconditionnement. La phase de décharge précède la phase de charge complète requise lors du calibrage/reconditionnement. Cette fonctionnalité s'avère utile si le chargeur est placé dans un lieu où les batteries doivent pouvoir être réutilisées aussi rapidement que possible en cas de besoin. Dans ces situations, attendre que la batterie se décharge peut poser problème.

Si une batterie IMPRES 2 ou IMPRES doit être calibrée et est déjà déchargée lorsque vous l'insérez dans le chargeur, le chargeur effectue le calibrage de la batterie en même temps que la charge.

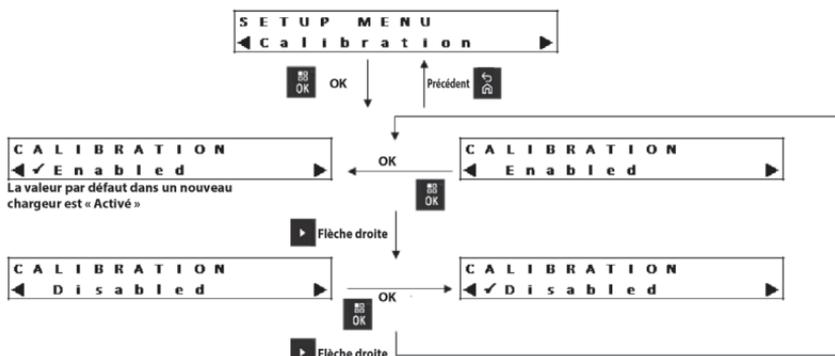

Figure 7 : Menu Calibration









**Tableau 20** : Options d'affichage de la capacité des batteries

Représentation	Description
xxx0mAh	Charge actuelle (état de charge) en milliampères par heure (mAh).
yyy%	Charge actuelle par rapport à la capacité potentielle ou à la capacité nominale en pourcentage. Lorsque la référence est la capacité potentielle, la valeur maximale est de 100 %. Lorsque la référence est la capacité nominale, la valeur maximale peut être supérieure à 100 %, en particulier pour une nouvelle batterie.
%BAR	L'équivalent de yyy% représenté par une barre à huit segments.

## Menu Power Saver

Pour être conforme aux basses limites d'alimentation en mode veille de certaines normes gouvernementales, le mode Power Saver permet au chargeur de désactiver tous les compartiments, sauf le compartiment 1, lorsqu'aucune activité n'y est détectée pendant un certain temps. Voici quelques exemples d'activité pouvant être détectées :

- Charge d'une batterie ou d'une radio.
- Calibrage/reconditionnement d'une batterie.
- Préparation d'autres batteries Motorola Solutions au lithium-ion authentiques pour l'expédition.
- Préparation de batteries IMPRES 2 ou IMPRES pour le stockage à long terme.
- Mode Charger Setup ou mode Analysis.
- Reprogrammation du chargeur.
- Communication avec le système Battery Fleet Management IMPRES.
- Toute indication par LED clignotante.

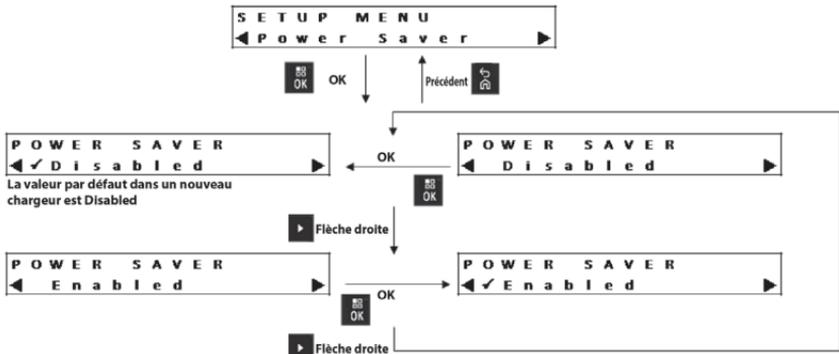

**Figure 11 : Menu Power Saver**

Le compartiment 1 reste activé, mais peut être mis en veille. Pour activer les autres compartiments, appuyez sur n'importe quel bouton du clavier. Tant que les autres compartiments ne sont pas activés, ils ne détectent pas l'insertion ou le retrait d'une radio ou d'une batterie.

## Menu Entry Time

La valeur Entry Time indique le temps pendant lequel vous devez maintenir le bouton enfoncé pour accéder au mode Charger Setup ou Charger Analyzer.

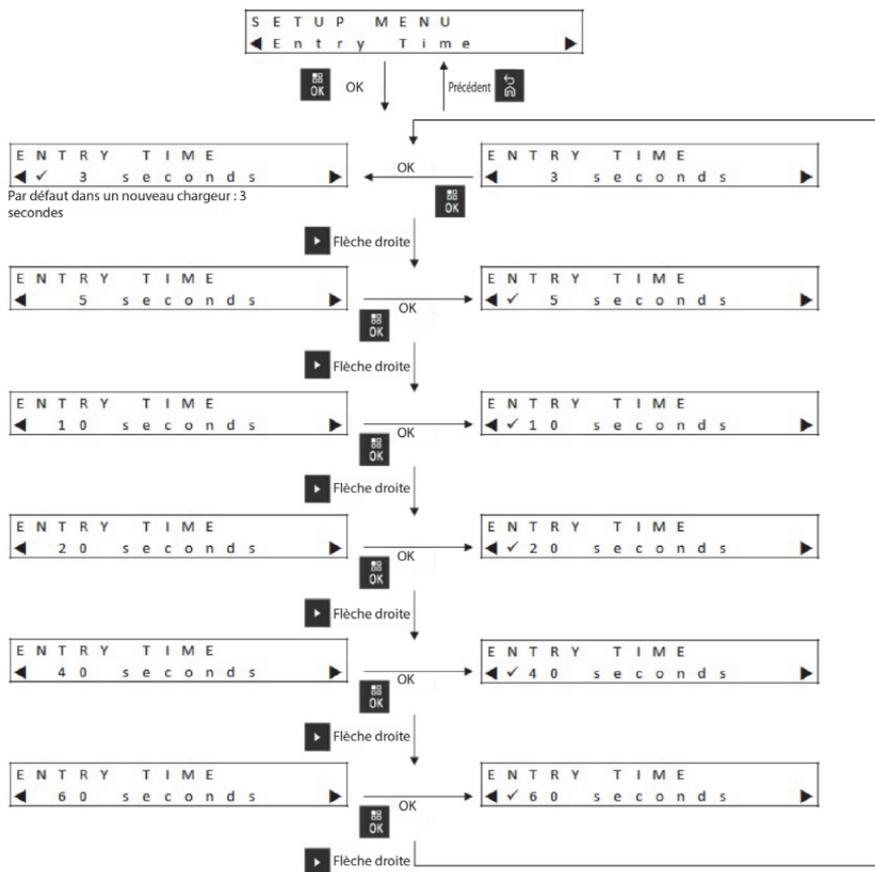

Figure 12 : Menu Entry Time

## Menu Language

La seule langue actuellement prise en charge sur l'affichage du chargeur est l'anglais (nord-américain).

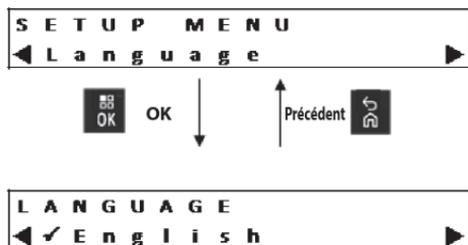

Figure 13 : Menu Language

## Mode Analyzer

Le clavier du chargeur est situé sous l'écran du compartiment 1.

Pour activer le mode Analyzer, appuyez sur le bouton OK pendant une durée supérieure à la valeur Entry Time sélectionnée (3 secondes par défaut).



Figure 14 : Bouton de l'écran pour accéder au mode Analyzer

À l'ouverture du menu Analyzer, le message suivant s'affiche :

Press OK to entr  
ANALYZER MODE

Appuyez sur OK pour afficher les informations disponibles sur la batterie.

## Mode Analyser de la version 1.0

Dans la version 1.0 du logiciel, le mode Analyser est limité au compartiment 1. Les informations du mode Analyser relatives au compartiment 1 et à son contenu s'affichent sur l'écran du compartiment 1. Si vous n'appuyez sur aucun bouton du clavier pendant 10 minutes, le chargeur quitte le mode Analyser et revient à l'affichage normal des messages.

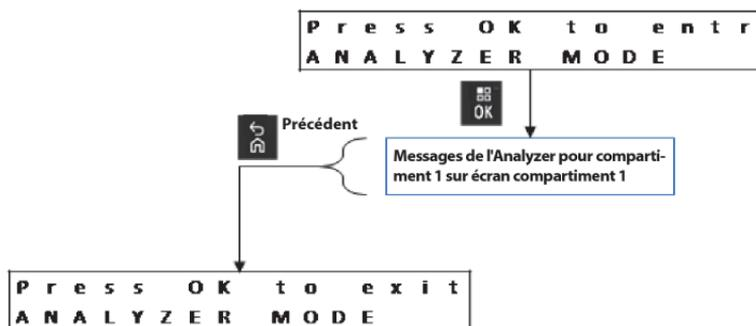

Figure 15 : Menu du mode Analyser de la version 1.0

## Mode Analyser de la version 1.05

Le mode Analyser a été amélioré avec la publication de la version logicielle 1.05. Pour les chargeurs dont chaque compartiment possède un écran, les informations de l'analyseur sont affichées sur l'écran adjacent au compartiment. Lorsque vous parcourez les informations de l'analyseur sur le compartiment 1, les autres écrans affichent les informations de l'analyseur disponibles pour le compartiment adjacent.

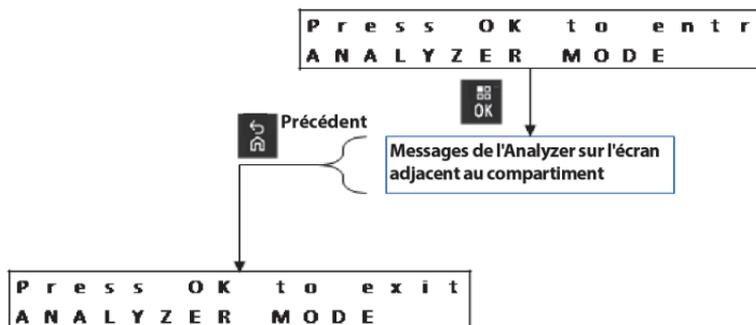

Figure 16 : Menu du mode Analyser de la version 1.05

## Mode Analyzer de la version 1.11.01

Le mode Analyzer a encore été amélioré avec la version logicielle 1.11.01. Pour les chargeurs dont seul le compartiment 1 possède un écran, celui-ci permet d'afficher les informations pour tout autre compartiment du chargeur. Les améliorations de la version 1.05 sont toujours présentes.

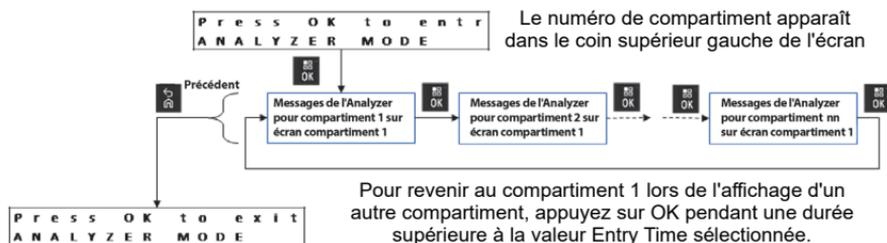

Figure 17 : Menu du mode Analyzer de la version 1.11.01

## Changement de batterie dans un compartiment

Si vous retirez une batterie, puis insérez cette batterie ou une autre dans le même compartiment, le paramètre qui s'affiche pour la deuxième batterie est le même que celui affiché pour la première batterie.

Par exemple, le paramètre *Battery IMPRES Cycles* est affiché pour une batterie IMPRES 2 ou IMPRES. Vous retirez cette batterie du compartiment. Vous insérez une autre batterie IMPRES 2 ou IMPRES dans le même compartiment. Le premier paramètre qui s'affiche pour la deuxième batterie est *Battery IMPRES Cycles*.

Cependant, la seconde batterie peut ne pas avoir le paramètre affiché pour la première batterie. Dans ce cas, le message d'identification s'affiche pour la deuxième batterie.

# Batterie IMPRES 2

## Écran adjacent au compartiment

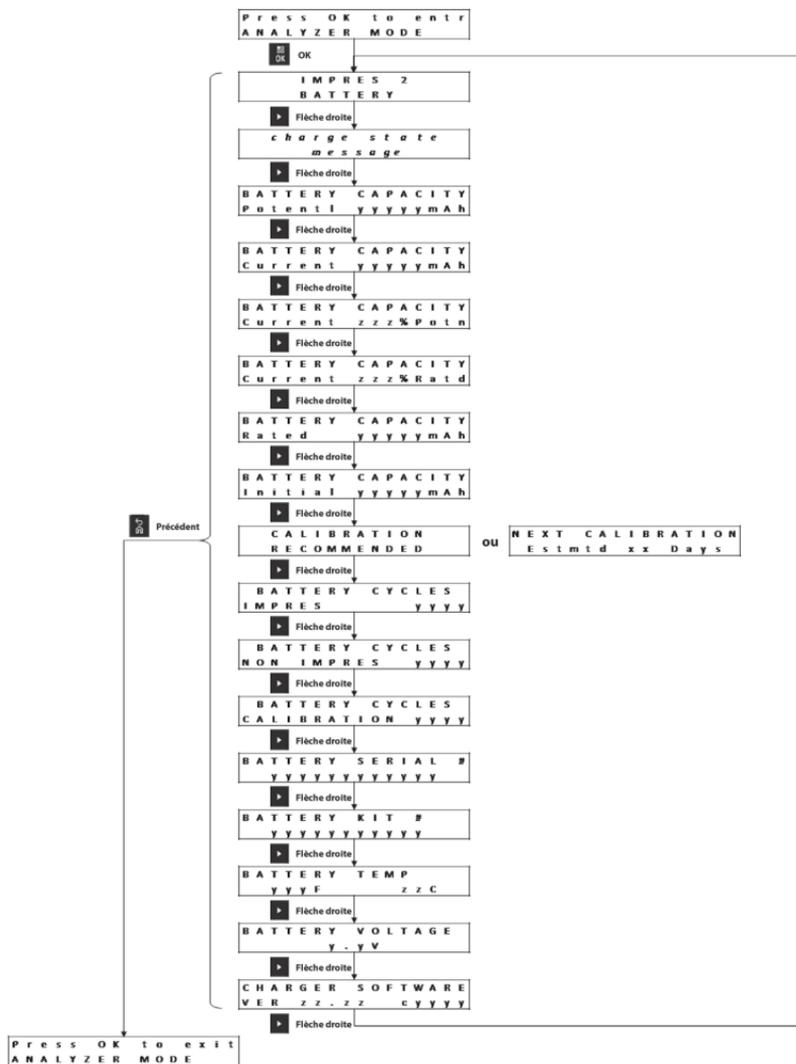

Figure 18 : Menu du mode Analyzer de batterie IMPRES 2 pour un écran adjacent au compartiment



# Affichage d'un autre compartiment sur l'écran 1

Le numéro de compartiment apparaît dans le coin supérieur gauche de l'écran

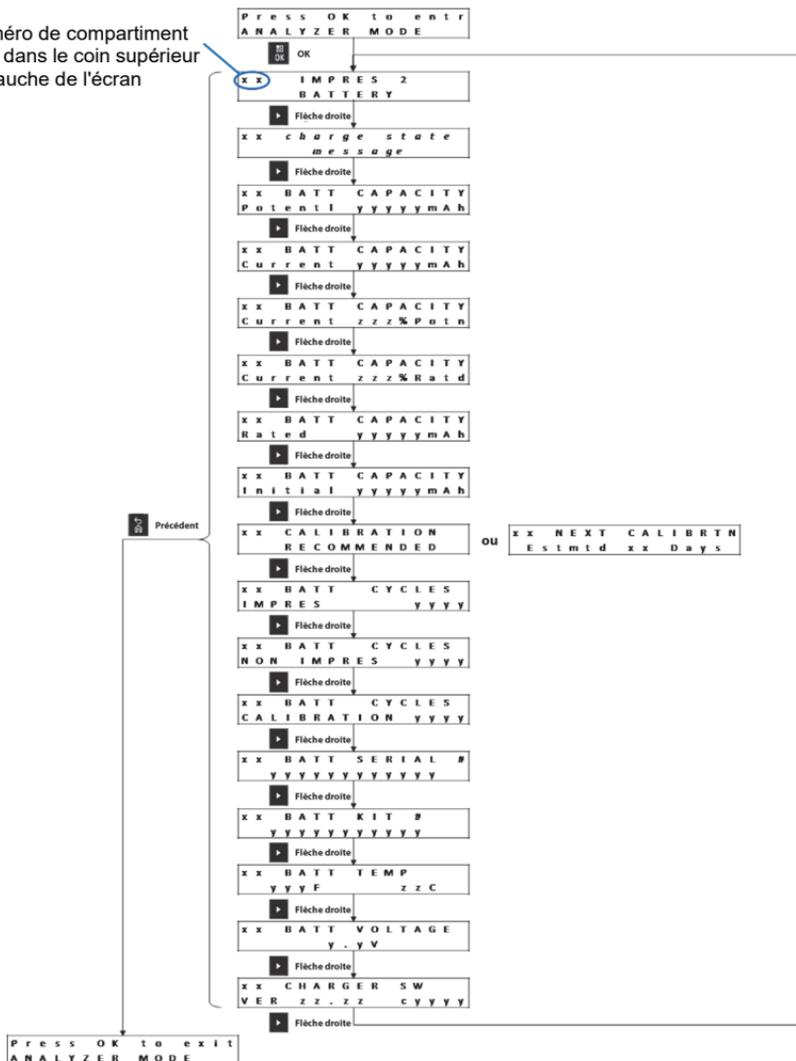

Figure 19 : Menu du mode Analyzer de batterie IMPRES 2 pour un autre compartiment que le compartiment 1

# Batterie IMPRES

## Écran adjacent au compartiment

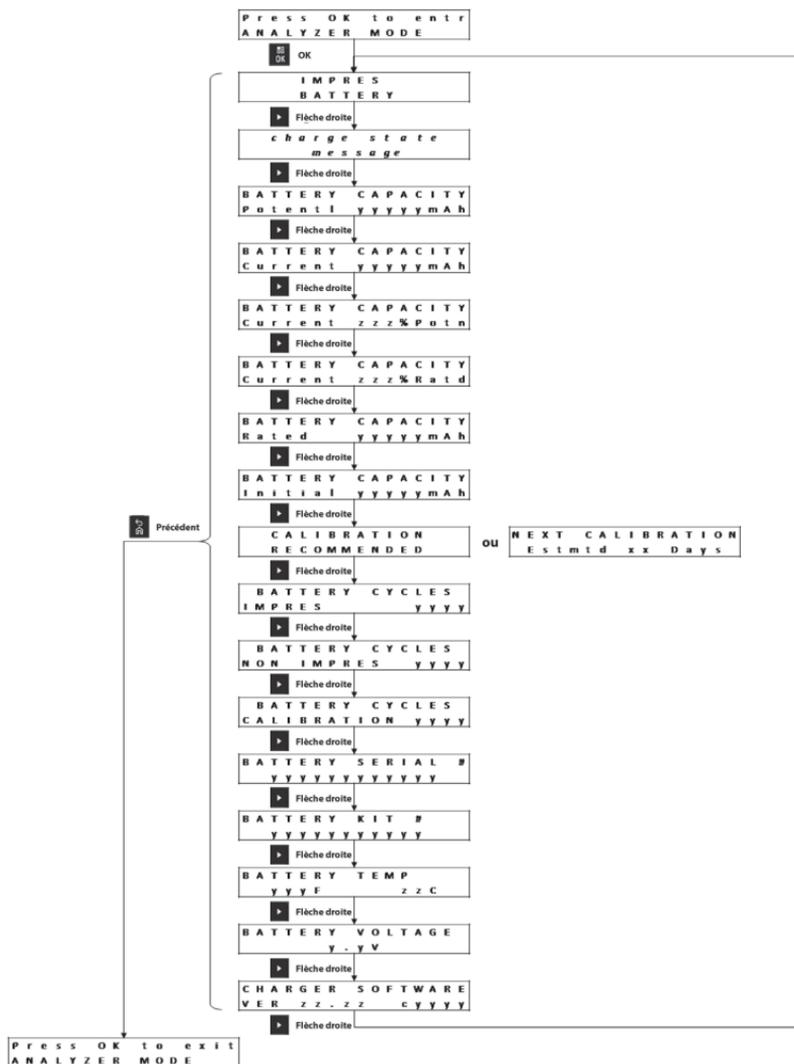

Figure 20 : Menu du mode Analyzer de batterie IMPRES pour un écran adjacent au compartiment

# Affichage d'un autre compartiment sur l'écran 1

Le numéro de compartiment apparaît dans le coin supérieur gauche de l'écran

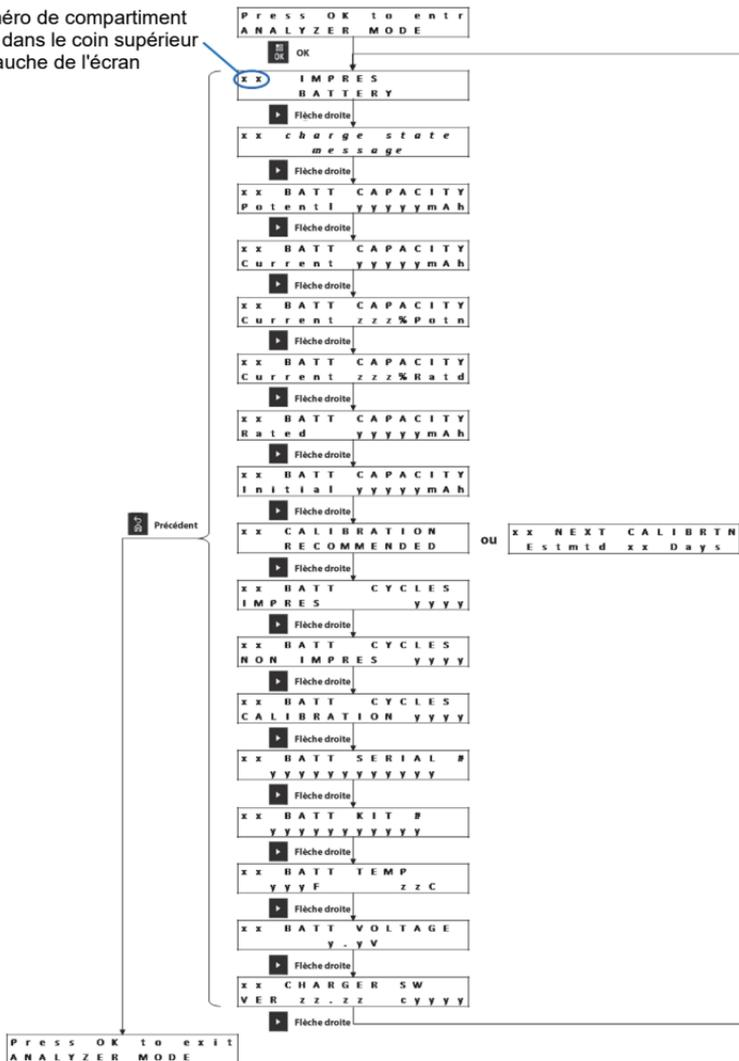
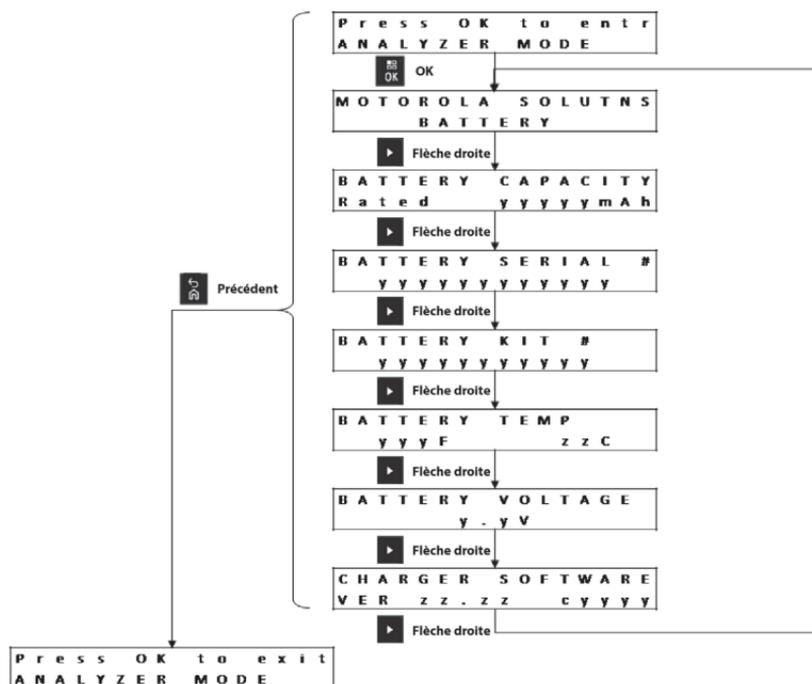

Figure 21 : Menu du mode Analyzer de batterie IMPRES pour un autre compartiment que le compartiment 1

## Autres batteries Motorola Solutions

### Écran adjacent au compartiment



**Figure 22 :** Menu du mode Analyzer des autres batteries Motorola Solutions pour un écran adjacent au compartiment

## Affichage d'un autre compartiment sur l'écran 1

Le numéro de compartiment apparaît dans le coin supérieur gauche de l'écran

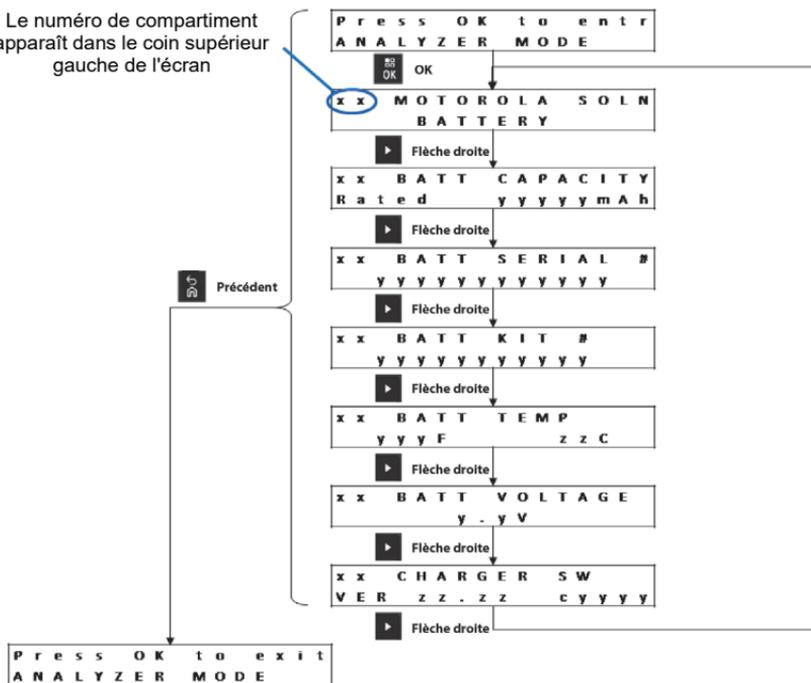

**Figure 23 :** Menu du mode Analyzer des autres batteries Motorola Solutions pour un autre compartiment que le compartiment 1

## Batterie inconnue

### Écran adjacent au compartiment

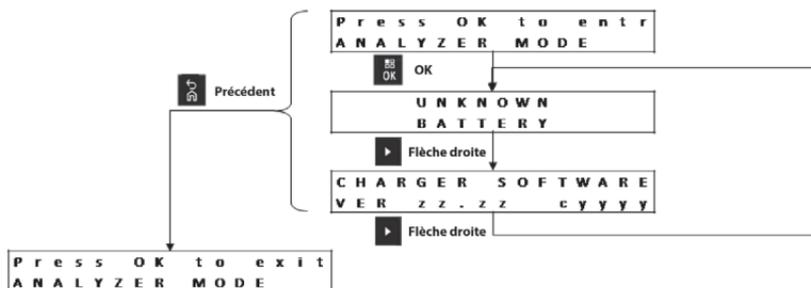

Figure 24 : Menu du mode Analyzer des batteries inconnues pour un écran adjacent au compartiment

### Affichage d'un autre compartiment sur l'écran 1

Le numéro de compartiment apparaît dans le coin supérieur gauche de l'écran

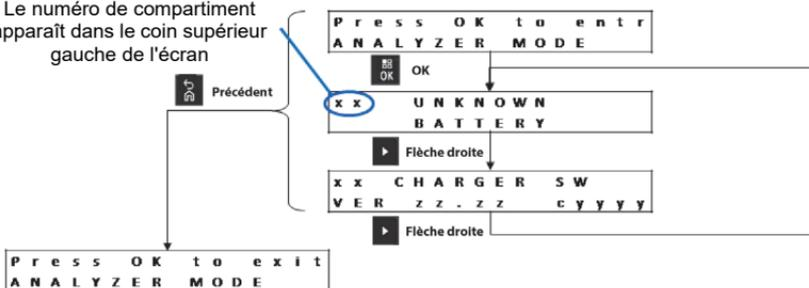
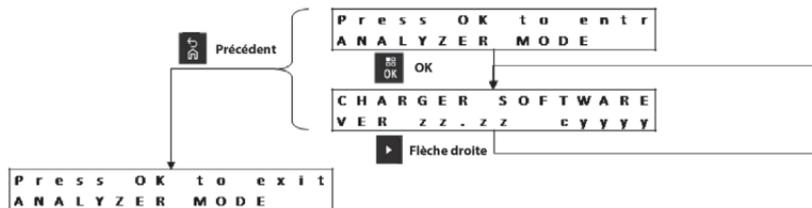

Figure 25 : Menu du mode Analyzer des batteries inconnues pour un autre compartiment que le compartiment 1

## Compartiment vide

### Écran adjacent au compartiment



**Figure 26 :** Menu du mode Analyzer pour un compartiment vide adjacent à l'écran

### Affichage d'un autre compartiment sur l'écran 1

Le numéro de compartiment apparaît dans le coin supérieur gauche de l'écran

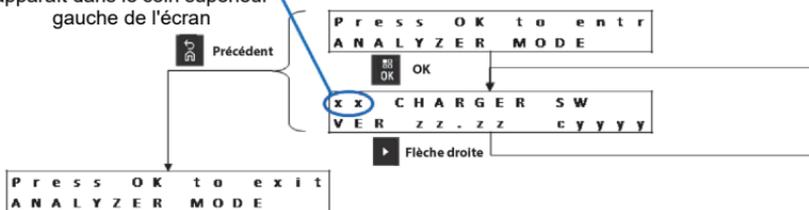

**Figure 27 :** Menu du mode Analyzer pour un compartiment vide autre que le compartiment 1

### Message d'état du chargeur

Certaines batteries IMPRES 2 sont dotées d'un mode Sleep. À l'issue des processus Ship Lithium, xx% Long-Term Storage ou 75% Long-Term Storage, une batterie dotée du mode veille est mise en veille. Le message d'état de charge en mode Analyzer vous permet de vérifier l'état de charge des batteries de veille.

**Tableau 21** : Ship Lithium activé et charge Ship Lithium terminée pour la batterie

Écran adjacent au compartiment	Affichage d'un autre compartiment sur l'écran 1
SHIP LI SLEEP xxx% Rated Cap	xx SHIP LI SLEEP xxx% Rated Cap

**Tableau 22** : xx% Long-Term Storage activé et charge xx% Long-Term Storage terminée pour la batterie

Écran adjacent au compartiment	Affichage d'un autre compartiment sur l'écran 1
STORAGE SLEEP xxx% Rated Cap	xx STORAGE SLEEP xxx% Rated Cap

Par exemple, le message d'état du chargeur n'est pas affiché si xx% Long-Term Storage est activé et que la charge 75% Long-Term Storage a été effectuée sur un autre chargeur.

## Reprogrammation du chargeur

Pour permettre la reprogrammation du chargeur, le module de communication doit être connecté à un ordinateur via un câble USB standard. Si vous utilisez le système Battery Fleet Management IMPRES pour lancer la reprogrammation du chargeur, le chargeur affiche les messages suivants.

Retrait des batteries des compartiments du chargeur avant la reprogrammation :

```
REPROGRAMMING  
REMOVE BATTERIES
```

Tous les compartiments du chargeur sont vides :

```
REPROGRAMMING  
WAITING FOR DATA
```

Données de reprogrammation en cours de téléchargement :

```
REPROGRAMMING  
Progress yyy%
```



Sur les chargeurs dont chaque compartiment dispose d'un écran, la valeur en pourcentage représente le pourcentage des données téléchargées avec succès dans le compartiment associé à l'écran. Sur les chargeurs disposant d'un seul écran (compartiment 1), la valeur en pourcentage représente le pourcentage des données téléchargées avec succès dans tous les compartiments.

Échec de la reprogrammation dans le compartiment identifié :

```
REPROGRAMMING  
POCKET#xx FAILED
```

Le compartiment de chargeur identifié démarre normalement en utilisant le logiciel précédent.

Téléchargement des données de reprogrammation terminé. La charge termine le processus de reprogrammation.

```
IMPRES 2  
CHARGER
```

Le processus de reprogrammation s'est terminé avec succès.

```
REPROGRAMMING  
COMPLETE
```

Le chargeur démarre normalement en utilisant le logiciel nouvellement téléchargé. Les paramètres définis par l'utilisateur sont conservés une fois la reprogrammation du chargeur terminée.

# Dépannage du chargeur

**Tableau 23 : Dépannage : Charge normale**

Problème	Procédure à suivre...
<p>La LED du compartiment ne clignote pas en vert pendant environ 1 seconde pour la mise sous tension du chargeur.</p>	<p>Vérifiez que le cordon d'alimentation est correctement branché dans le chargeur et dans la prise secteur. Assurez-vous que la prise est alimentée. Examinez les fusibles et remplacez-les si nécessaire.</p>
<p>La batterie ou la radio est insérée dans le compartiment, mais la LED correspondante reste ÉTEINTE et la batterie n'est pas identifiée sur l'écran adjacent.</p>	<p>Pour un compartiment autre que le 1, et si l'option Power Saver est activée, appuyez sur un bouton de menu. Voir ci-dessous.</p>
<p>LED rouge clignotante et message suivant à l'écran (si disponible) :</p> <p>NOT CHARGEABLE REMOVE &amp; REINSERT</p> <p>ou une batterie Motorola Solutions est dans le compartiment, mais le message à l'écran suivant s'affiche (si disponible) :</p> <p>UNKNOWN BATTERY</p>	<p> Retirez la batterie ou la radio du compartiment. Vérifiez que les contacts électriques sur la batterie et dans le compartiment du chargeur ne présentent aucune trace de contamination, de corrosion ou de dommages physiques. Vérifiez que la batterie est une batterie agréée par Motorola Solutions. D'autres batteries peuvent ne pas se charger. Nettoyez les contacts électriques de la batterie avec un chiffon sec. Coupez l'alimentation du chargeur, puis nettoyez les contacts électriques du compartiment avec un chiffon sec. Essayez avec une autre batterie. Si la panne disparaît, la batterie défectueuse doit être mise hors service. Si la panne persiste avec la batterie de remplacement, le chargeur est alors hors service.</p>
<p>Clignote-ment rouge/vert de la LED à la fin du calibrage.</p>	<p> La batterie IMPRES 2 ou IMPRES peut être proche de sa fin de vie (End of Service). La batterie est utilisable, mais la capacité disponible peut ne pas être adaptée à une utilisation intensive pendant une longue période. Applicable uniquement à la batterie APX NEXT XN : la batterie a été exposée à une température élevée pendant plus de 10 minutes. Il est recommandé de mettre la batterie hors service.</p>

**Tableau 23 : Dépannage : Charge normale (Suite)**

Problème	Procédure à suivre...
<p>Clignote- ment  orange/vert de la LED pendant environ 4 secondes à l'insertion de la batterie dans le chargeur.</p>	<p>La batterie IMPRES 2 ou IMPRES nécessite un calibrage/ reconditionnement. Dès que possible, placez la batterie dans un chargeur IMPRES 2 sur lequel le calibrage est activé et laissez le chargeur effectuer un calibrage complet (voyant vert fixe).</p>
<p>En mode Analyser, le compartiment 1 peut afficher un autre compartiment.</p>	<p>Le chargeur ne parvient pas à détecter l'écran sur au moins l'un des autres compartiments.</p>

**Tableau 24 : Dépannage : Charge Long-Term Storage**

Problème	Procédure à suivre...
<p>LED rouge  clignotante et message suivant à l'écran (si disponible) : WRONG BATT TYPE CANNOT LT STORE ou CANNOT DISCHARGE CANNOT LT STORE</p>	<p>Retirez la batterie du compartiment. Vérifiez que la batterie n'est PAS installée sur une radio. Vérifiez que la batterie est une batterie IMPRES 2 ou IMPRES. Les autres batteries engendrent une erreur. Nettoyez les contacts électriques de la batterie IMPRES 2 ou IMPRES avec un chiffon sec. Coupez l'alimentation du chargeur, puis nettoyez les contacts électriques du compartiment avec un chiffon sec. Essayez de remplacer la batterie par une autre batterie IMPRES 2 ou IMPRES. Si l'erreur disparaît, la batterie IMPRES 2 ou IMPRES est défectueuse et doit être mise hors service. Si l'erreur persiste avec la batterie IMPRES 2 ou IMPRES de remplacement, le chargeur est hors service.</p>
<p>LED rouge  clignotante et message suivant à l'écran (si disponible) : STORE INCOMPLETE Low Capacity:yy%</p>	<p>La capacité potentielle de la batterie IMPRES 2 ou IMPRES peut être inférieure à la sélection pour le stockage à long terme. La batterie peut être proche de sa fin de vie (End of Life).</p>

**Tableau 24 : Dépannage : Charge Long-Term Storage (Suite)**

Problème	Procédure à suivre...
<p>LED rouge clignotante et message suivant à l'écran (si disponible) :</p> <p>RADIO POCKET CANNOT LT STORE</p> <p>ou</p> <p>CHARGING POCKET CANNOT LT STORE</p>	<p>Le compartiment du chargeur n'est pas le compartiment standard pour charger une batterie (en raison des contacts électriques entre le chargeur et la batterie).</p> <ul style="list-style-type: none"> <li>• Un compartiment radio est un compartiment spécial dans lequel la batterie est fixée à une radio. Il n'y a pas de contacts externes sur la batterie et la batterie est chargée par le biais de contacts électriques sur la radio.</li> <li>• Un compartiment de charge est un compartiment qui utilise l'énergie du chargeur pour un usage spécial, tels que les ports de charge USB.</li> </ul> <p>Déplacez la batterie dans un compartiment standard ou remplacez le compartiment radio ou le compartiment de charge par un compartiment standard.</p>

**Tableau 25 : Dépannage : Charge Ship Lithium**

Problème	Procédure à suivre...
<p>LED rouge clignotante et message suivant à l'écran (si disponible) :</p> <p>WRONG BATT TYPE CANNOT SHIP LI</p>	<p>Retirez la batterie du compartiment. Vérifiez que la batterie n'est PAS installée sur une radio.</p> <p>Vérifiez que la batterie est une batterie IMPRES 2, IMPRES ou autre batterie Motorola Solutions au lithium-ion agréée. Les autres batteries engendrent une erreur.</p> <p>Nettoyez les contacts électriques de la batterie IMPRES 2, IMPRES ou autre batterie Motorola Solutions au lithium-ion agréée avec un chiffon sec.</p> <p>Coupez l'alimentation du chargeur, puis nettoyez les contacts électriques du compartiment avec un chiffon sec.</p> <p>Essayez de remplacer la batterie par une autre batterie IMPRES 2, IMPRES ou autre batterie Motorola Solutions au lithium-ion agréée. Si l'erreur disparaît, la batterie IMPRES 2, IMPRES ou autre batterie Motorola Solutions au lithium-ion agréée est défectueuse et doit être mise hors service.</p> <p>Si l'erreur persiste après le remplacement de la batterie IMPRES 2, IMPRES ou autre batterie Motorola Solutions au lithium-ion agréée, mettez le chargeur hors service.</p>

**Tableau 25 : Dépannage : Charge Ship Lithium (Suite)**

Problème	Procédure à suivre...
<p>LED rouge clignotante et message suivant à l'écran (si disponible) :</p> <p>SHIP INCOMPLETE Low Capacity:yy%</p>	<p>La capacité potentielle de la batterie Motorola Solutions au lithium-ion authentique peut être inférieure à la limite définie pour l'option Ship Lithium. La batterie peut être proche de sa fin de vie (End of Life).</p>
<p>LED rouge clignotante et message suivant à l'écran (si disponible) :</p> <p>RADIO POCKET CANNOT LT STORE</p> <p>ou</p> <p>CHARGING POCKET CANNOT SHIP LI</p>	<p>Le compartiment du chargeur n'est pas le compartiment standard pour charger une batterie (en raison des contacts électriques entre le chargeur et la batterie).</p> <ul style="list-style-type: none"><li>• Un compartiment radio est un compartiment spécial dans lequel la batterie est fixée à une radio. Il n'y a pas de contacts externes sur la batterie et la batterie est chargée par le biais de contacts électriques sur la radio.</li><li>• Un compartiment de charge est un compartiment qui utilise l'énergie du chargeur pour un usage spécial, tels que les ports de charge USB.</li></ul> <p>Déplacez la batterie dans un compartiment standard ou remplacez le compartiment radio ou le compartiment de charge par un compartiment standard.</p>

## Système Battery Fleet Management IMPRES

Le logiciel Battery Fleet Management IMPRES collecte automatiquement les données critiques des batteries IMPRES ou IMPRES 2 insérées dans un chargeur IMPRES. Les données critiques sont notamment l'ancienneté de la batterie, sa capacité, son historique de charge et de calibrage/reconditionnement, sa date de fabrication et sa date de mise en service. Le logiciel Battery Fleet Management IMPRES analyse les données des batteries, indique l'état des batteries et recommande quand remplacer les batteries. Vous pouvez ainsi déterminer rapidement et efficacement si vous devez transférer la batterie à un utilisateur nécessitant moins de capacité, acheter une nouvelle batterie ou rechercher une batterie manquante.

Battery Fleet Management IMPRES fournit des informations essentielles sur les batteries :

- Indique quand la capacité des batteries atteint un niveau trop faible.
- Permet d'assurer une capacité suffisante pour les utilisateurs pendant leur période de travail.
- Identifie les batteries dont la capacité devient trop faible afin qu'elles puissent être mises hors service.
- Élimine les temps d'arrêt et interruptions de travail imprévus.
- Évite les frais encourus par la mise au rebut prématurée des batteries.
- Assure la distribution et l'utilisation optimales des chargeurs.

Le logiciel d'application Battery Fleet Management IMPRES est évolutif et peut prendre en charge les systèmes de réseau monosites et multisites, comme illustré à la Figure 28. Le système Battery Fleet Management IMPRES prend en charge :

- un serveur administrateur système
- 19 clients distants
- 25 chargeurs IMPRES ou lecteurs de batterie IMPRES par client
- 25 000 batteries IMPRES dans un même lieu ou dans des secteurs géographiquement dispersés (le nombre total de batteries pour l'ensemble du système ne doit pas dépasser 25 000)

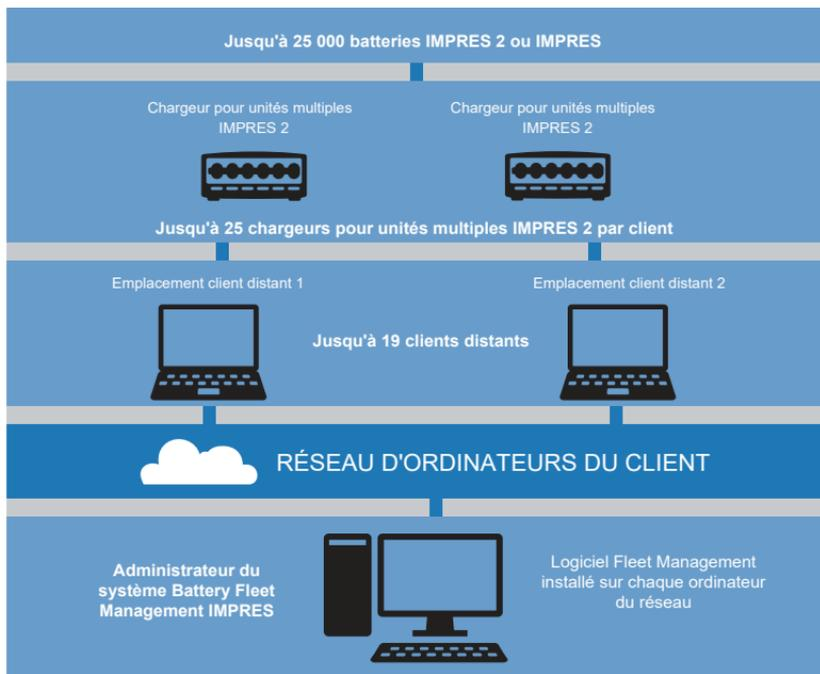

**Figure 28 :** Battery Fleet Management IMPRES par le biais de chargeurs en réseau

Battery Fleet Management IMPRES comprend trois composants principaux :

- Le logiciel d'application
- Une clé de licence logicielle
- Un câble USB pour connecter le chargeur IMPRES 2, le module de communication IMPRES 2, le IMPRES Charger Interface Unit (CIU) ou le lecteur des données de batterie IMPRES à un ordinateur qui héberge un client distant

Utilisez les rapports existants pour créer des rapports personnalisés afin d'afficher les informations les plus pertinentes pour votre entreprise. Les données sont stockées dans votre base de données et peuvent être exportées vers un fichier Excel™ ou imprimées. Le logiciel Battery Fleet Management IMPRES enregistre et organise diverses données pour vous permettre :

- d'afficher une vue instantanée de l'état de votre flotte de batteries ;
- d'évaluer si les batteries répondent à vos critères de performances ;
- de déterminer quand les batteries se rapprochent de la fin de leur cycle de vie ;
- de décider exactement à quel moment acheter de nouvelles batteries ;
- d'obtenir un rapport des batteries perdues ;
- d'optimiser votre utilisation du chargeur ;
- de surveiller tous les terminaux du système.

Serial Number	Alias	Group	Radio Family	Kit Number	Chemistry	FM	Rated Capacity	Potential Capacity	Date of First Use
1010000184479	Sam	Building 1	KT3 2000/2000/2000	HW901019	NiCd	No	1525	1391	8/1/2009
1010000184480	Yves	Security	APR	NW7N737A	NiMH	No	2100	1680	2/21/2008
1010000184484	Midval	Security	APR	NW7N736A	NiMH	Yes	2000	1600	8/19/2007
1010000185111	Phil	Administration	<FCG/PRO Series	HW901019	NiCd	No	1500	1240	9/4/2009
1010000185112	Paul	Building 1	KT3 2000/2000/2000	NW7N737A	NiMH	Yes	1700	1360	8/19/2008
1010000185335	Steve	Building 1	KT3 2000, X15M/PMR 1500	NW7N735A	Li-Ion	No	2000	1640	1/24/2008
1010000184961	Andrew	None	Other	HW901019	NiCd	No	2000	1600	8/6/2009
1010000184913	Jack	Building 2	KT3 2000, X15M/PMR 1500	NW7N735A	Li-Ion	No	2000	1640	8/11/2008
1010000180311	Gene	Building 2	KT3 2000, X15M/PMR 1500	NW7N735A	Li-Ion	No	2000	1640	8/21/2009
1010000184120	Neil	None	Other	HW901019	NiCd	Yes	2000	1600	8/22/2008
1010000180111	Carol	Administration	<FCG/PRO Series	HW901019	NiMH	Yes	1800	1350	11/11/2009
1010000411307	Pat	Building 1	KT3 2000/2000/2000	NW7N737A	NiMH	Yes	1700	1207	3/21/2006
1010000411306	Yves	Building 2	KT3 2000/2000/2000	HW901019	NiCd	No	1528	1368	8/2/2009
1010000389103	Bill	Security	APR	NW7N733A	Li-Ion	Yes	4100	2911	7/21/2006
101000039022	Frank	Security	APR	NW7N737A	NiMH	No	2100	1491	2/11/2009
1010000411317	Jack	Building 2	KT3 2000/2000/2000	NW7N737A	Li-Ion	Yes	1900	1264	1/13/2006
1010000421318	Eric	Administration	NCT07180	PRM9407A	Li-Ion	No	2150	1528	10/8/2008
1010000421319	Henry	Administration	<FCG/PRO Series	HW901019	NiCd	No	1500	1100	9/10/2009
1010000421321	Sam	Building 2	KT3 2000/2000/2000	NW7N737A	NiMH	No	2100	1491	2/22/2008
101000040942	Tam	Security	APR	NW7N733A	Li-Ion	Yes	4100	2911	1/19/2009
1010000421419	Paul	Administration	<FCG/PRO Series	HW901019	NiCd	No	1500	1100	8/6/2009
1010000192323	Sam	Building 1	APR	NW7N737A	NiMH	No	2000	1070	8/6/2007
1010000193812	Tim	Security	NCT07180	PRM9406A	Li-Ion	Yes	4000	2866	8/12/2007
1010000190513	Henry	Administration	APR	NW7N737A	NiMH	No	2100	1449	3/21/2008
1010000191416	Scott	Building 2	<FCG/PRO Series	HW901019	NiMH	No	1800	1242	10/11/2005
1010000191189	Steve	Security	KT3 2000/2000/2000	NW7N735A	Li-Ion	No	4100	2841	8/2/2008
1010000191223	Bill	Administration	APR	NW7N737A	NiMH	No	2100	1449	8/17/2008
1010000191763	Jack	Building 1	NCT07180	PRM9406A	Li-Ion	No	3300	2333	10/11/2007

Figure 29 : Rapport des batteries actives



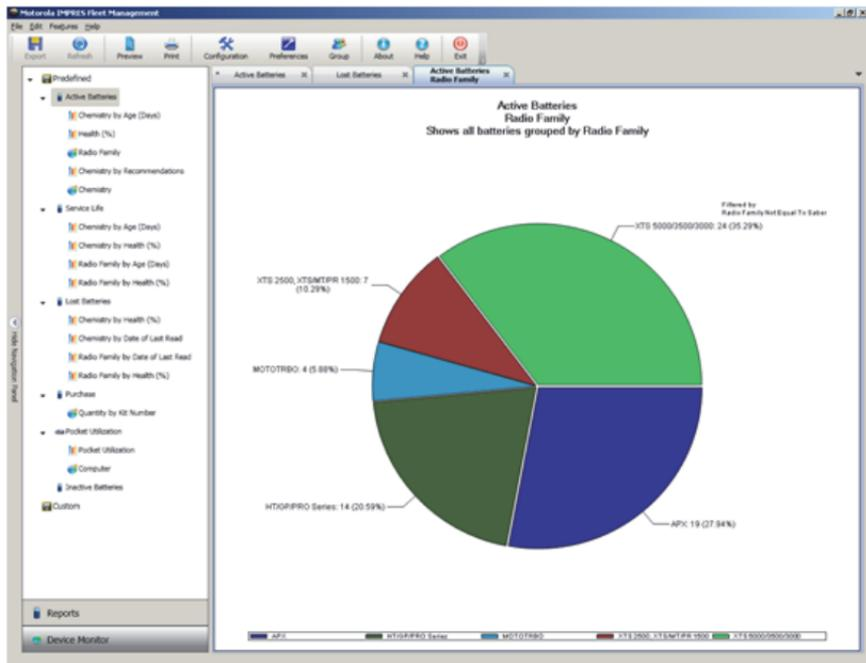

**Figure 30** : Batteries en cours d'utilisation par gamme de radios



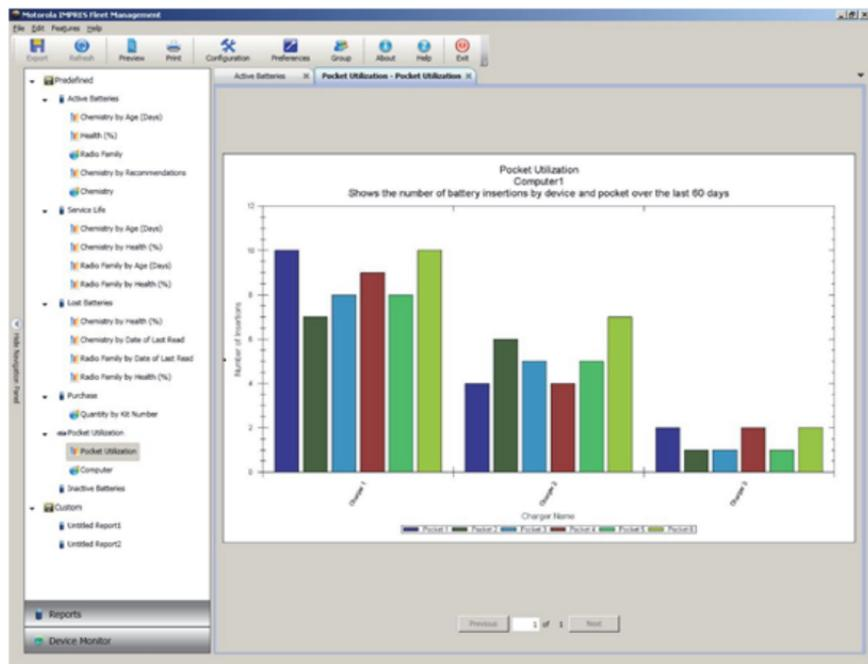

**Figure 32 : Utilisation des compartiments du chargeur**

## Fixation murale pour chargeur pour unités multiples

Un support de montage mural (réf. 0705559L01) est disponible pour le chargeur pour unités multiples. Contactez votre revendeur local pour commander cet article. L'installation est représentée ci-dessous.



AVERTISSEMENT

- Ce support de montage mural doit être installé par un technicien qualifié et expérimenté. L'installation du produit par un technicien non spécialisé est très dangereuse et peut entraîner un risque de dommage ou de blessure.
- N'installez pas le produit sur une surface qui ne peut pas supporter son poids. Si l'emplacement n'est pas assez solide, le support mural peut se détacher et entraîner un risque de blessure.
- Ne l'installez pas sur une structure sujette aux vibrations, mouvements ou risques de choc.

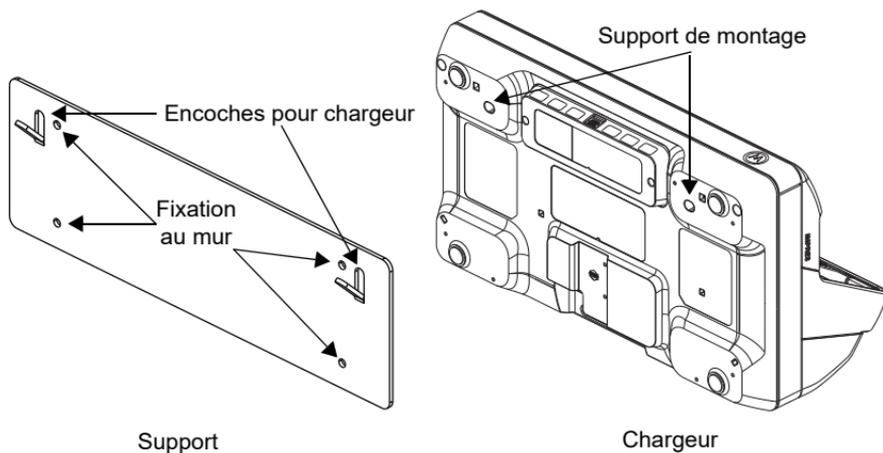

**Figure 33** : Trous de montage du support et position des encoches

## Fixation du chargeur pour unités multiples au support mural

1. Placez le support de montage mural à l'emplacement souhaité et marquez l'emplacement des trous de fixation sur le mur.



Attention

Assurez-vous que la zone à l'arrière de la surface de montage est libre de tous fils électriques, câbles ou tuyaux avant de découper, percer ou installer les vis de montage.

2. Fixez le support au mur à l'aide du matériel de montage adapté au type de matériau du mur où vous effectuez le montage. Percez en vous basant sur les trous de fixation marqués sur les surfaces murales.
3. Fixez correctement le support mural en installant le matériel de fixation sur les trous de fixation marqués sur le support mural.

**Remarque :** il est recommandé d'utiliser des vis autotaraudeuses 10-16 x 1,5" et des rondelles (non fournies) sur les montants en bois et les murs en béton/brique plats et solides.

4. Accrochez le chargeur pour unités multiples sur le support mural.

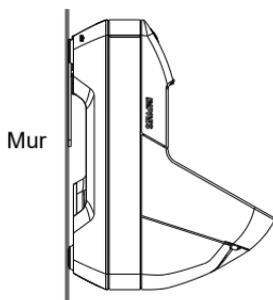

**Figure 34 :** Chargeur monté sur le support mural

# ISTRUZIONI IMPORTANTI SULLA SICUREZZA

## Conservare le presenti istruzioni

Questo documento contiene importanti istruzioni sulla sicurezza e sul funzionamento. Leggere attentamente queste istruzioni e conservarle come riferimento futuro.

Prima di utilizzare il caricabatteria, leggere tutte le istruzioni e gli avvisi riportati su (1) caricabatteria, (2) batteria e (3) radio che utilizza la batteria.



ATTENZIONE

1. Per ridurre il rischio di danni al cavo di alimentazione, tirare la spina e non il cavo quando si scollega l'alimentatore dalla presa di corrente CA o dal caricabatteria.
2. Non utilizzare prolunghe a meno che non sia strettamente necessario. L'utilizzo di una prolunga inadeguata può causare incendi e scosse elettriche. Se è necessario utilizzare una prolunga, assicurarsi che le dimensioni del cavo siano di 18 AWG per lunghezze fino a 2 m (6,5 piedi) e di 16 AWG per lunghezze fino a 3 m (9,8 piedi).
3. Per ridurre il rischio di incendi, scosse elettriche o lesioni personali, non utilizzare il caricabatteria se è rotto o danneggiato. Consegnarlo invece a un rappresentante dell'assistenza tecnica di Motorola Solutions.
4. Non disassemblare il caricabatteria. Il disassemblaggio del caricabatteria può causare scosse elettriche o incendi. Le uniche parti riparabili/di ricambio sono gli inserti dei vani NNTN9212 e NNTN9213. Seguire le istruzioni riportate nei kit di inserti MN005697A01 per vani di ricarica del caricabatteria multiunità IMPRES 2 serie APX.
5. Per ridurre il rischio di scosse elettriche, scollegare l'alimentatore del caricabatteria dalla presa di corrente CA prima di eseguire qualsiasi operazione di manutenzione o pulizia.
6. Per ridurre il rischio di lesioni personali, ricaricare unicamente batterie ricaricabili autorizzate Motorola Solutions, come riportato nella Tabella 2. Batterie di altro tipo potrebbero esplodere causando lesioni personali e danni.
7. L'utilizzo di accessori non consigliati da Motorola Solutions può causare incendi, scosse elettriche o lesioni personali.

## Linee guida per un utilizzo sicuro

- Questa apparecchiatura non è adatta per l'utilizzo in esterni. Utilizzare unicamente in luoghi asciutti.
- La temperatura ambiente massima intorno al caricabatteria non deve superare i 40 °C (104 °F).
- Mentre è inserita in un vano del caricabatteria, la radio può essere ACCESA solo se trasmette dati in modalità wireless, ad esempio tramite Wi-Fi. In caso contrario, è necessario SPEGNERE la radio.
- Collegare il caricabatteria solo a un alimentatore appropriato riportato nella Tabella 3.
- La presa CA alla quale viene collegato il cavo di alimentazione deve trovarsi nelle vicinanze ed essere facilmente accessibile.
- Verificare che il cavo di alimentazione del caricabatteria sia collegato in un posto in cui non corra il rischio di essere calpestato, danneggiato, esposto all'acqua o ad altre fonti di danno.
- Collegare il cavo di alimentazione solo a una presa di corrente CA dotata di fusibili e cavi del voltaggio corretto, come specificato nelle informazioni riportate nel prodotto.
- Scollegare l'apparecchio dalla rete elettrica rimuovendo il cavo di alimentazione dalla presa di corrente CA.
- Non collegare più caricabatteria del necessario a un circuito da 15 A o 20 A, seguendo le limitazioni indicate sulla ciabatta verticale certificata in uso. SI SCONSIGLIA l'uso di ciabatte verticali daisy-chain. Limitare il carico del circuito all'80% del valore nominale del circuito.
- Utilizzare esclusivamente vani autorizzati Motorola Solutions.

## Modelli supportati

**Tabella 1: Modelli supportati e descrizione**

Modello	Descrizione
PS000029A01 (UNIV) PS000029A04 (EU/UK) PS000029A06 (RK)	Caricabatteria multiunità IMPRES 2 APX per 1 display con riprogrammazione del caricabatteria e sistema di gestione del parco batterie
PS000029A02 (UNIV) PS000029A05 (EU/UK) PS000029A07 (RK)	Caricabatteria multiunità IMPRES 2 APX per 6 display con riprogrammazione del caricabatteria e sistema di gestione del parco batterie
PS000029A03 (EU/UK) PS000029A08 (RK)	Caricabatteria multiunità IMPRES 2 APX per 6 display con riprogrammazione del caricabatteria, sistema di gestione del parco batterie e ricarica di accessori USB
PS000337A01 (US/NA, AU/NZ)	Caricabatteria multiunità IMPRES 2 APX NEXT per 6 display con riprogrammazione del caricabatteria e sistema di gestione del parco batterie

## Batterie autorizzate Motorola Solutions

I caricabatteria IMPRES 2 serie APX caricheranno le batterie riportate nella Tabella 2. Le batterie possono essere collegate a una radio o utilizzate in modo autonomo.

**Tabella 2: Batterie autorizzate Motorola Solutions**

Kit (PN)	Descrizione
NNTN7033	IMPRES agli ioni di litio FM (HazLoc) IP67 da 4100 mAh
NNTN7034	IMPRES agli ioni di litio IP67 da 4200 mAh
NNTN7035	IMPRES NiMH FM (HazLoc) robusta da 2000 mAh
NNTN7036	IMPRES NiMH FM (HazLoc) IP67 da 2000 mAh
NNTN7037	IMPRES NiMH IP67 da 2100 mAh
NNTN7038	IMPRES agli ioni di litio IP67 da 2900 mAh
NNTN7573	IMPRES NiMH robusta da 2100 mAh
NNTN8092	IMPRES agli ioni di litio FM (HazLoc) robusta da 2300 mAh
NNTN8182	IMPRES agli ioni di litio robusta da 2900 mAh
NNTN8921	IMPRES 2 agli ioni di litio TIA4950 (HazLoc) IP67 robusta da 3700 mAh
NNTN8930	IMPRES 2 agli ioni di litio TIA4950 (HazLoc) IP67 robusta da 2700 mAh



**Tabella 2: Batterie autorizzate Motorola Solutions (continua)**

Kit (PN)	Descrizione
NNTN9087	IMPRES 2 agli ioni di litio IP68 da 3800 mAh
NNTN9088	IMPRES 2 agli ioni di litio DIVISION 2 (HazLoc) IP68 da 3800 mAh
NNTN9089	IMPRES 2 agli ioni di litio IP68 da 5650 mAh
NNTN9090	IMPRES 2 agli ioni di litio DIVISION 2 (HazLoc) IP68 da 5650 mAh
NNTN9126	IMPRES 2 agli ioni di litio IP68 da 4400 mAh
NNTN9127	IMPRES 2 agli ioni di litio DIVISION 2 (HazLoc) IP68 da 4400 mAh
PMNN4403	IMPRES agli ioni di litio IP67 da 2150 mAh
PMNN4485	IMPRES 2 agli ioni di litio IP67 robusta da 2500 mAh
PMNN4486	IMPRES 2 agli ioni di litio IP67 robusta da 3400 mAh
PMNN4487	IMPRES 2 agli ioni di litio IP67 robusta da 4400 mAh
PMNN4494	IMPRES 2 agli ioni di litio IP67 robusta da 5000 mAh
PMNN4504	IMPRES 2 agli ioni di litio DIVISION 2 (HazLoc) IP67 robusta da 3400 mAh
PMNN4505	IMPRES 2 agli ioni di litio DIVISION 2 (HazLoc) IP67 robusta da 4850 mAh
PMNN4547	IMPRES 2 agli ioni di litio TIA4950 (HazLoc) IP68 robusta da 3100 mAh
PMNN4573	IMPRES 2 agli ioni di litio TIA4950 (HazLoc) IP68 robusta da 4600 mAh
PMNN4812	IMPRES 2 APX NEXT XN agli ioni di litio DIV 2 (HAZLOC) IP68 da 3400 mAh

## Alimentatori autorizzati Motorola Solutions

**Tabella 3: Alimentatori autorizzati Motorola Solutions**

Kit (PN)	Descrizione
3087791G01	Cavo di alimentazione, US/NA
3087791G04	Cavo di alimentazione, EU
3087791G07	Cavo di alimentazione, UK/HK
3087791G10	Cavo di alimentazione, AU/NZ
3087791G13	Cavo di alimentazione, AR
3087791G16	Cavo di alimentazione, KR
3087791G20	Cavo di alimentazione, JP
3087791G22	Cavo di alimentazione, BR
CB000460A01	Cavo di alimentazione, CH

## Moduli di comunicazione autorizzati Motorola Solutions

**Tabella 4:** Moduli di comunicazione autorizzati Motorola Solutions

Kit (PN)	Descrizione
AS000013A01	Modulo per la gestione del parco batterie e per la riprogrammazione del caricabatteria IMPRES 2
AS000012A02	Modulo per la riprogrammazione del caricabatteria IMPRES 2/ gestione del parco batterie e per la ricarica degli accessori

### Caricabatteria, vano e modulo di comunicazione

Il caricabatteria adattivo IMPRES 2™ serie APX è un sistema per la manutenzione della batteria completamente automatico.

Il caricabatteria è dotato delle seguenti funzioni:

- Sistema di ricarica adattivo per un'ampia gamma di batterie, incluse le batterie IMPRES 2, IMPRES™ e altre batterie Motorola Solutions originali.
- Vano che può ospitare una batteria autonoma o una radio con batteria collegata.
- LED rosso/ambra/verde che indica lo stato del vano del caricabatteria.
- Modulo di comunicazione
  - Riprogrammazione del caricabatteria
  - Caricamento dati della batteria IMPRES 2 o IMPRES in un sistema IMPRES Battery Fleet Management
  - (Opzionale) Sei porte di ricarica USB tipo A, ciascuna con 0,5 A per la ricarica di un accessorio USB
- Menu della tastiera
  - Charger Setup
  - Battery Analysis
- Visualizzazione delle informazioni sul vano 1.
  - Display opzionali su altri vani
- Preparazione di una batteria IMPRES 2 o IMPRES autonoma per la conservazione a lungo termine oppure preparazione di una batteria agli ioni di litio Motorola Solutions autonoma per la spedizione. **NON** lasciare le batterie nel caricabatteria una volta completata la preparazione per la conservazione a lungo termine o dopo la spedizione della batteria agli ioni di litio.

- Funzioni di efficienza energetica
  - Conforme agli standard per apparecchiature della California Energy Commission per piccoli sistemi di ricarica delle batterie: i vani del caricabatteria entreranno automaticamente in modalità di sospensione per riattivarsi al fine di rispondere all'azione dell'utente o quando una batteria viene inserita nel vano.
  - Conforme con i limiti di corrente in Europa per lo stato in standby (kit caricabatteria europeo). Quando la modalità Power Saver è abilitata, tutti vani di ricarica, tranne il n. 1, si spengono automaticamente se non viene eseguita alcuna operazione per un periodo di tempo. Premendo un pulsante sulla tastiera, i vani si riattivano.
- La ricarica delle batterie agli ioni di litio IMPRES 2 è più veloce.
- La ricarica è più veloce.
- Il ciclo di vita della batteria è prolungato.

Si sconsiglia di utilizzare la radio mentre è nel caricabatteria.

L'utilizzo della radio durante il processo di ricarica comporta una riduzione delle prestazioni e l'aumento del tempo richiesto per la ricarica.

Durante la calibrazione o il ricondizionamento, la batteria viene scaricata del tutto prima di ricaricarla completamente. Di conseguenza, la radio potrebbe spegnersi quando la batteria viene scaricata. Si consiglia di calibrare la batteria senza radio collegata o con la radio collegata ma spenta.

## Batterie e caricabatteria IMPRES 2 e IMPRES

### Funzioni e vantaggi

La soluzione di alimentazione IMPRES 2 è un avanzato sistema di alimentazione costituito da tre elementi principali sviluppato da Motorola Solutions.

Il sistema comprende:

- Batterie IMPRES 2 e IMPRES
- Caricabatteria adattivo IMPRES 2
- Radio IMPRES

Ricaricare le batterie IMPRES 2 o IMPRES utilizzando un caricabatteria adattivo IMPRES 2, che calibra/ricondiziona periodicamente la batteria, offre i seguenti vantaggi:

- Prolunga la durata della batteria.
- Misura la capacità della batteria e ne determina l'attuale stato di carica, fornendo un'indicazione sul tempo di utilizzo effettivo.

- Monitora il modello di utilizzo della batteria IMPRES 2 o IMPRES.
- Aggiorna le informazioni del modello memorizzate nella batteria IMPRES 2 o IMPRES.
- Esegue automaticamente la calibrazione/il ricondizionamento solo quando necessario.
- Riduce al minimo il riscaldamento della batteria IMPRES 2 o IMPRES, indipendentemente da quanto tempo la batteria viene lasciata nel vano.
- Ricarica periodicamente e completamente una batteria lasciata nel vano di ricarica, garantendo all'utente che sia sempre pronta all'uso.
- Elimina l'effetto memoria della batteria al nichel, eliminando così la necessità di acquistare apparecchiature speciali o di rivolgersi a personale qualificato per mantenere la durata della batteria.

Utilizzando questo esclusivo sistema brevettato, non c'è bisogno di rilevare e registrare l'uso della batteria IMPRES 2 o IMPRES, eseguire manualmente la calibrazione o il ricondizionamento oppure rimuovere le batterie dai caricabatteria al termine della ricarica.

## Inizializzazione della batteria IMPRES 2 o IMPRES

Per la piena funzionalità della batteria IMPRES 2 o IMPRES, è necessario inizializzare una nuova batteria IMPRES o IMPRES 2 mediante il caricabatteria. Il caricabatteria rileva automaticamente la nuova batteria IMPRES 2 o IMPRES e avvia automaticamente l'inizializzazione.

L'inizializzazione è la prima operazione di calibrazione/ricondizionamento della batteria IMPRES 2 o IMPRES. La procedura viene completata in due fasi. La prima fase consiste nello scaricare la batteria, come indicato dal LED di stato **ambra fisso**. La seconda consiste nel caricarla completamente, come indicato dal LED **verde fisso**. Questo processo può richiedere fino a 12 ore o anche di più, a seconda dello stato di carica e della capacità della batteria. L'interruzione di queste fasi comporta un ritardo dell'inizializzazione fino alla successiva ricarica.

## IMPRES 2 o IMPRES da vano a vano

Quando si ricaricano batterie IMPRES 2 o IMPRES, il caricabatteria IMPRES 2 o IMPRES registra le informazioni di ricarica nella memoria della batteria. Se la batteria IMPRES 2 o IMPRES è stata rimossa dal vano di un caricabatteria IMPRES 2 o IMPRES e, nel giro di 30 minuti, inserita nello stesso vano o in un vano diverso del caricabatteria IMPRES 2 o IMPRES, la ricarica riprende dal punto in cui era stata interrotta. Questa funzione impedisce il sovraccarico della batteria e riduce al minimo la perdita del ciclo di vita. Ciò è particolarmente importante quando si effettua la ricarica di batterie al nichel.

## Processo di calibrazione/ricondizionamento automatico della batteria IMPRES 2 o IMPRES

Il caricabatteria IMPRES 2 valuta automaticamente le condizioni di una batteria IMPRES o IMPRES 2. In base a questa condizione, il caricabatteria esegue automaticamente la calibrazione/il ricondizionamento della batteria. L'interruzione di una fase di scaricamento o ricarica completa comporta ritardi nella calibrazione fino alla successiva ricarica.

Utilizzare la modalità Charger Setup per attivare o disattivare la calibrazione/il ricondizionamento. Se il processo è disattivato e la batteria IMPRES 2 o IMPRES richiede la calibrazione/il ricondizionamento, il LED si illumina **alternando i colori ambra e verde** quando la batteria viene inserita e dopo essere stata caricata.

**Nota:** la batteria IMPRES 2 o IMPRES deve trovarsi all'esterno del vano del caricabatteria per più di 30 minuti per avviare il processo di calibrazione/ricondizionamento automatico.

### Batteria IMPRES con calibrazione automatica e ricondizionamento



**ATTENZIONE:** le batterie IMPRES 2 che presentano questa icona sull'etichetta non richiedono calibrazione e ricondizionamento periodici quando vengono inserite nel caricabatteria IMPRES 2 (con versione software V2.05 o successive).

**Nota:** assicurarsi che il caricabatteria sia sempre aggiornato con il firmware più recente. Il pacchetto dell'applicazione MSI Charger Reprogrammer può essere scaricato dal sito Web Motorola Solutions o Motorola Online (MOL).

### Aggiornamento del firmware

**Nota:** si applica a tutti i dispositivi o caricabatteria IMPRES di 1a e 2a generazione, che includono unità di interfaccia per caricabatteria (CIU), lettore dati batteria (BDR), caricabatteria a singola unità (SUC), caricabatteria a doppia unità (DUC) e caricabatteria multiunità (MUC).

Rimuovere tutte le batterie inserite dal caricabatteria o dal dispositivo interessato prima di aggiornare un caricabatteria o un dispositivo IMPRES a una versione più recente.

1. Collegare il dispositivo o il caricabatteria a un computer tramite USB. Il dispositivo o il caricabatteria collegato viene visualizzato nella finestra principale dello strumento per la riprogrammazione del caricabatteria MSI.

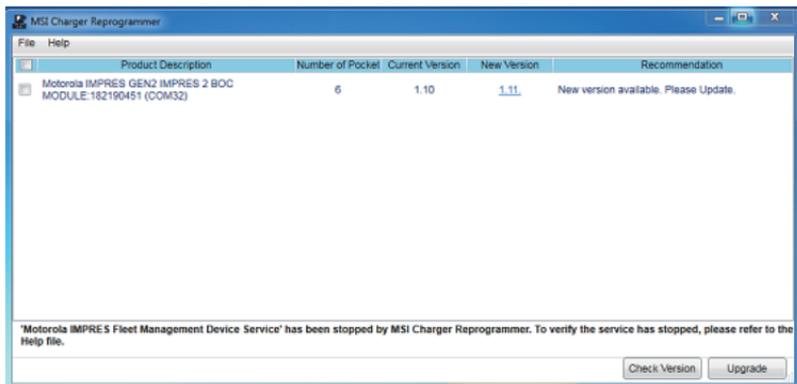

2. Fare clic su Verifica versione per trovare la versione più recente disponibile sul server MSI.

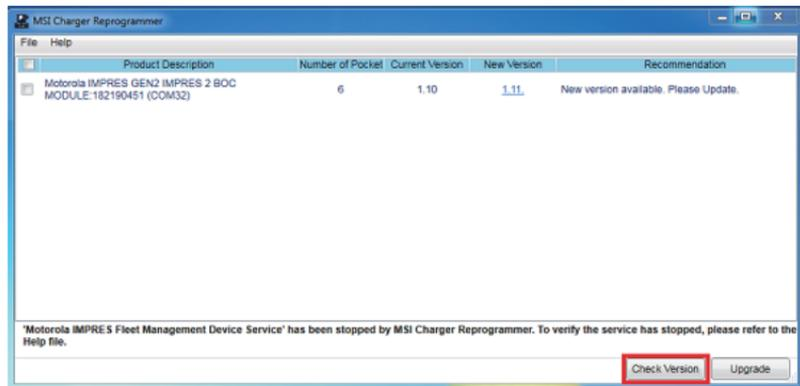

### 3. Selezionare il dispositivo o il caricabatteria da aggiornare.

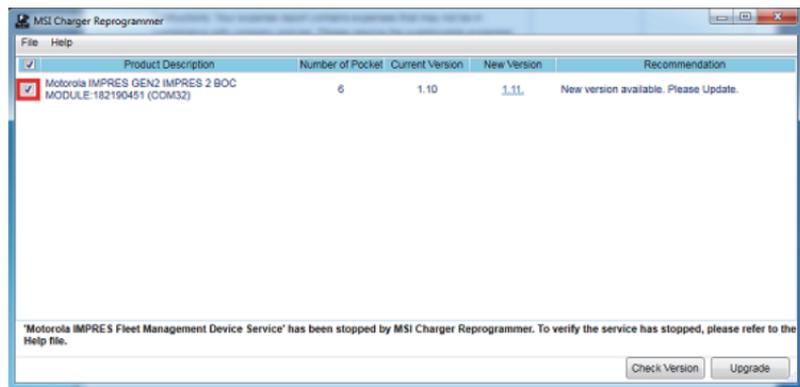

**Nota:** non è possibile selezionare un dispositivo o un caricabatteria già aggiornato con l'ultima versione del firmware.

### 4. Per avviare l'aggiornamento del firmware, fare clic su Aggiorna.

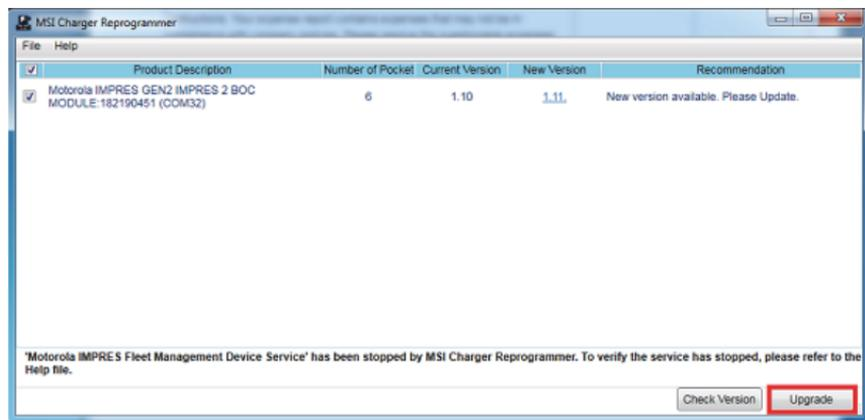

5. Per avviare l'aggiornamento, fare clic su OK nella finestra di conferma quando richiesto. Una finestra mostra lo stato di avanzamento dell'aggiornamento fino al completamento.

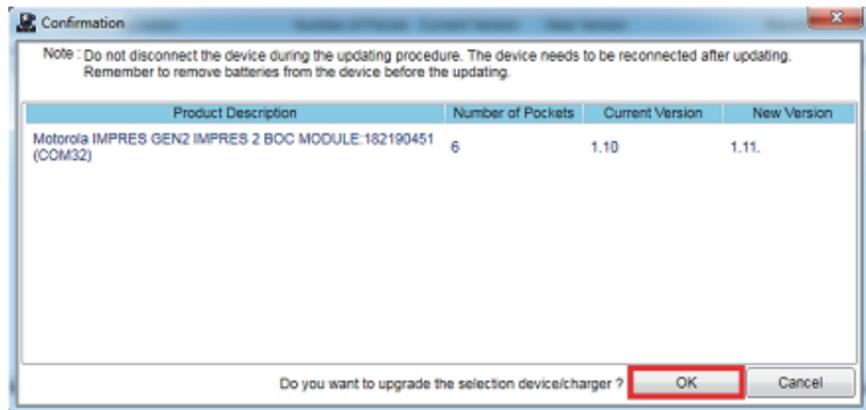

6. Chiudere la finestra una volta completati tutti gli aggiornamenti.

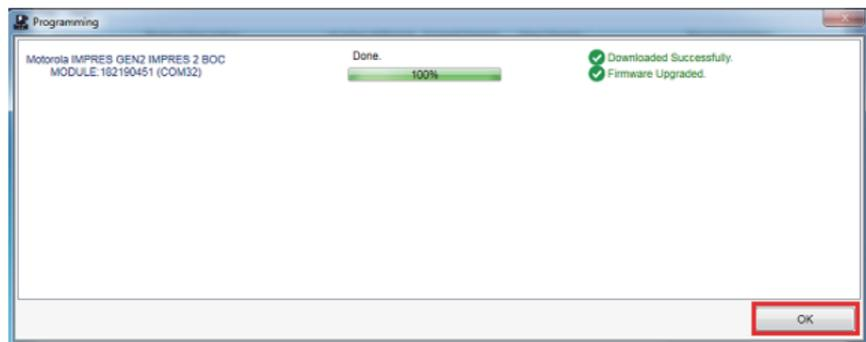



## Avvio manuale del processo di calibrazione/ ricondizionamento



**ATTENZIONE:** la calibrazione manuale o il ricondizionamento non si effettuano nelle batterie IMPRES o IMPRES 2 che presentano questa icona.

Sebbene il processo di calibrazione/ricondizionamento sia automatico, potrebbero verificarsi alcune situazioni in cui è richiesto un avvio manuale. Ad esempio, il caricabatteria potrebbe **alternare i colori ambra/verde** per la batteria IMPRES 2 o IMPRES perché la calibrazione è disabilitata nel caricabatteria. Se nel giro di 30 minuti la batteria viene spostata in un caricabatteria con calibrazione attivata, viene ripreso l'ultimo stato di ricarica, impedendo l'avvio automatico del processo di calibrazione/ricondizionamento.

Per avviare manualmente la calibrazione/il ricondizionamento, rimuovere la batteria IMPRES 2 o IMPRES dal caricabatteria per più di 2 minuti e mezzo. Procedere quindi come segue:

1. Inserire la batteria nel vano del caricabatteria.
2. Entro 2,5 minuti, rimuovere la batteria dal vano di ricarica.
3. Entro 5 secondi, reinserire la batteria nel vano del caricabatteria.

Il processo di calibrazione/ricondizionamento viene avviato immediatamente, in genere quando la batteria viene scaricata (**LED ambra fisso**). Il processo di calibrazione/ricondizionamento è completo solo dopo una ricarica completa (**LED verde fisso**).

## Interruzione manuale del processo di calibrazione/ ricondizionamento

In qualsiasi momento durante lo scaricamento della batteria IMPRES 2 o IMPRES (LED color ambra fisso), è possibile interrompere il processo di calibrazione/ricondizionamento con i seguenti passaggi:

1. Rimuovere la batteria dal vano del caricabatteria.
2. Entro 5 secondi, reinserire la batteria nel vano del caricabatteria.

Lo scaricamento della batteria termina immediatamente e viene avviato il normale processo di ricarica della batteria. Il LED indica lo stato di ricarica.

## Panoramica del caricabatteria

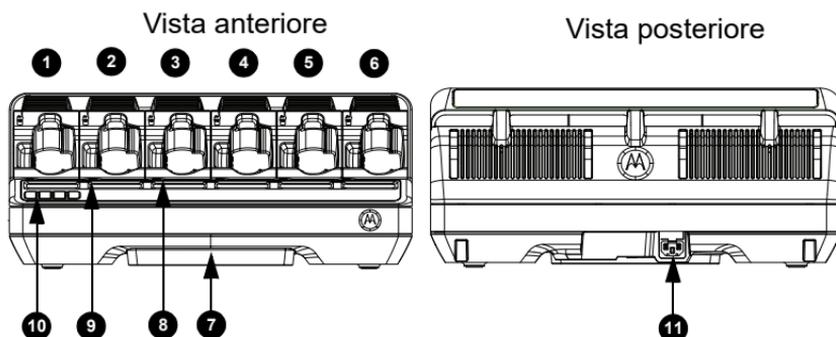

**Figura 1:** Panoramica del caricabatteria

**Tabella 5:** Panoramica e descrizione del caricabatteria

N.	Nome	Descrizione
1-6	Vani del caricabatteria	Ciascun vano può contenere una radio compatibile o una batteria autonoma
7	Modulo di comunicazione	In alcuni caricabatteria, il modulo di comunicazione ricarica anche gli accessori USB: <ul style="list-style-type: none"> <li>• EU/UK PS000029A03</li> <li>• RK PS000029A08</li> </ul>
8	Indicatore di stato LED del vano	LED dello stato di ricarica (uno per ogni vano)
9	Display	Display opzionale per i vani (ad eccezione del vano 1)
10	Display con tastiera	Display associato al vano 1 con tastiera menu
11	Presa di ingresso CA	Utilizza il cavo di alimentazione specifico per il paese o la regione

### Indicatore LED per la fine del ciclo di vita IMPRES 2 o IMPRES

Il caricabatteria potrebbe segnalare la fine del ciclo di vita della batteria IMPRES 2 o IMPRES (**alternanza di rosso e verde**) una volta completato correttamente il processo di calibrazione/ricondizionamento.

Quando le batterie vengono utilizzate, la normale usura riduce la capacità disponibile. Al termine di un processo di calibrazione/ricondizionamento, il caricabatteria confronta la capacità della batteria IMPRES 2 o IMPRES con la capacità nominale della batteria. Se la capacità è molto bassa, è possibile che la batteria IMPRES 2 o IMPRES sia prossima alla fine del ciclo di vita. La batteria IMPRES 2 o IMPRES è comunque utilizzabile. In alcune situazioni, può essere consigliabile dare la batteria a qualcuno che non ha bisogno di un'elevata capacità per completare un turno di lavoro.

La batteria APX NEXT XN è dotata di una funzione di rilevamento delle temperature elevate che funziona con il caricabatteria IMPRES 2 con versione software V2.05 o successive. Quando questa funzione è attivata, il LED di stato lampeggia in rosso e verde alternativamente al termine della carica della batteria che ha subito un'esposizione prolungata in ambienti con temperature estremamente elevate. Sul caricabatteria viene visualizzato quanto segue:

REPLACE BATTERY  
EXPOSED OVERTEMP

Si consiglia di rimuovere la batteria dal servizio.

## Ricarica di batterie o radio con batterie collegate

Le batterie si caricano meglio a temperatura ambiente. I caricabatteria multiunità IMPRES 2 possono ricaricare una batteria autonoma o una batteria collegata a una radio.

1. Posizionare il caricabatteria su una superficie piana.
2. Inserire a fondo il cavo di alimentazione nell'apposita presa di ingresso CA sul retro del caricabatteria.
3. Collegare il cavo di alimentazione a una presa di corrente corrispondente.
4. Dopo l'accensione, tutti i LED dello stato di ricarica diventano **verdi** per un secondo circa e viene visualizzato il messaggio **IMPRES 2 CHARGER**. Se i LED dello stato di ricarica non lampeggiano e non viene visualizzato alcun messaggio, controllare i collegamenti del cavo di alimentazione.

5. Inserire una radio con batteria collegata o una batteria autonoma in un vano disponibile.

**Nota:** tenere il corpo della radio quando la si inserisce o si rimuove dal caricabatteria. Evitare di tirare l'antenna della radio.

6. Quando la radio o la batteria autonoma viene inserita correttamente nel vano, lo stato di ricarica viene indicato dal relativo LED associato. Il display associato fornisce informazioni aggiuntive. Per i caricabatteria a display singolo, il display fornisce lo stato di carica solo del vano 1.
7. La batteria è pronta per l'uso quando il LED dello stato di ricarica è **verde fisso**.
8. Accendere la radio solo quando il modulo di comunicazione del caricabatteria è staccato dal PC. In caso contrario, **SPEGNERE** il dispositivo o la radio.

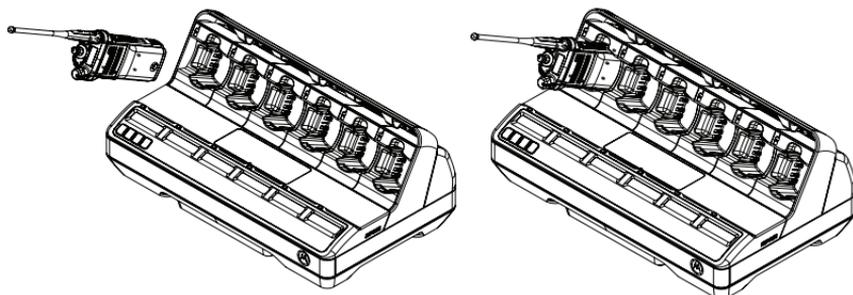

**Figura 2:** Ricarica della batteria collegata alla radio

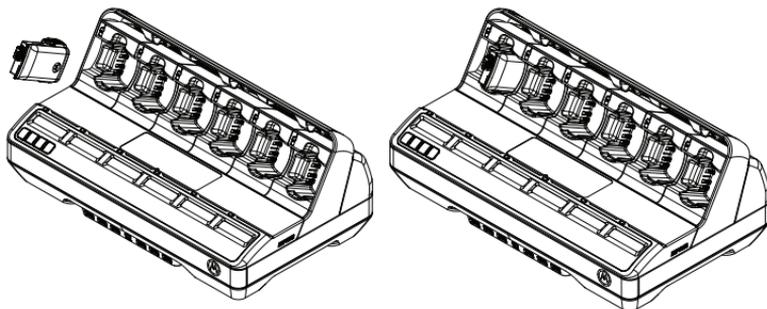

**Figura 3:** Ricarica della batteria autonoma

## Ricarica di accessori USB

Alcuni moduli di comunicazione del caricabatteria multiunità IMPRES 2 forniscono prese di ricarica USB tipo A per ricaricare gli accessori USB. Gli accessori USB si caricano meglio a temperatura ambiente.

1. Posizionare il caricabatteria adattivo IMPRES 2 su una superficie piana.
2. Inserire a fondo il cavo di alimentazione all'apposita presa CA presente sul retro del caricabatteria.
3. Collegare il cavo di alimentazione a una presa di corrente corrispondente.
4. Dopo l'accensione, i LED di stato di tutti i vani diventano **verdi** per un secondo e viene visualizzato il messaggio **IMPRES 2 CHARGER**. Se i LED di stato non lampeggiano e non viene visualizzato alcun messaggio, controllare i collegamenti del cavo di alimentazione.
5. Un accessorio USB può avere una presa micro-AB per la ricarica. Utilizzare un cavo standard di 1 metro o un cavo USB più corto con una presa di tipo A su un'estremità e una presa per gli accessori sull'altra estremità (di solito, Micro-B o Micro-AB).
6. Orientare la presa di tipo A del cavo USB affinché si allinei correttamente a una porta di tipo A sul modulo di comunicazione. Inserire la spina nella porta.
7. Orientare il cavo USB micro-B affinché si allinei correttamente alla presa micro-AB sull'accessorio USB. Inserire la spina nella presa.
8. Quando i collegamenti USB sono stati stabiliti correttamente, lo stato della ricarica viene indicato dall'accessorio USB. Per informazioni, vedere il Manuale dell'utente dell'accessorio USB.

## Indicazioni di ricarica

**Tabella 6:** Indicazioni di ricarica per una batteria IMPRES 2 o IMPRES - Calibrazione non richiesta

Stato	Display del vano	Indicatore LED
Il caricabatteria si accende	IMPRES 2 CHARGER	Verde per circa 1 secondo 
Batteria rilevata	IMPRES 2 BATTERY OPPURE IMPRES BATTERY	Rosso fisso 
Ricarica rapida	RAPID CHARGE XXXX@mAh yy%P t1	Rosso fisso 
Caricata al 90% o più	TRICKLE CHARGE xxxx@mAh yy%P t1	Verde lampeggiante 
Caricata al 95% o più	CHARGE COMPLETE xxxx@mAh yy%P t1	Verde fisso 
Guasto	ATTENZIONE: NOT CHARGEABLE REMOVE & REINSERT	Rosso lampeggiante 
Standby <ul style="list-style-type: none"> <li>• La batteria è in attesa della ricarica rapida.</li> <li>• La batteria è troppo calda, troppo fredda o con bassa tensione.</li> <li>• Il caricabatteria è troppo caldo.</li> </ul>	ATTENZIONE: HOT BATTERY WAITING TO CHARGE OPPURE COLD BATTERY WAITING TO CHARGE OPPURE VERY LOW BATTERY WAITING TO CHARGE OPPURE HOT CHARGER WAITING TO CHARGE	Ambra lampeggiante 

### Nota:

- Il messaggio **Hot Charger** è stato introdotto nella versione 1.05 del software.
- Lo stato delle indicazioni della percentuale di ricarica, relativamente alla capacità potenziale rispetto a quella nominale, è stato introdotto nella versione 1.11.01 del software.

**Tabella 7:** Indicazioni di ricarica per una batteria IMPRES 2 o IMPRES - Calibrazione abilitata

Stato	Display del vano	Indicatore LED
Il caricabatteria si accende	IMPRES 2 CHARGER	Verde per circa 1 secondo 
Batteria rilevata	IMPRES 2 BATTERY OPPURE IMPRES BATTERY	Ambra fisso 
Scaricamento della batteria	CAL DISCHARGE xxxxx@mAh yy.y%P t.1	Ambra fisso 
Ricarica rapida	CAL RAPID CHARGE xxxxx@mAh yy.y%P t.1	Rosso fisso 
Caricata al 90% o più	CAL TRICKLE CHARGE xxxxx@mAh yy.y%P t.1	Verde lampeggiante 
Caricata al 95% o più	<p>Calibrazione della batteria riuscita: Verde fisso </p> <p>La batteria è stata calibrata correttamente, ma si sta avvicinando alla fine del ciclo di vita (è possibile utilizzare la batteria): rosso/verde lampeggiante </p>	
	<p>La batteria è stata calibrata correttamente, ma è stata esposta a una temperatura eccessiva (si consiglia di rimuoverla dal parco batterie): rosso/verde lampeggiante</p> <p>NOTA: applicabile solo alla batteria APX NEXT XN </p>	
Guasto	ATTENZIONE: NOT CHARGEABLE REMOVE & REINSERT	Rosso lampeggiante 

**Tabella 7:** Indicazioni di ricarica per una batteria IMPRES 2 o IMPRES - Calibrazione abilitata (continua)

Stato	Display del vano	Indicatore LED
<p>Standby</p> <ul style="list-style-type: none"> <li>• La batteria è in attesa della ricarica rapida.</li> <li>• La batteria è troppo calda, troppo fredda o con bassa tensione.</li> <li>• Il caricabatteria è troppo caldo.</li> </ul>	<p>ATTENZIONE: HOT BATTERY WAITING TO CAL OPPURE COLD BATTERY WAITING TO CAL OPPURE VERY LOW BATTERY WAITING TO CHARGE OPPURE HOT CHARGER WAITING TO CAL</p>	<p>Ambra lampeggiante</p> 



**Tabella 8:** Indicazioni di ricarica per una batteria IMPRES 2 o IMPRES -  
Calibrazione inizialmente disabilitata e poi abilitata

Stato	Display del caricabatteria	Indicatore LED
Il caricabatteria si accende	IMPRES 2 CHARGER	Verde per circa 1 secondo 
Batteria rilevata	IMPRES 2 BATTERY oppure IMPRES BATTERY	È necessario eseguire la calibrazione della batteria, ma la calibrazione è disattivata nel caricabatteria: alternanza di ambrata e verde per quattro secondi 
È richiesta la calibrazione della batteria IMPRES <ul style="list-style-type: none"> <li>• La calibrazione è disattivata nel caricabatteria.</li> <li>• La batteria si sta ricaricando.</li> </ul>	ATTENZIONE: ENABLE BATTERY CALIBRATION? <ul style="list-style-type: none"> <li>• Premere OK per attivare la calibrazione</li> <li>• Ignorare per eseguire una ricarica normale (il messaggio viene rimosso dopo 1 minuto)</li> </ul>	Rosso fisso 
Scaricamento della batteria <ul style="list-style-type: none"> <li>• OK selezionato</li> </ul>	CAL DISCHARGE xxxxx@mAh yyy%P t1	Ambra fisso 
Ricarica rapida	CAL RAPID CHARGE xxxxx@mAh yyy%P t1	Rosso fisso 
Caricata al 90% o più	CAL TRICKLE CHARGE xxxxx@mAh yyy%P t1	Verde lampeggiante 

**Tabella 8:** Indicazioni di ricarica per una batteria IMPRES 2 o IMPRES -  
Calibrazione inizialmente disabilitata e poi abilitata (continua)

Stato	Display del caricabatteria	Indicatore LED
Caricata al 95% o più	CHARGE COMPLETE xxxxx@mAh yyy%zP t1	Calibrazione della batteria riuscita: Verde fisso   La batteria è stata calibrata correttamente, ma si sta avvicinando alla fine del ciclo di vita (è possibile utilizzare la batteria): rosso/verde lampeggiante 
	REPLACE BATTERY EXPOSED OVERTEMP	La batteria è stata calibrata correttamente, ma è stata esposta a una temperatura eccessiva (si consiglia di rimuoverla dal parco batterie): rosso/verde lampeggiante NOTA: applicabile solo alla batteria APX NEXT XN 
Guasto	ATTENZIONE: NOT CHARGEABLE REMOVE& REINSERT	Rosso lampeggiante 
Standby <ul style="list-style-type: none"> <li>La batteria è in attesa della ricarica rapida.</li> <li>La batteria è troppo calda, troppo fredda o con bassa tensione.</li> <li>Il caricabatteria è troppo caldo.</li> </ul>	ATTENZIONE: HOT BATTERY WAITING TO CAL OPPURE COLD BATTERY WAITING TO CAL OPPURE VERY LOW BATTERY WAITING TO CHRG OPPURE HOT CHARGER WAITING TO CAL	Ambra lampeggiante 

**Tabella 9:** Indicazioni di ricarica per una batteria IMPRES 2 o IMPRES - Calibrazione richiesta, ma non abilitata

Stato	Display del caricabatteria	Indicatore LED
Il caricabatteria si accende	IMPRES 2 CHARGER	Verde per circa 1 secondo 
Batteria rilevata	IMPRES 2 BATTERY oppure IMPRES BATTERY	È necessario eseguire la calibrazione della batteria, ma la calibrazione è disattivata nel caricabatteria: alternanza di ambr e verde per quattro secondi 
È richiesta la calibrazione della batteria IMPRES <ul style="list-style-type: none"> <li>• La calibrazione è disattivata nel caricabatteria.</li> <li>• La batteria si sta ricaricando.</li> </ul>	ATTENZIONE: ENABLE BATTERY CALIBRATION?  <ul style="list-style-type: none"> <li>• Premere OK per attivare la calibrazione.</li> <li>• Ignorare per eseguire una ricarica normale (il messaggio viene rimosso dopo 1 minuto).</li> </ul>	Rosso fisso 
Ricarica rapida <ul style="list-style-type: none"> <li>• Richiesta per la calibrazione scaduta.</li> </ul>	RAPID CHARGE xxxxx@mAh yyy%P t1	Rosso fisso 
Caricata al 90% o più	TRICKLE CHARGE xxxxx@mAh yyy%P t1	Verde lampeggiante 
Caricata al 95% o più	CHARGE COMPLETE xxxxx@mAh yyy%P t1	Alternanza di ambr e verde 
Guasto	ATTENZIONE: NOT CHARGEABLE REMOVE& REINSERT	Rosso lampeggiante 
Standby <ul style="list-style-type: none"> <li>• La batteria è in attesa della ricarica rapida.</li> <li>• La batteria è troppo calda, troppo fredda o con bassa tensione.</li> <li>• Il caricabatteria è troppo caldo.</li> </ul>	ATTENZIONE: HOT BATTERY WAITING TO CHRGE OPPURE COLD BATTERY WAITING TO CHRGE OPPURE VERY LOW BATTERY WAITING TO CHRGE OPPURE HOT CHARGER WAITING TO CHRGE	Ambra lampeggiante 

**Tabella 10:** Indicazioni di ricarica per una batteria IMPRES 2 o IMPRES completamente carica - Calibrazione richiesta, ma non abilitata

Stato	Display del caricabatteria	Indicatore LED
Il caricabatteria si accende	IMPRES 2 CHARGER	Verde per circa 1 secondo 
Batteria rilevata	IMPRES 2 BATTERY oppure IMPRES BATTERY	La batteria è stata caricata completamente negli ultimi 30 minuti e richiede la calibrazione, che, tuttavia, è disabilitata nel caricabatteria: alternanza di ambrata e verde 
Guasto	ATTENZIONE: HOT CHARGEABLE REMOVE& REINSERT	Rosso lampeggiante 
Standby <ul style="list-style-type: none"> <li>• La batteria è in attesa della ricarica rapida.</li> <li>• La batteria è troppo calda, troppo fredda o con bassa tensione.</li> <li>• Il caricabatteria è troppo caldo.</li> </ul>	ATTENZIONE: HOT BATTERY WAITING TO CHRGE OPPURE COLD BATTERY WAITING TO CHRGE OPPURE VERY LOW BATTERY WAITING TO CHRGE OPPURE HOT CHARGER WAITING TO CHRGE	Ambra lampeggiante 

## Altre batterie di Motorola Solutions

**Tabella 11:** Indicazioni di ricarica per altre batterie Motorola Solutions

Stato	Display del caricabatteria	Indicatore LED
Il caricabatteria si accende	IMPRES 2 CHARGER	Verde per circa 1 secondo 
Batteria rilevata	MOTOROLA SOLUTIONS BATTERY	Rosso fisso 
Ricarica rapida	RAPID CHARGE	Rosso fisso 
Caricata al 90% o più	TRICKLE CHARGE	Verde lampeggiante 
Caricata al 95% o più	CHARGE COMPLETE	Verde fisso 
Guasto	ATTENZIONE: NOT CHARGEABLE REMOVE & REINSERT	Rosso lampeggiante 
Standby <ul style="list-style-type: none"> <li>• La batteria è in attesa della ricarica rapida.</li> <li>• La batteria è troppo calda, troppo fredda o con bassa tensione.</li> <li>• Il caricabatteria è troppo caldo.</li> </ul>	ATTENZIONE: HOT BATTERY WAITING TO CHARGE OPPURE COLD BATTERY WAITING TO CHARGE OPPURE VERY LOW BATTERY WAITING TO CHARGE OPPURE HOT CHARGER WAITING TO CHARGE	Ambra lampeggiante 

## Batteria sconosciuta

Alcune batterie sconosciute potrebbero non essere rilevate dal caricabatteria. Le batterie sconosciute non dichiarano i parametri di ricarica in modo riconoscibile al caricabatteria. Se viene rilevata una batteria sconosciuta, il caricabatteria indicherà la ricarica come riportato nella Tabella 12.

**Tabella 12:** Indicazioni di ricarica per batterie sconosciute

Stato	Display del caricabatteria	Indicatore LED
Il caricabatteria si accende	IMPRES 2 CHARGER	Verde per circa 1 secondo 
Batteria rilevata	UNKNOWN BATTERY	Rosso fisso 
Ricarica rapida	RAPID CHARGE	Rosso fisso 
Quasi carica • Capacità della batteria sconosciuta	TRICKLE CHARGE	Verde lampeggiante 
Batteria carica • Capacità della batteria sconosciuta	CHARGE COMPLETE	Verde fisso 
Guasto	ATTENZIONE: NOT CHARGEABLE REMOVE & REINSERT	Rosso lampeggiante 
Standby • La batteria è in attesa della ricarica rapida. • La batteria è troppo calda, troppo fredda o con bassa tensione. • Il caricabatteria è troppo caldo.	ATTENZIONE: HOT BATTERY WAITING TO CHARGE OPPURE COLD BATTERY WAITING TO CHARGE OPPURE VERY LOW BATTERY WAITING TO CHARGE OPPURE HOT CHARGER WAITING TO CHARGE	Ambra lampeggiante 

## Batteria IMPRES 2 o IMPRES per la conservazione a lungo termine

È possibile preparare le batterie Motorola Solutions IMPRES 2 o IMPRES originali e autonome (agli ioni di litio o al nichel) per la conservazione a lungo termine, in un'apposita posizione di stoccaggio, utilizzando un caricabatteria multiunità IMPRES 2. Altri tipi di batterie saranno considerati difettosi. Al completamento della ricarica per la conservazione a lungo termine, se la batteria IMPRES 2 è dotata di una modalità di sospensione, il caricabatteria mette la batteria in questa modalità.

Preparare solo batterie IMPRES o IMPRES 2 per la conservazione a lungo termine. Rimuovere la batteria dalla radio prima di inserirla nel caricabatteria.

NON conservare una batteria autonoma nel caricabatteria. Una volta completata la preparazione per la conservazione a lungo termine, rimuovere immediatamente la batteria dal caricabatteria.

La selezione della conservazione a lungo termine sostituisce la calibrazione/il ricondizionamento. Le batterie al litio preparate per la conservazione a lungo termine potrebbero non soddisfare le normative in materia di trasporto merci per via aerea.

**Tabella 13:** Indicazioni di conservazione a lungo termine di una batteria IMPRES 2 o IMPRES - La batteria è in attesa di essere calibrata

Stato	Display del caricabatteria	Indicatore LED
Il caricabatteria si accende	IMPRES 2 CHARGER	Verde per circa 1 secondo 
Batteria rilevata	IMPRES 2 BATTERY oppure IMPRES BATTERY	La batteria deve essere calibrata: alternanza di ambra e verde per quattro secondi 
Scaricamento della batteria	STORAGE DISCHARGE xxxx% Rated Cap	Ambra fisso 
Ricarica rapida	STORAGE CHARGE xxx% Rated Cap	Rosso fisso 

**Tabella 13:** Indicazioni di conservazione a lungo termine di una batteria IMPRES 2 o IMPRES - La batteria è in attesa di essere calibrata (continua)

Stato	Display del caricabatteria	Indicatore LED
Conservazione a lungo termine completata	LONGTERM STORAGE xxx% Rated Cap	Alternanza di ambra e verde 
<b>Guasto</b> <ul style="list-style-type: none"> <li>• I contatti elettrici tra batteria e caricabatteria non funzionano correttamente.</li> <li>• La batteria non è una batteria IMPRES 2 o IMPRES.</li> <li>• Una condizione sconosciuta sta impedendo lo scaricamento della batteria.</li> <li>• La ricarica viene completata prima di aver completato la conservazione a lungo termine.</li> <li>• Il vano di ricarica è di un tipo speciale.</li> </ul>	<b>ATTENZIONE:</b> NOT CHARGEABLE REMOVE & REINSERT OPPURE WRONG BATT TYPE CANNOT LT STORE OPPURE CANNOT DISCHARGE FOR LT STORAGE OPPURE STORE INCOMPLETE Low Capacity:yy% OPPURE RADIO POCKET CANNOT LT STORE OPPURE CHARGING POCKET CANNOT LT STORE	Rosso lampeggiante 
<b>Standby</b> <ul style="list-style-type: none"> <li>• La batteria è in attesa della ricarica rapida.</li> <li>• La batteria è troppo calda, troppo fredda o con bassa tensione.</li> <li>• Il caricabatteria è troppo caldo.</li> </ul>	<b>ATTENZIONE:</b> HOT BATTERY WAITING TO CHRG OPPURE COLD BATTERY WAITING TO CHRG OPPURE VERY LOW BATTERY WAITING TO CHRG OPPURE HOT CHARGER WAITING TO CHRG	Ambra lampeggiante 

**Nota:**

- I messaggi riportati di seguito sono stati introdotti nella versione software 1.05:
  - Cannot Discharge, for LT Storage
  - Store Incomplete, Low Capacity:yy%
  - Hot Charger, Waiting to Chrg
- I messaggi riportati di seguito sono stati introdotti nella versione software 1.11.01:
  - Wrong Batt Type, Cannot LT Store
  - Radio Pocket, Cannot LT Store
  - Charging Pocket, Cannot LT Store



**Tabella 14:** Indicazioni di conservazione a lungo termine di una batteria IMPRES 2 o IMPRES - Batteria calibrata e da ricaricare fino alla selezione

Stato	Display del caricabatteria	Indicatore LED
Il caricabatteria si accende	IMPRES 2 CHARGER	Verde per circa 1 secondo 
Batteria rilevata	IMPRES 2 BATTERY oppure IMPRES BATTERY	Rosso fisso 
Ricarica rapida	STORAGE CHARGE xxx% Rated Cap	Rosso fisso 
Conservazione a lungo termine completata	LONGTERM STORAGE xxx% Rated Cap	Verde fisso 
<b>Guasto</b> <ul style="list-style-type: none"> <li>• I contatti elettrici tra batteria e caricabatteria non funzionano correttamente.</li> <li>• La batteria non è una batteria IMPRES 2 o IMPRES.</li> <li>• Una condizione sconosciuta sta impedendo lo scaricamento della batteria.</li> <li>• La ricarica viene completata prima di aver completato la conservazione a lungo termine.</li> <li>• Il vano di ricarica è di un tipo speciale.</li> </ul>	<b>ATTENZIONE:</b> HOT CHARGEABLE REMOVE& REINSERT OPPURE WRONG BATT TYPE CANNOT LT STORE OPPURE CANNOT DISCHARGE FOR LT STORAGE OPPURE STORE INCOMPLETE Low Capacity:yy% OPPURE RADIO POCKET CANNOT LT STORE OPPURE CHARGING POCKET CANNOT LT STORE	Rosso lampeggiante 
<b>Standby</b> <ul style="list-style-type: none"> <li>• La batteria è in attesa della ricarica rapida.</li> <li>• La batteria è troppo calda, troppo fredda o con bassa tensione.</li> <li>• Il caricabatteria è troppo caldo.</li> </ul>	<b>ATTENZIONE:</b> HOT BATTERY WAITING TO CHRGE OPPURE COLD BATTERY WAITING TO CHRGE OPPURE VERY LOW BATTERY WAITING TO CHRGE OPPURE HOT CHARGER WAITING TO CHRGE	Ambra lampeggiante 

**Tabella 15:** Indicazioni di conservazione a lungo termine di una batteria IMPRES 2 o IMPRES - Batteria calibrata e da scaricare fino alla selezione

Stato	Display del caricabatteria	Indicatore LED
Il caricabatteria si accende	IMPRES 2 CHARGER	Verde per circa 1 secondo 
Batteria rilevata	IMPRES 2 BATTERY oppure IMPRES BATTERY	Ambra fisso 
Scaricamento della batteria	STORAGE DISCHARGE xxx% Rated Cap	Ambra fisso 
Conservazione a lungo termine completata	LONGTERM STORAGE xxx% Rated Cap	Verde fisso 
<b>Guasto</b> <ul style="list-style-type: none"> <li>• I contatti elettrici tra batteria e caricabatteria non funzionano correttamente.</li> <li>• La batteria non è una batteria IMPRES 2 o IMPRES.</li> <li>• Una condizione sconosciuta sta impedendo lo scaricamento della batteria.</li> <li>• La ricarica viene completata prima di aver completato la conservazione a lungo termine.</li> <li>• Il vano di ricarica è di un tipo speciale.</li> </ul>	<b>ATTENZIONE:</b> HOT CHARGEABLE REMOVE& REINSERT OPPURE WRONG BATT TYPE CANNOT LT STORE OPPURE CANNOT DISCHARGE FOR LT STORAGE OPPURE STORE INCOMPLETE Low Capacity:yy% OPPURE RADIO POCKET CANNOT LT STORE OPPURE CHARGING POCKET CANNOT LT STORE	Rosso lampeggiante 
<b>Standby</b> <ul style="list-style-type: none"> <li>• La batteria è in attesa della ricarica rapida.</li> <li>• La batteria è troppo calda, troppo fredda o con bassa tensione.</li> <li>• Il caricabatteria è troppo caldo.</li> </ul>	<b>ATTENZIONE:</b> HOT BATTERY WAITING TO CHRGE OPPURE COLD BATTERY WAITING TO CHRGE OPPURE VERY LOW BATTERY WAITING TO CHRGE OPPURE HOT CHARGER WAITING TO CHRGE	Ambra lampeggiante 

## Preparazione di una batteria agli ioni di litio per la spedizione

È possibile preparare le batterie IMPRES 2 o IMPRES autonome oppure altre batterie agli ioni di litio Motorola Solutions originali per la spedizione per via aerea utilizzando un caricabatteria multiunità IMPRES 2. Altri tipi di batterie saranno considerati difettosi. Al completamento della ricarica in modalità Ship Lithium, se la batteria agli ioni di litio IMPRES 2 è dotata di una modalità di sospensione, il caricabatteria mette la batteria in questa modalità.

Preparare solo batterie agli ioni di litio Motorola Solutions autonome per la spedizione. Rimuovere la batteria dalla radio prima di inserirla nel caricabatteria.

NON conservare una batteria autonoma nel caricabatteria. Una volta completata la preparazione per la spedizione di batterie al litio, rimuovere immediatamente la batteria dal caricabatteria.

La selezione della spedizione delle batterie agli ioni di litio sostituisce la calibrazione/il ricondizionamento.

### Batteria IMPRES 2 o IMPRES

**Tabella 16:** Indicazioni di stato per una batteria agli ioni di litio preparata per la spedizione - La batteria IMPRES 2 o IMPRES è in attesa di calibrazione

Stato	Display del caricabatteria	Indicatore LED
Il caricabatteria si accende	IMPRES 2 CHARGER	Verde per circa 1 secondo 
Batteria rilevata	IMPRES 2 BATTERY oppure IMPRES BATTERY	La batteria deve essere calibrata: alternanza di ambra e verde per quattro secondi  
Scaricamento della batteria	SHIP LI DISCHARGE xxx% Rated Cap	Ambra fisso 
Ricarica rapida	SHIP LI CHARGE xxx% Rated Cap	Rosso fisso 
Ricarica Ship Lithium completata	LI READY TO SHIP xxx% Rated Cap	Alternanza di ambra e verde  

**Tabella 16:** Indicazioni di stato per una batteria agli ioni di litio preparata per la spedizione - La batteria IMPRES 2 o IMPRES è in attesa di calibrazione (continua)

Stato	Display del caricabatteria	Indicatore LED
<p>Guasto</p> <ul style="list-style-type: none"> <li>• I contatti elettrici tra batteria e caricabatteria non funzionano correttamente.</li> <li>• La batteria è sconosciuta o al nichel.</li> <li>• Una condizione sconosciuta sta impedendo lo scaricamento della batteria.</li> <li>• La ricarica viene completata prima di aver impostato la modalità Ship Lithium.</li> <li>• Il vano di ricarica è di un tipo speciale.</li> </ul>	<p>ATTENZIONE:</p> <p>NOT CHARGEABLE REMOVE&amp; REINSERT OPPURE</p> <p>WRONG BATT TYPE CANNOT SHIP LI OPPURE</p> <p>CANNOT DISCHARGE FOR LI SHIPMENT OPPURE</p> <p>SHIP INCOMPLETE Low Capacity:yy% OPPURE</p> <p>RADIO POCKET CANNOT SHIP LI OPPURE</p> <p>CHARGING POCKET CANNOT SHIP LI</p>	<p>Rosso lampeggiante</p> 
<p>Standby</p> <ul style="list-style-type: none"> <li>• La batteria è in attesa della ricarica rapida.</li> <li>• La batteria è troppo calda, troppo fredda o con bassa tensione.</li> <li>• Il caricabatteria è troppo caldo.</li> </ul>	<p>ATTENZIONE:</p> <p>HOT BATTERY WAITING TO CHARGE OPPURE</p> <p>COLD BATTERY WAITING TO CHARGE OPPURE</p> <p>VERY LOW BATTERY WAITING TO CHARGE OPPURE</p> <p>HOT CHARGER WAITING TO CHARGE</p>	<p>Ambra lampeggiante</p> 

**Nota:**

- I messaggi riportati di seguito sono stati introdotti nella versione software 1.05:
  - Ship LI Discharge, xxx% Rated Capacity
  - Ship LI Charge, xxx% Rated Capacity
  - LI Ready to Ship, xx% Rated Capacity
  - Cannot Discharge, for LI Shipment
  - Ship Incomplete, Low Capacity:yy%
- I messaggi riportati di seguito sono stati introdotti nella versione software 1.11.01:
  - Wrong Batt Type, Cannot Ship LI
  - Radio Pocket, Cannot Ship LI
  - Charging Pocket, Cannot Ship LI

**Tabella 17:** Indicazioni di stato per una batteria agli ioni di litio preparata per la spedizione - Batteria IMPRES 2 o IMPRES calibrata e in attesa di ricarica

Stato	Display del caricabatteria	Indicatore LED
Il caricabatteria si accende	IMPRES 2 CHARGER	Verde per circa 1 secondo 
Batteria rilevata	IMPRES 2 BATTERY oppure IMPRES BATTERY	Rosso fisso 
Ricarica rapida	SHIP LI CHARGE xxx% Rated Cap	Rosso fisso 
Ricarica Ship Lithium completata	LI READY TO SHIP xxx% Rated Cap	Verde fisso 
<b>Guasto</b> <ul style="list-style-type: none"> <li>• I contatti elettrici tra batteria e caricabatteria non funzionano correttamente.</li> <li>• La batteria è sconosciuta o al nichel.</li> <li>• Una condizione sconosciuta sta impedendo lo scaricamento della batteria.</li> <li>• La ricarica viene completata prima di aver impostato la modalità Ship Lithium.</li> <li>• Il vano di ricarica è di un tipo speciale.</li> </ul>	<b>ATTENZIONE:</b> NOT CHARGEABLE REMOVE & REINSERT OPPURE WRONG BATT TYPE CANNOT SHIP LI OPPURE CANNOT DISCHARGE FOR LI SHIPMENT OPPURE SHIP INCOMPLETE Low Capacity:yy% OPPURE RADIO POCKET CANNOT SHIP LI OPPURE CHARGING POCKET CANNOT SHIP LI	Rosso lampeggiante 
<b>Standby</b> <ul style="list-style-type: none"> <li>• La batteria è in attesa della ricarica rapida.</li> <li>• La batteria è troppo calda, troppo fredda o con bassa tensione.</li> <li>• Il caricabatteria è troppo caldo.</li> </ul>	<b>ATTENZIONE:</b> HOT BATTERY WAITING TO CHARGE OPPURE COLD BATTERY WAITING TO CHARGE OPPURE VERY LOW BATTERY WAITING TO CHARGE OPPURE HOT CHARGER WAITING TO CHARGE	Ambra lampeggiante 

**Tabella 18:** Indicazioni di stato per una batteria agli ioni di litio preparata per la spedizione - Batteria IMPRES 2 o IMPRES calibrata e in attesa di scaricamento

Stato	Display del caricabatteria	Indicatore LED
Il caricabatteria si accende	IMPRES 2 CHARGER	Verde per circa 1 secondo 
Batteria rilevata	IMPRES 2 BATTERY oppure IMPRES BATTERY	Ambra fisso 
Scaricamento della batteria	SHIP LI DISCHARGE xxxx% Rated Cap	Ambra fisso 
Ricarica Ship Lithium completata	LI READY TO SHIP xxxx% Rated Cap	Verde fisso 
<b>Guasto</b> <ul style="list-style-type: none"> <li>• I contatti elettrici tra batteria e caricabatteria non funzionano correttamente.</li> <li>• La batteria è sconosciuta o al nichel.</li> <li>• Una condizione sconosciuta sta impedendo lo scaricamento della batteria.</li> <li>• La ricarica viene completata prima di aver impostato la modalità Ship Lithium.</li> <li>• Il vano di ricarica è di un tipo speciale.</li> </ul>	<b>ATTENZIONE:</b> NOT CHARGEABLE REMOVE& REINSERT OPPURE WRONG BATT TYPE CANNOT SHIP LI OPPURE CANNOT DISCHARGE FOR LI SHIPMENT OPPURE SHIP INCOMPLETE Low Capacity:yy% OPPURE RADIO POCKET CANNOT SHIP LI OPPURE CHARGING POCKET CANNOT SHIP LI	Rosso lampeggiante 
<b>Standby</b> <ul style="list-style-type: none"> <li>• La batteria è in attesa della ricarica rapida.</li> <li>• La batteria è troppo calda, troppo fredda o con bassa tensione.</li> <li>• Il caricabatteria è troppo caldo.</li> </ul>	<b>ATTENZIONE:</b> HOT BATTERY WAITING TO CHARGE OPPURE COLD BATTERY WAITING TO CHARGE OPPURE VERY LOW BATTERY WAITING TO CHARGE OPPURE HOT CHARGER WAITING TO CHARGE	Ambra lampeggiante 

## Altre batterie di Motorola Solutions

**Tabella 19:** Indicazioni di stato per una batteria agli ioni di litio preparata per la spedizione - Altre batterie Motorola Solutions

Stato	Display del caricabatteria	Indicatore LED
Il caricabatteria si accende	IMPRES 2 CHARGER	Verde per circa 1 secondo 
Batteria rilevata	MOTOROLA SOLUTIONS BATTERY	Ambra fisso 
Scaricamento della batteria	SHIP LI DISCHARGE xxx% Rated Cap	Ambra fisso 
Ricarica rapida	SHIP LI CHARGE xxx% Rated Cap	Rosso fisso 
Ricarica Ship Lithium completata	LI READY TO SHIP xxx% Rated Cap	Verde fisso 
<b>Guasto</b> <ul style="list-style-type: none"> <li>• I contatti elettrici tra batteria e caricabatteria non funzionano correttamente.</li> <li>• La batteria è sconosciuta o al nichel.</li> <li>• Una condizione sconosciuta sta impedendo lo scaricamento della batteria.</li> <li>• La ricarica viene completata prima di aver impostato la modalità Ship Lithium.</li> <li>• Il vano di ricarica è di un tipo speciale.</li> </ul>	<b>ATTENZIONE:</b> NOT CHARGEABLE REMOVE & REINSERT OPPURE WRONG BATT TYPE CANNOT SHIP LI OPPURE CANNOT DISCHARGE FOR LI SHIPMENT OPPURE SHIP INCOMPLETE Low Capacity:yy% OPPURE RADIO POCKET CANNOT SHIP LI OPPURE CHARGING POCKET CANNOT SHIP LI	Rosso lampeggiante 
<b>Standby</b> <ul style="list-style-type: none"> <li>• La batteria è in attesa della ricarica rapida.</li> <li>• La batteria è troppo calda, troppo fredda o con bassa tensione.</li> <li>• Il caricabatteria è troppo caldo.</li> </ul>	<b>ATTENZIONE:</b> HOT BATTERY WAITING TO CHARGE OPPURE COLD BATTERY WAITING TO CHARGE OPPURE VERY LOW BATTERY WAITING TO CHARGE OPPURE HOT CHARGER WAITING TO CHARGE	Ambra lampeggiante 

## Menu di configurazione del caricabatteria



Svuotare tutti vani del caricabatteria prima di attivare la modalità Charger Setup.

La tastiera del caricabatteria si trova al di sotto del display associato al vano 1.

Per accedere al menu Charger Setup, premere e tenere premuti contemporaneamente i pulsanti freccia sinistra e freccia destra per più tempo rispetto a quello di immissione selezionato (3 secondi, impostazione predefinita).

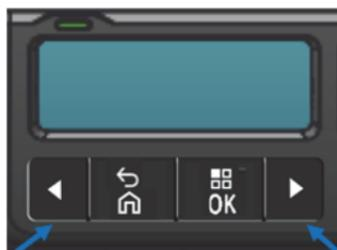

Freccia sinistra

Freccia destra

**Figura 4:** Pulsanti di visualizzazione dei menu per entrare in modalità di configurazione

### Menu principale

Quando si accede al menu Charger Setup, viene visualizzato il seguente messaggio:

```
Press OK to entr  
SETUP MENU
```

Premendo OK, è possibile visualizzare i prompt del menu Charger Setup disponibili.



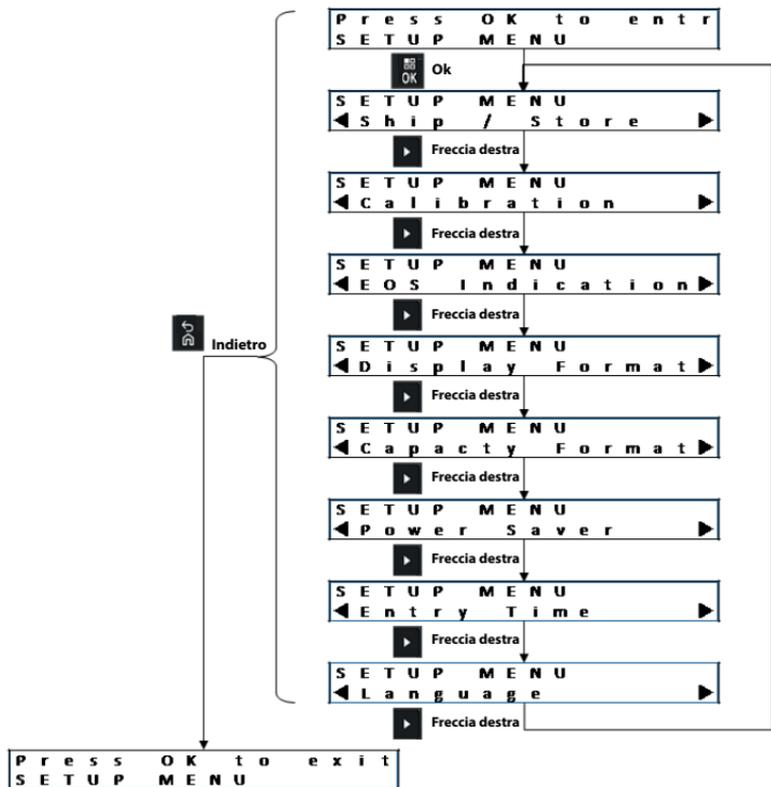

**Figura 5:** Menu di configurazione del caricabatteria

## Selezione del menu di configurazione del caricabatteria

All'interno di ogni selezione del menu Setup:

- Per scorrere le selezioni del menu, premere il pulsante freccia destra.
- Per scorrere le selezioni del menu in ordine inverso, premere il pulsante freccia sinistra.
- Per entrare nel menu selezionato o selezionare l'opzione desiderata, premere OK.

**Nota:** un segno di spunta identifica l'opzione attualmente selezionata.

A partire dalla versione 1.11.01, premere OK per visualizzare il vano successivo sul display del vano 1.

- Per uscire dal menu selezionato, premere Indietro, quindi premere OK per confermare l'uscita.

Se non viene premuto alcun pulsante della tastiera per 10 minuti, il caricabatteria esce dalla modalità Charger Setup e torna alla normale visualizzazione dei messaggi.

Le selezioni del menu Charger Setup vengono memorizzate nella memoria non volatile. Le selezioni non sono interessate dallo spegnimento e della riaccensione del caricabatteria.

## Menu per la spedizione o la conservazione

Sono disponibili quattro opzioni del menu Ship/Storage:

- Disabled
- Ship Lithium-Ion
- Long-Term Storage
- Long-Term Storage (75% Rated Capacity)

Le selezioni Ship Lithium-ion, Long-Term Storage e Long-Term Storage 75% sostituiscono l'impostazione Calibration.



Figura 6: Menu Ship/Storage

## Preparazione della batteria agli ioni di litio per la spedizione

La modalità Ship Lithium imposta lo stato di ricarica di una batteria agli ioni di litio Motorola Solutions su un valore basso consentito per il trasporto di grandi quantità di merci: circa il 25% della capacità nominale.

Alcune batterie Motorola Solutions potrebbero venire scaricate completamente prima di ricaricarle fino al limite consentito dalla modalità Ship Lithium. Tali batterie includono le batterie IMPRES 2 o IMPRES mai calibrate o che necessitano di una nuova calibrazione e altre batterie Motorola Solutions originali, che non sono IMPRES 2 o IMPRES.

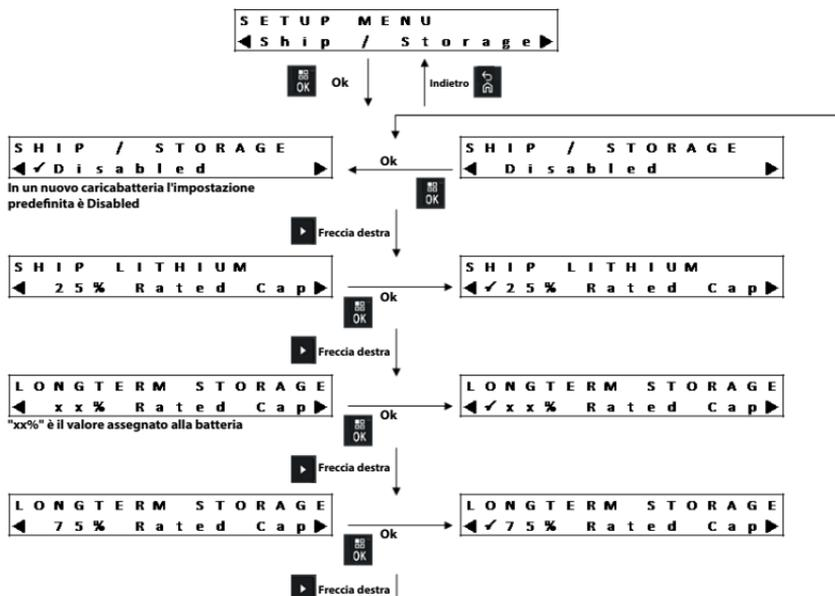
La modalità Ship Lithium si applica solo alle batterie agli ioni di litio Motorola Solutions originali (IMPRES 2, IMPRES o altre batterie agli ioni di litio Motorola Solutions). Le altre batterie (come quelle sconosciute o le batterie Motorola Solutions al nichel o Clamshell) sono considerate difettose.

## Conservazione a lungo termine

L'opzione Long-Term Storage consente di impostare la batteria IMPRES 2 o IMPRES su uno stato di ricarica appropriato quando si conserva la batteria per un lungo periodo di tempo. In genere, lo stato di ricarica preferibile per la conservazione è significativamente inferiore rispetto alla ricarica completa. La selezione  $xx\%$  è un valore programmato nella batteria IMPRES 2 o IMPRES oppure, per impostazione predefinita, è pari al 50% della capacità nominale. L'opzione Long-Term Storage (75% Rated Capacity) è disponibile per i casi in cui si richiede che la batteria conservata abbia uno stato di ricarica più alto, ad esempio per ridurre il tempo per la ricarica completa se la batteria deve essere utilizzata rapidamente o per consentire un periodo di conservazione più lungo.

Alcune batterie IMPRES 2 o IMPRES potrebbero venire scaricate completamente prima di ricaricarle in modalità Long-Term Storage. Si tratta di batterie IMPRES 2 o IMPRES che non sono mai state calibrate o che necessitano di una nuova calibrazione.

L'opzione Long-Term Storage si applica solo alle batterie IMPRES 2 o IMPRES. Le altre batterie (come quelle sconosciute o le batterie Motorola Solutions non IMPRES o Clamshell) sono considerate difettose.

## Batterie IMPRES 2 con modalità di sospensione

Alcune batterie IMPRES 2 sono dotate di una modalità di sospensione. La modalità di sospensione viene utilizzata per prolungare la durata della batteria fino alla ricarica successiva. Al termine della ricarica in modalità Ship Lithium o Long-Term Storage, il caricabatteria mette le batterie in modalità di sospensione.

Se una batteria IMPRES 2 in modalità di sospensione viene inserita in un caricabatteria, si riattiverà. Se la batteria è stata preparata per la modalità Lithium Shipment e viene inserita in un caricabatteria impostato per questa modalità, ritornerà nello stato di sospensione. Se la batteria è stata preparata per la modalità Long-Term Storage e viene inserita in un caricabatteria impostato per questa modalità, ritornerà nello stato di sospensione.

## Menu per la calibrazione

Le selezioni di configurazione del menu Calibration consentono di attivare o disattivare la fase di scaricamento del processo di calibrazione/ricondizionamento. La fase di scaricamento precede la carica completa richiesta per un corretto processo di calibrazione/ricondizionamento. Questa funzione è utile quando il caricabatteria è utilizzato in una posizione in cui la batteria deve essere pronta per l'uso il prima possibile. In queste situazioni, può risultare scomodo attendere lo scaricamento della batteria.

Se una batteria IMPRES 2 o IMPRES è in attesa di calibrazione ed è già scarica quando viene inserita nel caricabatteria, quest'ultimo utilizza il completamento della ricarica come calibrazione per la batteria.



Figura 7: Menu Calibration

## Menu dell'indicatore di fine del ciclo di vita

Anche se la batteria IMPRES 2 o IMPRES è prossima alla fine del ciclo di vita, la relativa capacità può essere più che sufficiente per un uso poco impegnativo. Di conseguenza, potrebbe essere consigliabile disattivare l'indicatore LED per la fine del ciclo di vita (**alternanza di rosso e verde**).

Relativamente alla batteria APX NEXT XN, disattivando questo indicatore si disattiva anche l'indicatore di batteria esposta a temperature elevate per un intervallo di tempo cumulativo.

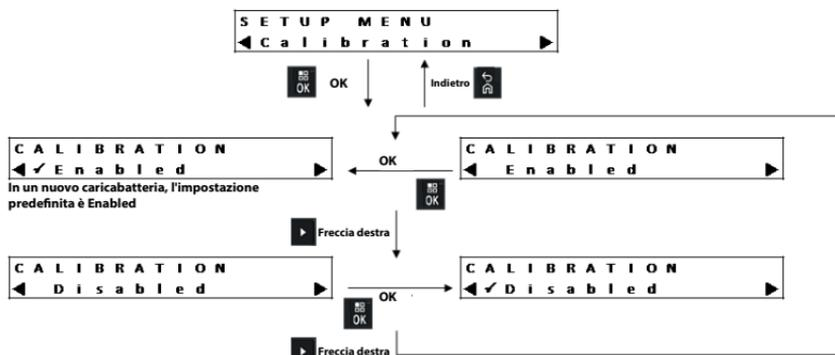
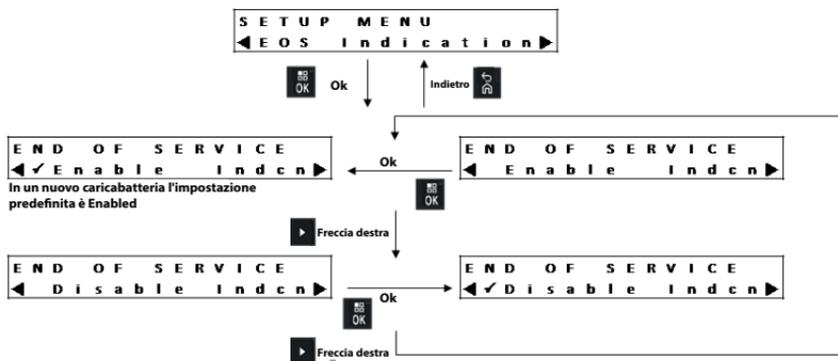

**Figura 8:** Menu Indication (LED) End-of-Service

## Menu del formato display

Il menu Display Format include quattro opzioni:

- Orientamento normale (Normal) (caricabatteria su un tavolo).
- Orientamento invertito (Inverted) (caricabatteria a parete).
- Solo messaggi di attenzione. Altri messaggi non vengono visualizzati. Ciò si applica agli orientamenti Normal e Inverted. I messaggi di attenzione sono identificati dalla Tabella 6 alla Tabella 12.
- Il display è disattivato durante il normale funzionamento. Il display è sempre attivo in modalità Setup e Analyzer.



Figura 9: Menu Display Format

## Menu del formato della capacità

La capacità della batteria viene visualizzata in uno dei vari formati disponibili. Se la capacità della batteria viene visualizzata come percentuale, a quest'ultima ci si riferisce come a una capacità potenziale (carica completa) o nominale. In genere, le radio IMPRES mostrano la percentuale di capacità della batteria in riferimento alla capacità potenziale.

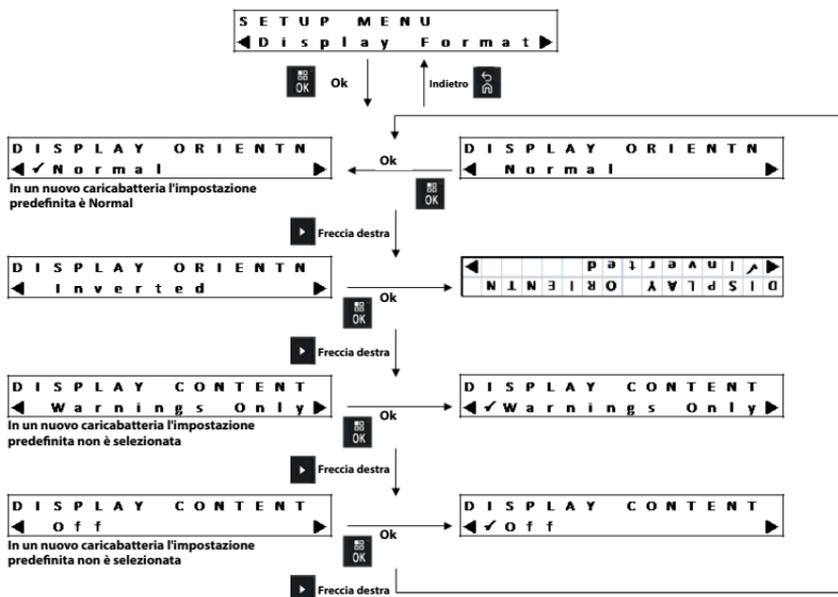

Figura 10: Menu Capacity Format

**Tabella 20:** Opzioni di visualizzazione della capacità della batteria

Rappresentazione	Descrizione
xxx0mAh	Carica attuale (stato di carica) in milliampere.
yyy%	Carica attuale rispetto alla capacità potenziale o nominale, in percentuale. Quando si fa riferimento alla capacità potenziale, il valore massimo è 100%. Quando si fa riferimento alla potenza nominale, il valore massimo può essere superiore al 100%, soprattutto per una nuova batteria.
%BAR	L'equivalente di yyy% rappresentato in una barra a otto segmenti.

## Menu per impostare il risparmio energetico

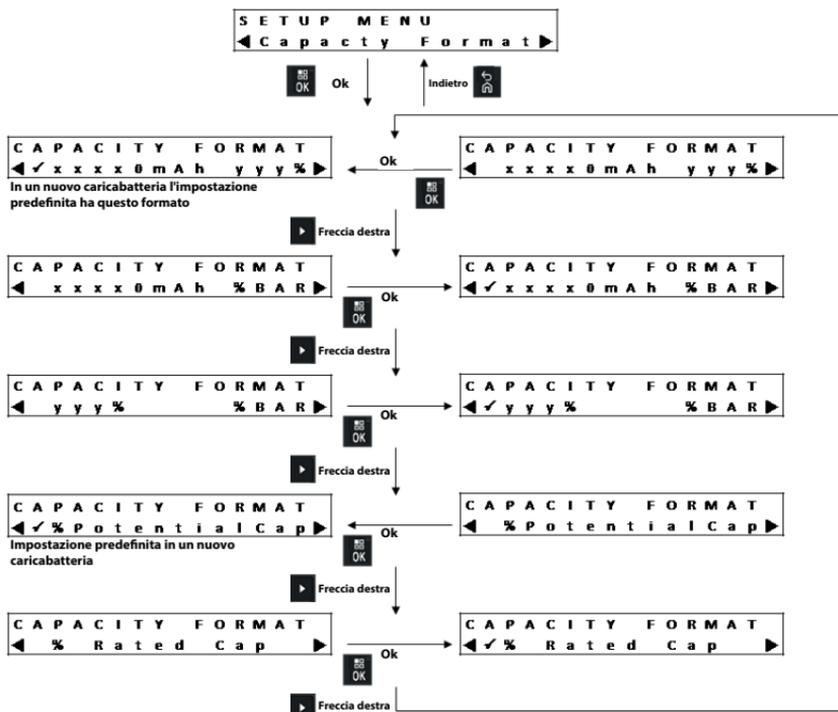
Per rispettare alcuni limiti di bassa alimentazione in standby stabiliti dagli enti governativi, la modalità Power Saver consente al caricabatteria di disattivare tutti i vani, ad eccezione del vano 1, quando non viene rilevata alcuna attività per un determinato periodo di tempo. Di seguito alcuni esempi di attività:

- Ricarica della radio o della batteria.
- Calibrazione/ricondizionamento della batteria.
- Preparazione di una batteria Motorola Solutions agli ioni di litio originale per la spedizione.
- Preparazione della batteria IMPRES 2 o IMPRES per la conservazione a lungo termine.
- Modalità Charger Setup o Analysis.
- Riprogrammazione del caricabatteria.
- Comunicazione con il sistema IMPRES Battery Fleet Management.
- Qualsiasi indicatore LED lampeggiante.

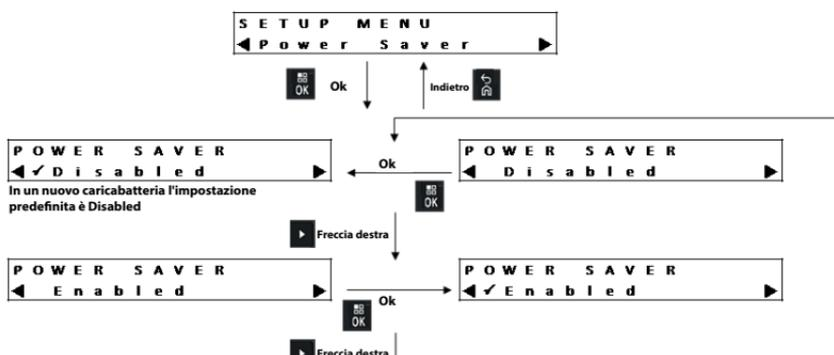
**Figura 11:** Menu Power Saver



Il vano 1 resta attivato, ma in sospensione. Per attivare gli altri vani, premere un pulsante qualsiasi della tastiera. Finché gli altri vani non sono attivati, non possono rispondere all'inserimento o alla rimozione di una radio o batteria.

## Menu che indica il tempo di immissione

Indica il tempo per il quale è necessario tenere premuto il pulsante per accedere alla modalità Charger Setup o Charger Analyzer.



Figura 12: Menu Entry Time

## Menu della lingua

Attualmente, il caricabatteria supporta una lingua: inglese del Nord America.

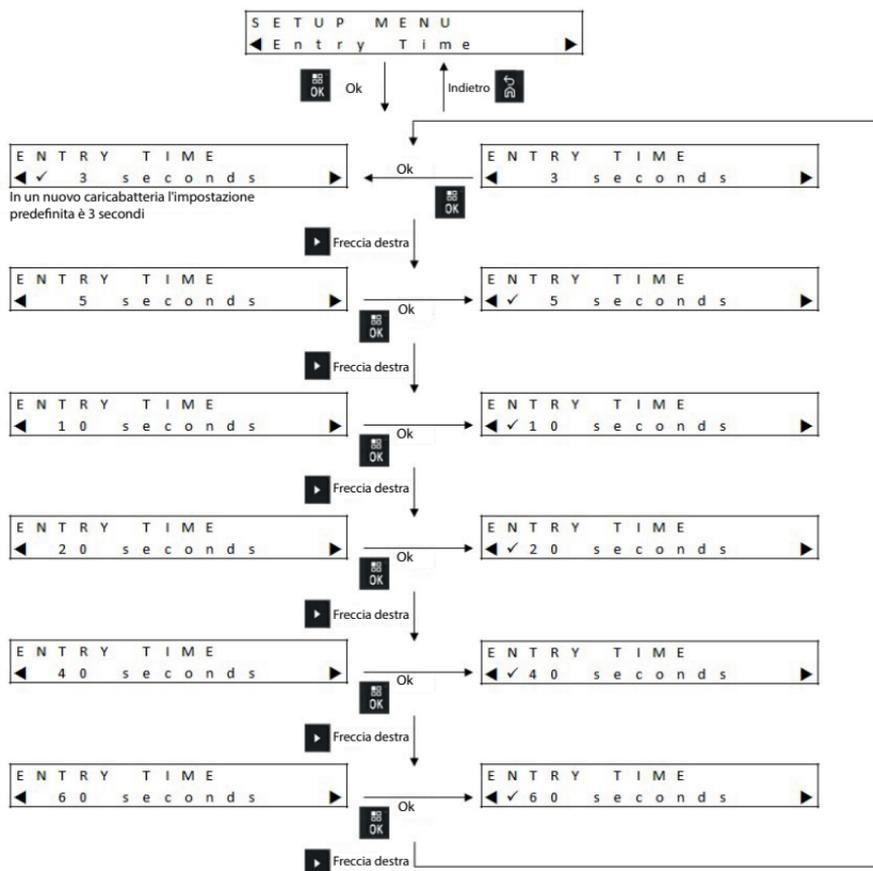
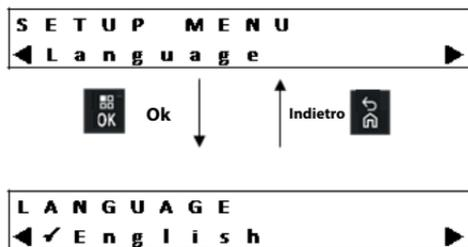

**Figura 13:** Menu Language

## Modalità di analisi

La tastiera del caricabatteria si trova al di sotto del display associato al vano 1.

Per accedere alla modalità Analyzer, premere e tenere premuto il pulsante OK per più tempo rispetto a quello di immissione selezionato (3 secondi, impostazione predefinita).



**Figura 14:** Pulsante di visualizzazione dei menu per entrare in modalità Analyzer

Quando si accede al menu Analyzer, viene visualizzato il seguente messaggio:

```
Press OK to entr
ANALYZER MODE
```

Premendo OK, è possibile visualizzare i prompt con le informazioni disponibili sulla batteria.

## Modalità di analisi nella versione 1.0

Nella versione software 1.0, Analyzer Mode è limitata al vano 1. Le informazioni su Analyzer Mode relativa al vano 1 e al suo contenuto sono visualizzate nel display associato al vano 1. Se non viene premuto alcun pulsante della tastiera per 10 minuti, il caricabatteria esce da Analyzer Mode e torna alla normale visualizzazione dei messaggi.



Figura 15: Menu Analyzer Mode versione 1.0

## Modalità di analisi nella versione 1.05

Analyzer Mode è stata migliorata con il rilascio della versione software 1.05. Per i caricabatteria che prevedono un display per ogni vano, le informazioni di Analyzer Mode vengono visualizzate sul display associato a ogni vano. Quando si scorrono le informazioni di Analyzer Mode per il vano 1, anche gli altri display scorrono le informazioni della modalità Analyzer disponibili per i relativi vani.

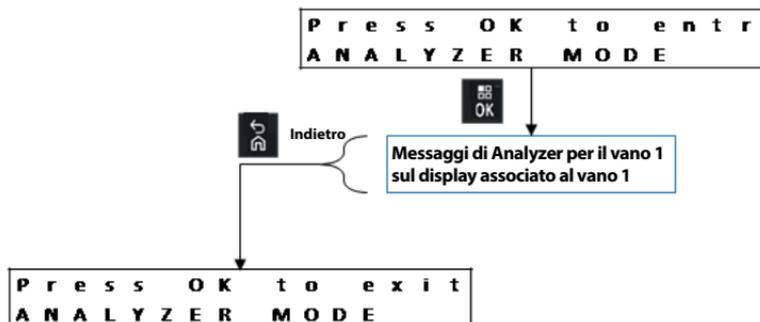

Figura 16: Menu Analyzer Mode versione 1.05



# Batteria IMPRES 2

## Display associato al vano

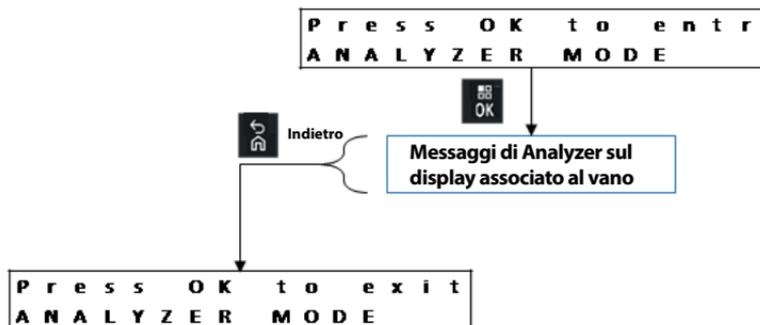

Figura 18: Menu Analyzer Mode della batteria IMPRES 2 per il display associato al vano

## Vano 1 che mostra un altro vano

Il vano xx viene visualizzato nell'angolo in alto a sinistra del display

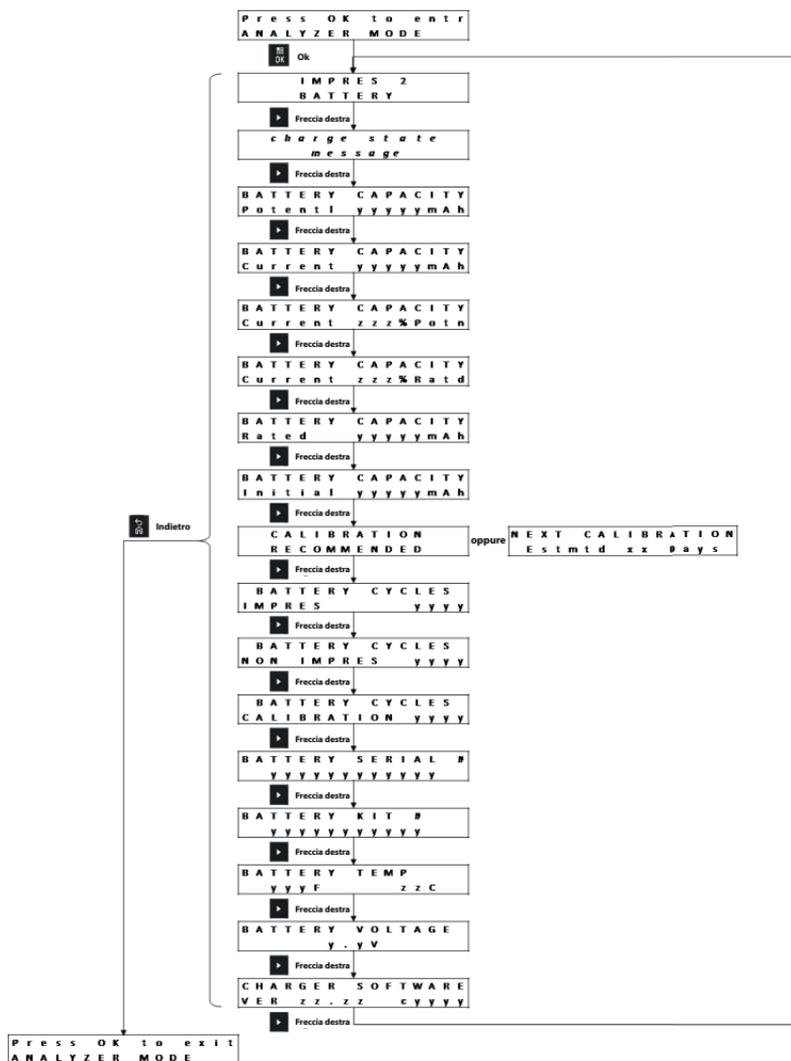

Figura 19: Menu Analyzer Mode della batteria IMPRES 2 per un altro vano (non vano 1)

# Batteria IMPRES

## Display associato al vano

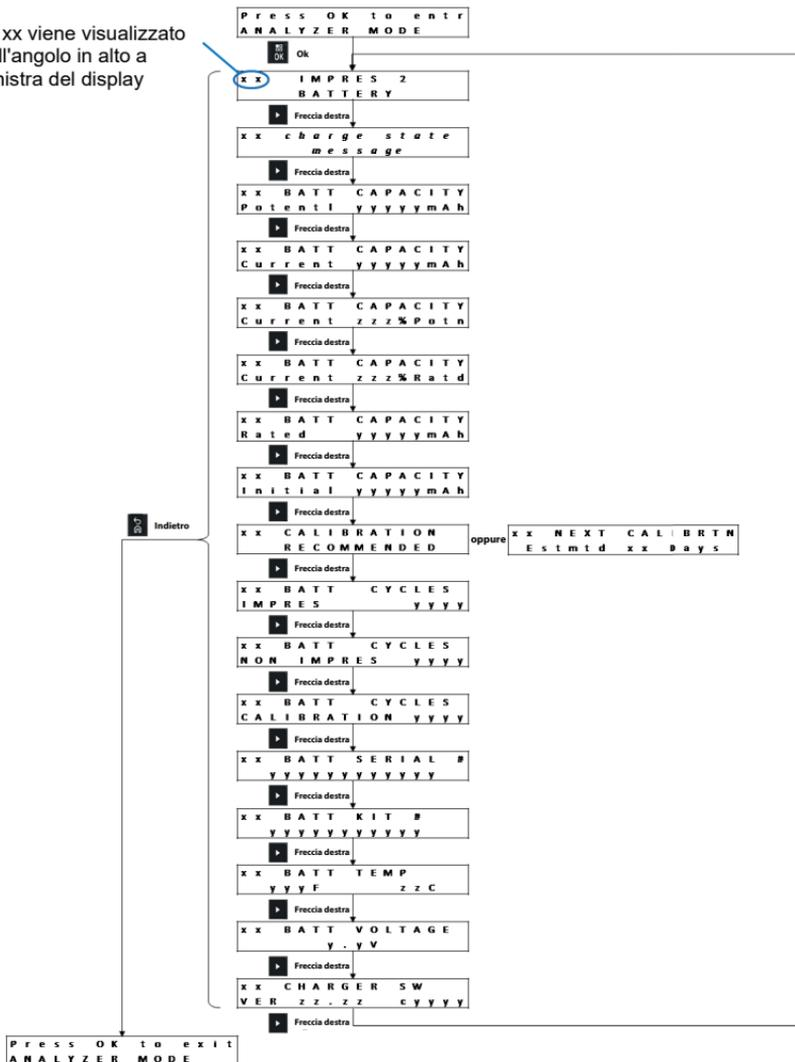

Figura 20: Menu Analyzer Mode della batteria IMPRES per il display associato al vano

## Vano 1 che mostra un altro vano

Il vano xx viene visualizzato nell'angolo in alto a sinistra del display

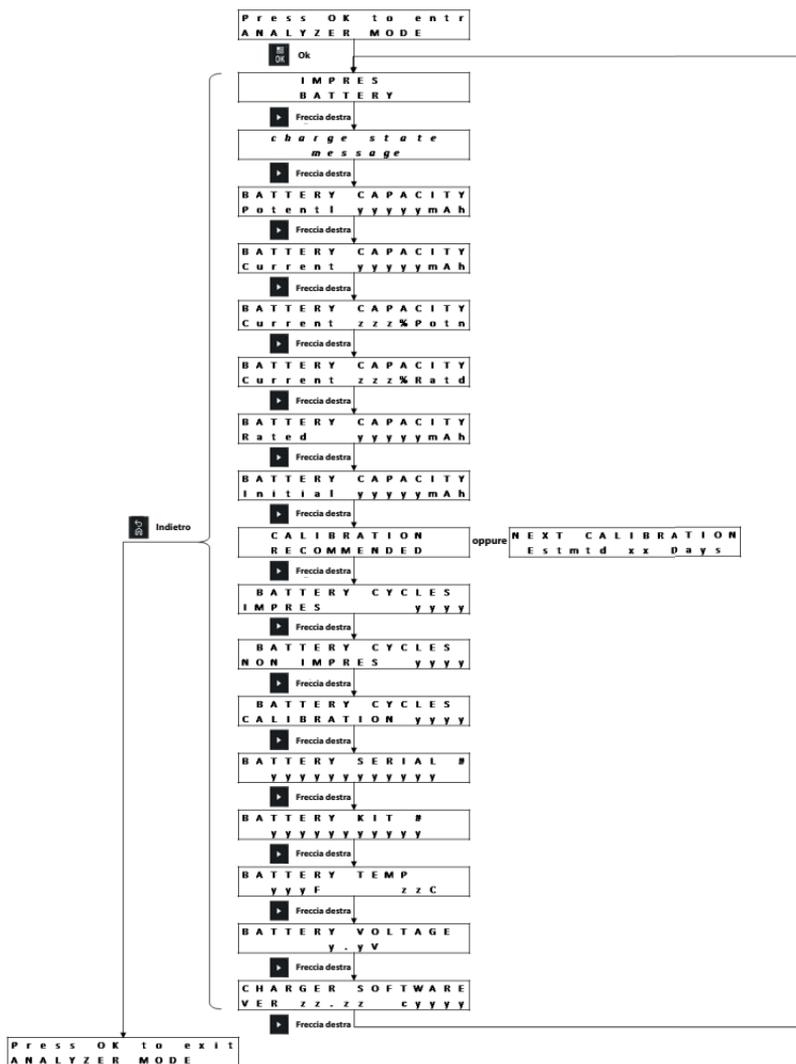

Figura 21: Menu Analyzer Mode della batteria IMPRES per un altro vano (non vano 1)



## Display associato al vano

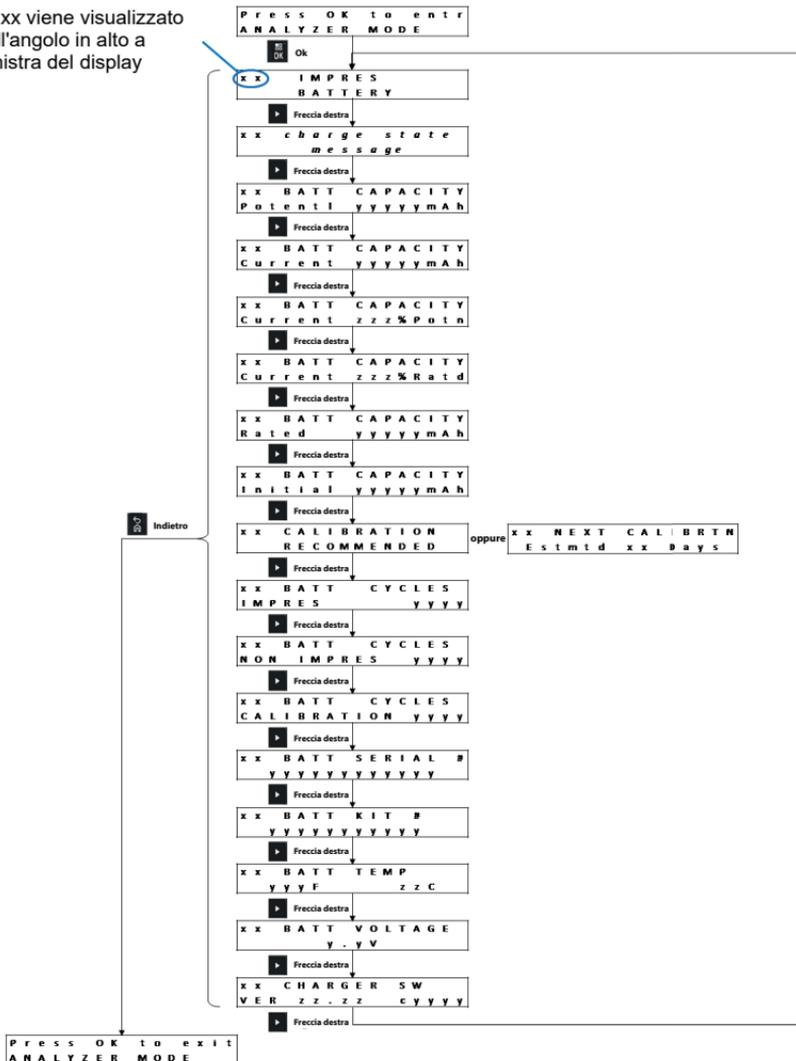
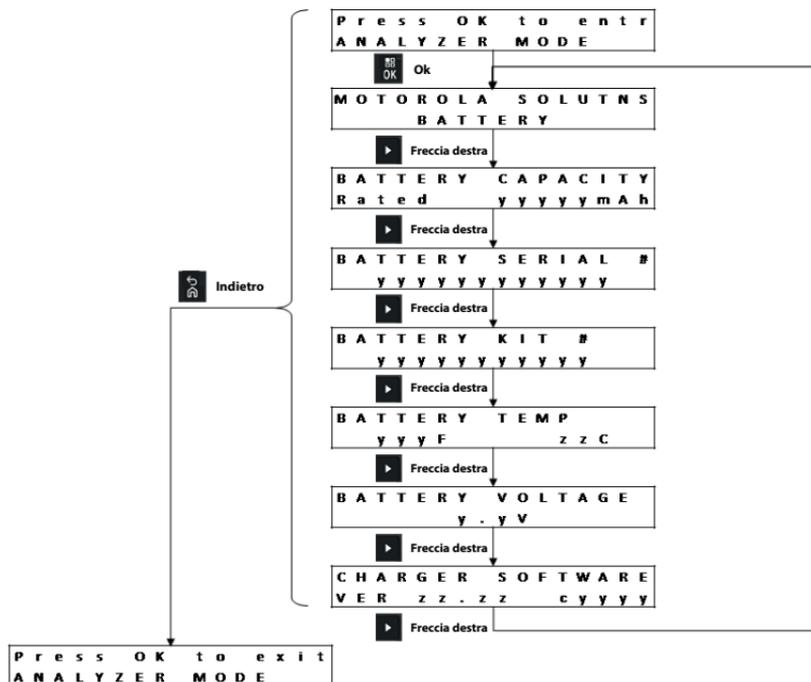

**Figura 22:** Menu Analyzer Mode di altre batterie Motorola Solutions per il display associato al vano

## Vano 1 che mostra un altro vano

Il vano xx viene visualizzato nell'angolo in alto a sinistra del display

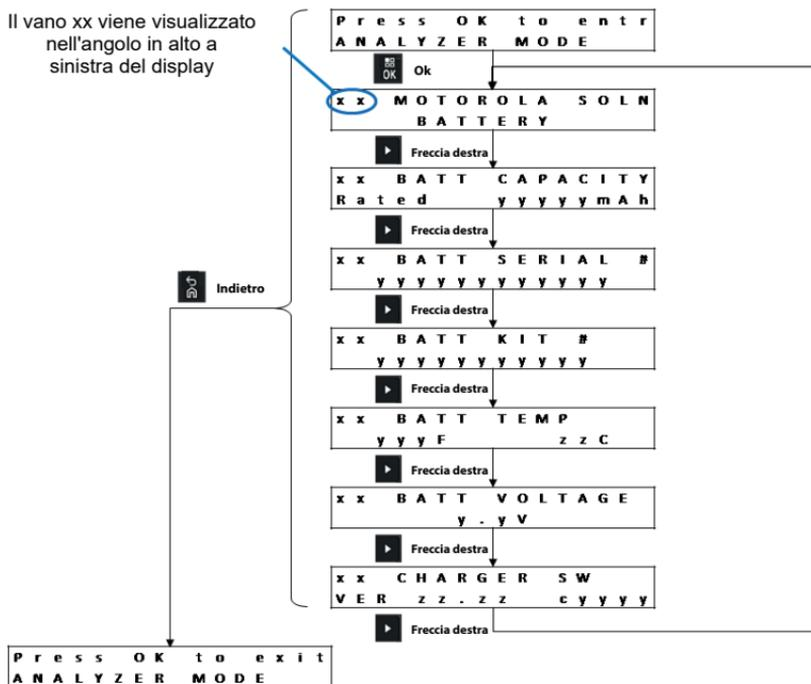

**Figura 23:** Menu Analyzer Mode di altre batterie Motorola Solutions per un altro vano (non vano 1)

## Batteria sconosciuta

### Display associato al vano

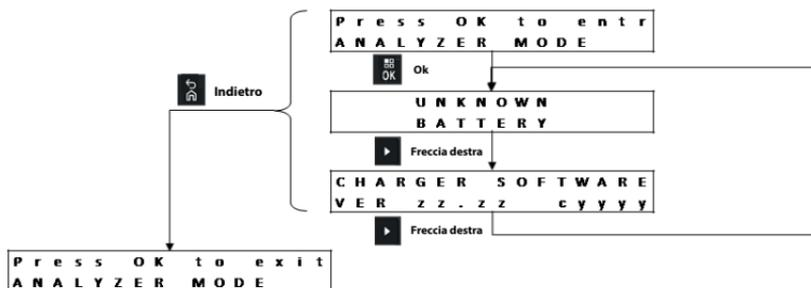

**Figura 24:** Menu Analyzer Mode di una batteria sconosciuta per il display associato al vano

### Vano 1 che mostra un altro vano

Il vano xx viene visualizzato nell'angolo in alto a sinistra del display

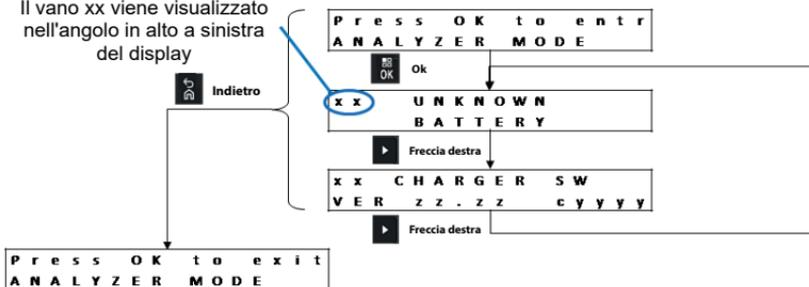

**Figura 25:** Menu Analyzer Mode di una batteria sconosciuta per un altro vano (non vano 1)

## Vano vuoto

### Display associato al vano

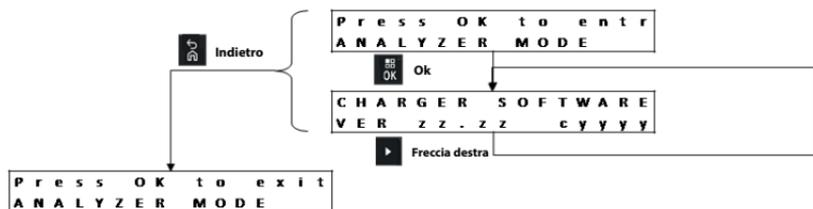

**Figura 26:** Menu Analyzer Mode per un vano vuoto associato al display

### Vano 1 che mostra un altro vano

Il vano xx viene visualizzato nell'angolo in alto a sinistra del display

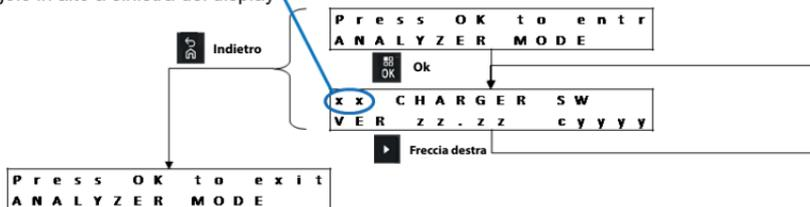

**Figura 27:** Menu Analyzer Mode per un vano vuoto (non vano 1)

## Messaggio di stato del caricabatteria

Alcune batterie IMPRES 2 sono dotate di una modalità di sospensione. Al termine della ricarica Ship Lithium, xx% Long-Term Storage o 75% Long-Term Storage, la batteria entrerà in modalità di sospensione, se abilitata. Il messaggio sullo stato di ricarica, in Analyzer Mode, consente di verificare lo stato di ricarica per le batterie in sospensione.

**Tabella 21:** L'opzione Ship Lithium è abilitata e la batteria ha completato la ricarica Ship Lithium

Display associato al vano	Vano 1 che mostra un altro vano
SHIP LI SLEEP xxx% Rated Cap	xx SHIP LI SLEEP xxx% Rated Cap

**Tabella 22:** L'opzione xx% Long-Term Storage è abilitata e la batteria ha completato la ricarica xx% Long-Term Storage

Display associato al vano	Vano 1 che mostra un altro vano
STORAGE SLEEP xxx% Rated Cap	xx STORAGE SLEEP xxx% Rated Cap

Ad esempio, il messaggio di stato del caricabatteria non viene visualizzato se l'opzione xx% Long-Term Storage è abilitata e la batteria ha completato il 75% di ricarica Long-Term Storage in un altro caricabatteria.

## Riprogrammazione del caricabatteria

La riprogrammazione del caricabatteria richiede che il modulo di comunicazione sia connesso a un computer tramite un cavo USB standard. Quando si utilizza il sistema IMPRES Battery Fleet Management per avviare la riprogrammazione, sul caricabatteria vengono visualizzati i messaggi riportati di seguito.

Rimuovere le batterie dai vani del caricabatteria prima della riprogrammazione:

```
REPROGRAMMING
REMOVE BATTERIES
```

Tutti i vani del caricabatteria sono vuoti:

```
REPROGRAMMING
WAITING FOR DATA
```

È in corso il download dei dati di riprogrammazione:

```
REPROGRAMMING
Progress yyy%
```

Per i caricabatteria con un display associato a ciascun vano, il valore percentuale è la percentuale di dati scaricati correttamente nel vano associato con il display. Per i caricabatteria che hanno un solo display (vano 1), il valore percentuale è la percentuale di dati scaricati correttamente in tutti i vani.

La riprogrammazione non è riuscita nel vano identificato:

```
REPROGRAMMING
POCKET#xx FAILED
```

Il vano del caricabatteria identificato inizia le operazioni normali utilizzando il software precedente.

Il download dei dati di riprogrammazione è completo. La ricarica sta completando il processo di riprogrammazione.

IMPRES 2  
CHARGER

Il processo di riprogrammazione è stato completato correttamente.

REPROGRAMMING  
COMPLETE

Il caricabatteria inizia le operazioni normali utilizzando il software appena scaricato. L'impostazione definita dall'utente viene conservata una volta completata la riprogrammazione del caricabatteria.

# Troubleshooting relativo al caricabatteria

**Tabella 23:** Troubleshooting: ricarica normale

Problema	Azione
<p>Il LED del vano non lampeggia in verde per circa 1 secondo all'accensione del caricabatteria.</p>	<p>Controllare che il cavo di alimentazione sia collegato correttamente al caricabatteria e a una presa elettrica CA appropriata. Assicurarsi che quest'ultima sia alimentata. Controllare i fusibili e, se necessario, sostituirli.</p>
<p>La batteria o la radio è inserita nel vano, ma il LED del vano rimane SPENTO e la batteria non viene identificata sul display associato.</p>	<p>Se il vano non è il n. 1 e la modalità Power Saver è attiva, premere un pulsante di menu. Vedere qui di seguito.</p>
<p>Il LED lampeggia in rosso e il display (se disponibile) visualizza: NOT CHARGEABLE REMOVE&amp; REINSERT oppure la batteria Motorola Solutions è nel vano, ma il display (se disponibile) visualizza: UNKNOWN BATTERY</p> 	<p>Rimuovere la batteria o la radio dal vano. Controllare i contatti elettrici sulla batteria e nel vano del caricabatteria per assicurarsi che siano privi di contaminazione, corrosione o danni fisici. Verificare che la batteria sia autorizzata Motorola Solutions. Non è possibile ricaricare altri tipi di batterie. Pulire i contatti elettrici della batteria con un panno asciutto. Scollegare l'alimentazione dal caricabatteria, quindi pulire i contatti elettrici del vano con un panno asciutto. Provare a sostituire la batteria. Se il guasto scompare, dismettere la batteria difettosa in questione. Se il guasto persiste anche con la batteria di ricambio, dismettere il caricabatteria.</p>
<p>Alternanza tra LED rosso e verde al termine della calibrazione.</p> 	<p>La batteria IMPRES 2 o IMPRES potrebbe essere prossima alla fine del ciclo di vita. La batteria è utilizzabile, tuttavia la capacità disponibile potrebbe non essere adatta all'uso per turni prolungati. Applicabile solo per la batteria APX NEXT XN: la batteria è stata esposta a una temperatura elevata per più di 10 minuti. Si consiglia di rimuoverla dal servizio.</p>

**Tabella 23:** Troubleshooting: ricarica normale (continua)

Problema	Azione
Alternanza tra LED  ambrata e verde per circa 4 secondi al momento dell'inserimento della batteria nel caricabatteria.	La batteria IMPRES 2 o IMPRES necessita di calibrazione/ricondizionamento. Appena possibile, posizionare la batteria in un caricabatteria IMPRES 2 con calibrazione attiva e lasciar completare la calibrazione (verde fisso).
In modalità Analyzer, il vano 1 può visualizzare un altro vano.	Il caricabatteria non è in grado di rilevare il display su almeno uno degli altri vani.

**Tabella 24:** Troubleshooting: ricarica Long-Term Storage

Problema	Azione
Il LED lampeggia in rosso e il display (se disponibile) visualizza: WRONG BATT TYPE CANNOT LT STORE oppure CANNOT DISCHARGE CANNOT LT STORE	Rimuovere la batteria dal vano. Verificare che la batteria NON sia collegata a una radio. Verificare che la batteria sia una batteria IMPRES 2 o IMPRES. Altre batterie saranno considerate difettose. Pulire i contatti elettrici della batteria IMPRES 2 o IMPRES con un panno asciutto. Scollegare l'alimentazione dal caricabatteria, quindi pulire i contatti elettrici del vano con un panno asciutto. Provare a sostituire la batteria con un'altra batteria IMPRES 2 o IMPRES. Se il guasto scompare, dismettere la batteria IMPRES 2 o IMPRES difettosa in questione. Se il guasto persiste anche con la batteria IMPRES 2 o IMPRES di ricambio, dismettere il caricabatteria.
Il LED lampeggia in rosso e il display (se disponibile) visualizza: STORE INCOMPLETE Low Capacity:yy%	La capacità potenziale della batteria IMPRES 2 o IMPRES potrebbe essere inferiore a quella consentita dall'opzione Long-Term Storage. La batteria potrebbe essere prossima alla fine del ciclo di vita.



**Tabella 24:** Troubleshooting: ricarica Long-Term Storage (continua)

Problema	Azione
<p>Il LED lampeggia in rosso e il display (se disponibile) visualizza:</p> <p>RADIO POCKET CANNOT LT STORE</p> <p>oppure</p> <p>CHARGING POCKET CANNOT LT STORE</p>	<p>Il vano di ricarica non è un vano standard per ricaricare una batteria (tramite contatti elettrici tra il caricabatteria e la batteria).</p> <ul style="list-style-type: none"> <li>• Un vano della radio è un vano speciale, in cui la batteria è collegata a una radio, è priva di contatti esterni e viene ricaricata tramite i contatti elettrici sulla radio.</li> <li>• Un vano di ricarica è un vano che utilizza l'energia del caricabatteria per un determinato scopo, come le porte di ricarica USB.</li> </ul> <p>Spostare la batteria in un vano standard o sostituire il vano della radio o di ricarica con un vano standard.</p>

**Tabella 25:** Troubleshooting: ricarica Ship Lithium

Problema	Azione
<p>Il LED lampeggia in rosso e il display (se disponibile) visualizza:</p> <p>WRONG BATT TYPE CANNOT SHIP LI</p>	<p>Rimuovere la batteria dal vano. Verificare che la batteria NON sia collegata a una radio.</p> <p>Verificare che la batteria sia di tipo IMPRES 2 o IMPRES oppure un'altra batteria agli ioni di litio Motorola Solutions autorizzata. Altre batterie saranno considerate difettose.</p> <p>Pulire i contatti elettrici della batteria IMPRES 2 o IMPRES oppure di un altro tipo di batteria agli ioni di litio Motorola Solutions autorizzata con un panno asciutto.</p> <p>Scollegare l'alimentazione dal caricabatteria, quindi pulire i contatti elettrici del vano con un panno asciutto.</p> <p>Provare a sostituire la batteria con un'altra batteria IMPRES 2 o IMPRES oppure un'altra batteria agli ioni di litio Motorola Solutions autorizzata. Se il guasto scompare, dismettere la batteria IMPRES 2 o IMPRES oppure un'altra batteria agli ioni di litio Motorola Solutions autorizzata difettosa in questione.</p> <p>Se il guasto persiste anche con la batteria IMPRES 2 o IMPRES oppure un'altra batteria agli ioni di litio Motorola Solutions autorizzata di ricambio, dismettere il caricabatteria.</p>

**Tabella 25:** Troubleshooting: ricarica Ship Lithium (continua)

Problema	Azione
<p>Il LED lampeggia in rosso e il display (se disponibile) visualizza:</p> <p>SHIP INCOMPLETE Low Capacity:yy%</p>	<p></p> <p>La capacità potenziale di una batteria agli ioni di litio Motorola Solutions originale potrebbe essere inferiore al limite consentito dall'opzione Ship Lithium. La batteria potrebbe essere prossima alla fine del ciclo di vita.</p>
<p>Il LED lampeggia in rosso e il display (se disponibile) visualizza:</p> <p>RADIO POCKET CANNOT LT STORE</p> <p>oppure</p> <p>CHARGING POCKET CANNOT SHIP LI</p>	<p></p> <p>Il vano di ricarica non è un vano standard per ricaricare una batteria (tramite contatti elettrici tra il caricabatteria e la batteria).</p> <ul style="list-style-type: none"> <li>• Un vano della radio è un vano speciale, in cui la batteria è collegata a una radio, è priva di contatti esterni e viene ricaricata tramite i contatti elettrici sulla radio.</li> <li>• Un vano di ricarica è un vano che utilizza l'energia del caricabatteria per un determinato scopo, come le porte di ricarica USB.</li> </ul> <p>Spostare la batteria in un vano standard o sostituire il vano della radio o di ricarica con un vano standard.</p>

## Sistema di gestione del parco batterie IMPRES (Battery Fleet Management)

Il software IMPRES Battery Fleet Management raccoglie automaticamente i dati critici dalle batterie IMPRES o IMPRES 2 inserite in un caricabatteria IMPRES. I dati critici comprendono la durata della batteria, la capacità, la cronologia di ricarica, la cronologia di calibrazione/ricondizionamento, la data di produzione e la data di messa in servizio. Il software IMPRES Battery Fleet Management analizza i dati della batteria, comunica lo stato della batteria e consiglia quando sostituirla. Di conseguenza, è possibile stabilire rapidamente e in modo efficace se riassegnare o meno la batteria a un utente meno esigente, quando acquistare una nuova batteria di ricambio o quando cercare una batteria mancante.

IMPRES Battery Fleet Management fornisce informazioni critiche sulla batteria:

- Indica quando le batterie hanno una capacità inaccettabile.
- Garantisce che gli utenti abbiano a disposizione una capacità sufficiente per un intero turno di lavoro.
- Identifica le batterie con capacità ridotta in modo da rimuoverle.
- Elimina i tempi di inattività e le interruzioni di lavoro impreviste.
- Evita la spesa generata dallo smaltimento prematuro delle batterie.
- Verifica che i caricabatteria siano distribuiti e utilizzati in modo ottimale.

Il software applicativo IMPRES Battery Fleet Management è scalabile da un sistema di rete a sito singolo a un sistema di rete multisito, come illustrato nella Figura 28. Il sistema IMPRES Battery Fleet Management supporta:

- Un server di amministrazione del sistema
- 19 client remoti
- 25 caricabatteria IMPRES o lettori di batterie IMPRES per client
- 25.000 batterie IMPRES nella stessa posizione o in aree geograficamente differenti (il numero totale di batterie per l'intero sistema non può superare i 25.000).

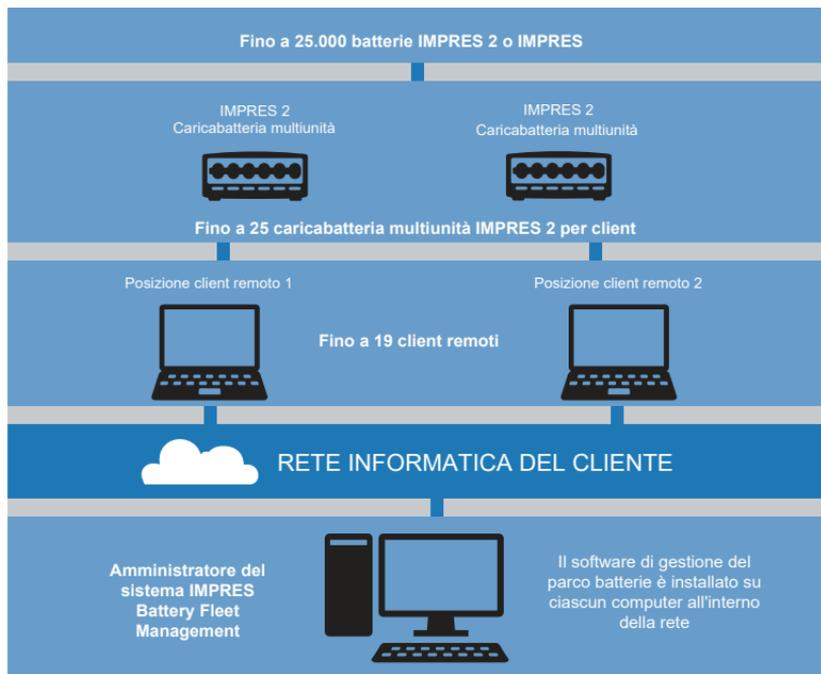

**Figura 28:** Gestione delle batterie IMPRES mediante caricabatteria di rete

IMPRES Battery Fleet Management comprende tre componenti principali:

- Il software applicativo.
- Una chiave di licenza del software.
- Un cavo USB per collegare il caricabatteria IMPRES 2, il modulo di comunicazione IMPRES 2, l'unità di interfaccia per caricabatteria (CIU) IMPRES o il lettore dati batteria IMPRES a un computer che ospita un client remoto.

Utilizzare i report esistenti per personalizzarne di nuovi e vedere le informazioni più rilevanti per la propria organizzazione. I dati vengono memorizzati in un database e possono essere esportati in un file Excel™ o stampati. Il software IMPRES Battery Fleet Management registra e organizza numerosi dati in modo da:

- Visualizzare l'istantanea dello stato dell'intero parco batterie.
- Valutare se le batterie soddisfano i criteri di prestazione.
- Determinare quando le batterie sono prossime al termine del ciclo di vita.
- Decidere esattamente quando acquistare batterie nuove.
- Recuperare un rapporto delle batterie perse.
- Ottimizzare l'utilizzo del caricabatteria.
- Controllare tutti i dispositivi del sistema.

Serial Number	Alias	Group	Radio Family	ID Number	Chemistry	Fmt	Rated Capacity	Potential Capacity	Date of First Use
51000002047478	Sam	Building 1	XTS 3000/3000/2000	HW900118	NCSE	No	1123	1076	8/12/2009
5100000185480	Matt	Security	APR	WNTN7973A	Nature	No	2100	1680	10/11/2008
5100000185488	Inf-lead	Security	APR	WNTN7976A	Nature	Yes	2000	1600	2/14/2007
2000000028253	Phil	Administration	HT1G/PR0 Series	HW900268	NCSE	No	1350	1245	2/4/2008
510000031122	Pete	Building 1	XTS 3000/3000/2000	WNTN4437B	Nature	Yes	1700	1360	8/14/2008
5100000249355	Steve	Building 1	XTS 2500, XTSM/PT/IR 1500	WNTN7654A	Li-Ion	No	2000	1400	8/24/2008
5100000348651	Adam	None	Galve	HW900126	NCSE	No	2000	1600	9/5/2009
5100000348173	Mark	Building 2	XTS 2500, XTSM/PT/IR 1500	WNTN7656A	Li-Ion	No	2000	1440	8/11/2008
5100000382311	Gene	Building 2	XTS 2500, XTSM/PT/IR 1500	WNTN7654A	Li-Ion	No	2000	1440	8/21/2008
5100000384120	Phil	None	Galve	HW900126	NCSE	Yes	2000	1600	10/2/2008
5100000320111	Carol	Administration	HT1G/PR0 Series	HW900268	Nature	Yes	1800	1332	3/11/2009
5100000412807	Paul	Building 1	XTS 3000/3000/2000	WNTN4432B	Nature	Yes	1700	1227	10/21/2008
5100000461360	Ben	Building 1	XTS 3000/3000/2000	HW900118	NCSE	No	1623	1047	8/5/2008
5100000439910	BB	Security	APR	WNTN7973A	Li-Ion	Yes	4000	2811	7/21/2009
5100000439620	Frank	Security	APR	WNTN7973A	Nature	No	2100	1461	12/11/2008
510000041717	Mark	Building 2	XTS 3000/3000/2000	WNTN7433A	Li-Ion	Yes	3900	2804	3/11/2009
510000042338	Eric	Maintenance	MC107T80	PRM9077A	Li-Ion	No	2130	1528	2/18/2009
5100000434708	Henry	Administration	HT1G/PR0 Series	HW900268	NCSE	No	1160	1108	7/10/2009
510000043841	Phil	Building 1	APR	WNTN7973A	Nature	No	2100	1491	5/21/2009
510000040982	Tom	Security	APR	WNTN7973A	Li-Ion	Yes	4000	2911	3/14/2009
510000049127	John	Maintenance	HT1G/PR0 Series	HW900268	NCSE	No	1350	1109	5/21/2009
5100000484221	Steve	Building 2	XTS 3000/3000/2000	PRM9083A	Nature	No	3000	2076	8/6/2007
5100000424188	Paul	Administration	MC107T80	PRM9065A	Li-Ion	Yes	4000	3600	8/12/2008
5100000762123	Frank	Building 1	APR	WNTN7973A	Nature	Yes	2000	1388	3/25/2008
5100000708112	Tom	Security	MC107T80	PRM9069A	Li-Ion	Yes	1400	966	8/12/2007
5100000705013	Henry	Maintenance	APR	WNTN7973A	Nature	No	2100	1446	10/21/2008
510000079458	Scott	Building 2	HT1G/PR0 Series	HW900126	Nature	No	2000	1242	10/12/2007
5100000791386	Steve	Security	XTS 3000/3000/2000	WNTN6144A	Li-Ion	No	4100	2861	8/6/2008
5100000792101	Mark	Administration	APR	WNTN7973A	Nature	No	2100	1446	8/10/2008
5100000797161	Mark	Building 1	MC107T80	PRM9066A	Li-Ion	No	1300	1033	10/11/2007

Figura 29: Report sulle batterie attive



Figura 30: Batterie in uso dalla famiglia di radio





Figura 32: Utilizzo dei vani di ricarica

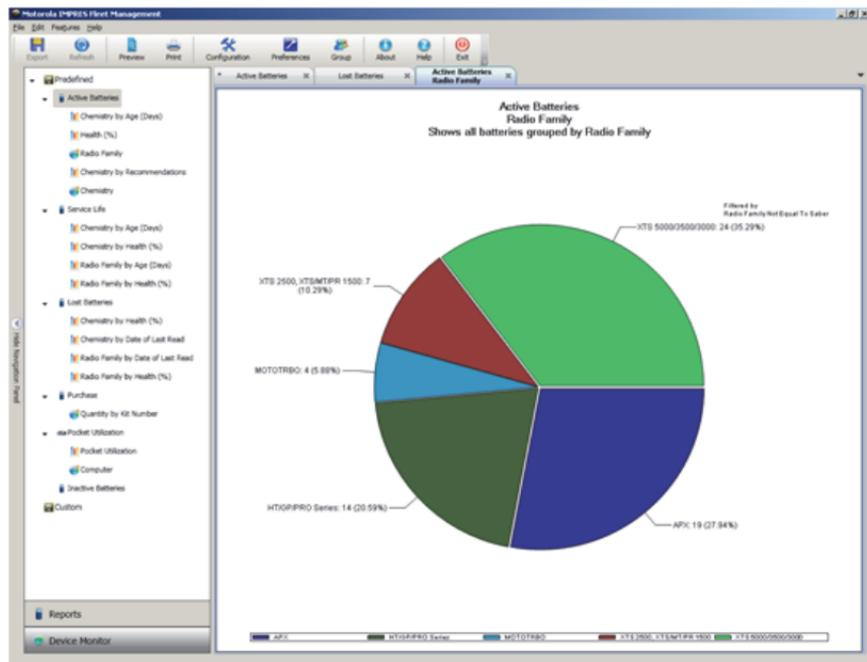

## Montaggio a parete del caricabatteria multiunità

Una staffa per il montaggio a parete (codice prodotto: 0705559L01) è disponibile per il caricabatteria multiunità. Contattare il rivenditore locale per ordinare questo articolo. L'installazione è illustrata di seguito.

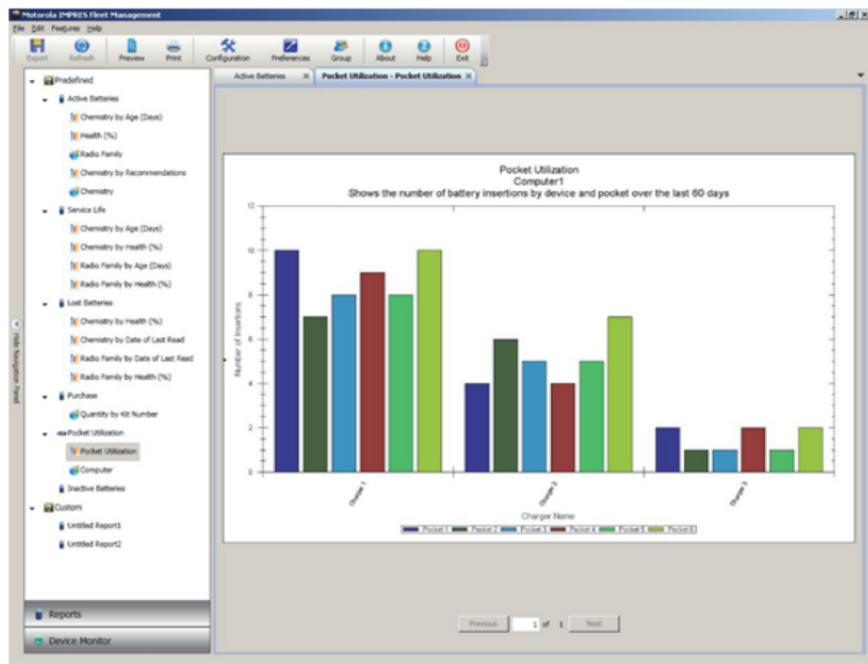

- L'installazione della staffa di montaggio a parete deve essere effettuata da un tecnico esperto. La mancata installazione da parte di un tecnico esperto può risultare pericolosa e provocare danni o lesioni alle persone.
- Non installare il prodotto in una posizione non in grado di sostenerne il peso. Se la posizione in cui viene eseguito il montaggio a parete non è sufficientemente forte, il prodotto potrebbe cadere e causare lesioni alle persone.
- Il prodotto non deve essere installato su una struttura soggetta a vibrazioni o movimenti oppure a rischio di impatti.

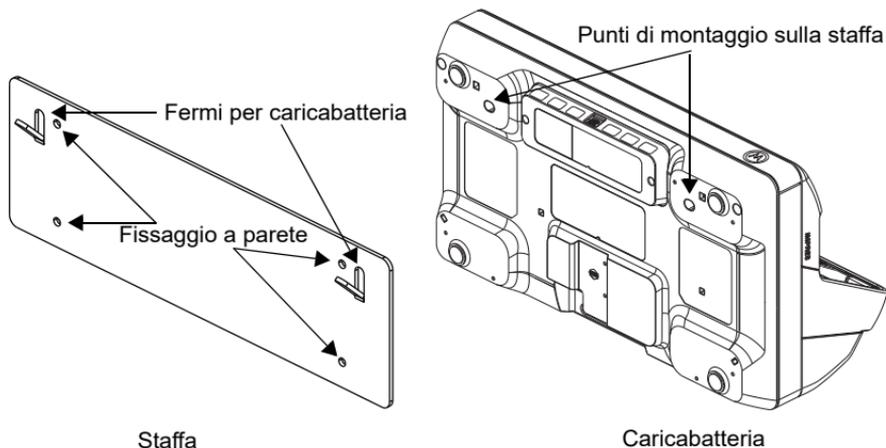

**Figura 33:** Posizione dei fermi e dei fori per staffa di montaggio

## Montaggio del caricabatteria multiunità alla staffa a parete

1. Posizionare la staffa di montaggio a parete nel punto desiderato, quindi segnare la posizione dei fori di montaggio sulla parete.



Prima di perforare la parete o installare le viti di montaggio, assicurarsi che nell'area dietro la superficie di montaggio non siano presenti fili elettrici, cavi e tubazioni.

2. Fissare la staffa alla parete utilizzando gli elementi di montaggio appropriati per il tipo di materiale di cui è composta la parete. Praticare i fori in corrispondenza dei punti di montaggio segnati sulla superficie.
3. Fissare saldamente la staffa di montaggio in posizione utilizzando le apposite viti di montaggio.

**Nota:** si consiglia di utilizzare le viti autofilettanti 10-16x1,5" e rondelle (non incluse) sulle superfici in legno, cemento o mattoni.

4. Agganciare il caricabatteria multiunità alla staffa a parete.

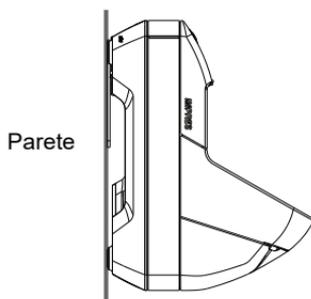

**Figura 34:** Caricabatteria montato sulla staffa a parete

## Note

# BELANGRIJKE VEILIGHEIDSinSTRUCTIES

## Bewaar deze instructies

Dit document bevat belangrijke veiligheids- en gebruiksinstructies. Lees de instructies goed door en bewaar deze voor later gebruik.

Lees alle instructies en waarschuwingen op (1) de oplader, (2) de batterij en (3) de portofoon met de batterij voordat u de batterijoplader gebruikt.



WAARSCHUWING

1. Verminder de kans op schade aan de stroomkabel door de oplader aan de stekker en niet aan de kabel uit het stopcontact te trekken.
2. Gebruik alleen een verlengsnoer als dit absoluut nodig is. Het gebruik van een verkeerd verlengsnoer kan leiden tot brand of een elektrische schok. Als een verlengkabel noodzakelijk is, gebruikt u een kabel met een dikte van 18 AWG bij een lengte tot 2 meter en een kabel met een dikte van 16 AWG bij een lengte tot 3 meter.
3. Verminder de kans op brand, een elektrische schok of letsel door de lader niet te gebruiken als deze op enigerlei wijze defect of beschadigd is. Breng de oplader in dat geval naar een gekwalificeerde Motorola Solutions-servicemonteur.
4. Haal de oplader niet uit elkaar. Als u de oplader uit elkaar haalt, bestaat de kans op een elektrische schok of brand. De enige onderdelen die kunnen worden gerepareerd of vervangen, zijn de Pocket Inserts NNTN9212 en NNTN9213. Volg de instructies in de IMPRES 2™-opladercompartimentinzet uit de APX-serie voor meerdere apparaten MN005697A01.
5. Verminder de kans op een elektrische schok door de stekker van de oplader uit het stopcontact te trekken voordat u deze onderhoudt of reinigt.
6. Verminder de kans op letsel door alleen gebruik te maken van de oplaadbare, door Motorola goedgekeurde batterijen die zijn vermeld in Tabel 2. Andere batterijen kunnen exploderen, waardoor persoonlijk letsel of schade kan ontstaan.

7. Het gebruik van accessoires die niet worden aanbevolen door Motorola Solutions kan leiden tot brand, een elektrische schok of letsel.

## Richtlijnen voor veilige bediening

- De apparatuur is niet geschikt voor gebruik buitenshuis. Gebruik alleen op droge locaties en onder droge omstandigheden.
- De omgevingstemperatuur rondom de lader mag niet hoger zijn dan 40 °C.
- Als de portofoon in een opladercompartiment is geplaatst, kan de portofoon alleen worden ingeschakeld wanneer deze draadloos gegevens verzendt, zoals via Wi-Fi. Als dat niet het geval is, moet u de portofoon uitschakelen.
- Sluit de oplader alleen aan op een geschikte voedingsbron die wordt vermeld in Tabel 3.
- Het stopcontact waarop de stroomkabel wordt aangesloten, moet zich in de buurt bevinden en eenvoudig toegankelijk zijn.
- Zorg ervoor dat de stroomkabel verbonden met de opladers zo ligt dat niemand hierop kan stappen of erover kan struikelen en dat deze niet vochtig kan worden, kan beschadigen of strak kan komen te staan.
- De stroomkabel mag alleen worden aangesloten op een correct bekabeld stopcontact met zekeringen en het juiste voltage, zoals vermeld op het product.
- Onderbreek de stroomtoevoer door de stroomkabel uit het stopcontact te halen.
- Het aantal voedingsbronnen en opladers dat op een gecertificeerde stekkerdoos kan worden aangesloten, is beperkt. Sluit niet meer opladers aan op een circuit van 15 A of 20 A dan zijn toegestaan. U kunt stekkerdozen het beste NIET in serie schakelen. Beperk de circuitbelasting tot onder 80% van de circuitweerstand.
- Gebruik alleen door Motorola Solutions goedgekeurde compartimenten.

## Ondersteunde modellen

**Tabel 1:** Ondersteunde modellen en beschrijving

Model	Beschrijving
PS000029A01 (UNIV) PS000029A04 (EU/VK) PS000029A06 (RK)	IMPRES 2-oplader voor meerdere apparaten met één APX-display, herprogrammering en fleetmanagement
PS000029A02 (UNIV) PS000029A05 (EU/VK) PS000029A07 (RK)	IMPRES 2-oplader voor meerdere apparaten met 6 APX-displays, herprogrammering en fleetmanagement
PS000029A03 (EU/UK) PS000029A08 (RK)	IMPRES 2-oplader voor meerdere apparaten met 6 APX-displays, herprogrammering, fleetmanagement en USB-accessoire voor opladen
PS000337A01 (VS/NA, AU/NZ)	IMPRES 2-oplader voor meerdere apparaten met 6 APX NEXT-displays, herprogrammering en fleetmanagement

Nederlands

## Door Motorola Solutions goedgekeurde batterijen

IMPRES 2-opladers uit de APX-serie laden batterijen op die worden vermeld in Tabel 2. De batterijen zijn mogelijk in de portofoon geplaatst of zijn losse batterijen.

**Tabel 2:** Door Motorola Solutions goedgekeurde batterijen.

Kit (PN)	Beschrijving
NNTN7033	IMPRES lithium-ion FM (HazLoc) IP67 van 4100 mAh
NNTN7034	IMPRES lithium-ion IP67 van 4200 mAh
NNTN7035	IMPRES NiMH FM (HazLoc) Robuust van 2000 mAh
NNTN7036	IMPRES NiMH FM (HazLoc) IP67 van 2000 mAh
NNTN7037	IMPRES NiMH IP67 van 2100 mAh
NNTN7038	IMPRES lithium-ion IP67 van 2900 mAh
NNTN7573	IMPRES NiMH Robuust van 2100 mAh
NNTN8092	IMPRES lithium-ion FM (HazLoc) Robuust van 2300 mAh
NNTN8182	IMPRES lithium-ion Robuust 2900 mAh
NNTN8921	IMPRES 2 lithium-ion TIA4950 (HazLoc) Robuust IP67 van 3700 mAh
NNTN8930	IMPRES 2 lithium-ion TIA4950 (HazLoc) Robuust IP67 van 2700 mAh
NNTN9087	IMPRES 2 lithium-ion IP68 van 3800 mAh

**Tabel 2:** Door Motorola Solutions goedgekeurde batterijen. (vervolg)

Kit (PN)	Beschrijving
NNTN9088	IMPRES 2 lithium-ion DIVISION 2 (HazLoc) IP68 van 3800 mAh
NNTN9089	IMPRES 2 lithium-ion IP68 van 5650 mAh
NNTN9090	IMPRES 2 lithium-ion DIVISION 2 (HazLoc) IP68 van 5650 mAh
NNTN9126	IMPRES 2 lithium-ion IP68 van 4400 mAh
NNTN9127	IMPRES 2 lithium-ion DIVISION 2 (HazLoc) IP68 van 4400 mAh
PMNN4403	IMPRES lithium-ion IP67 van 2150 mAh
PMNN4485	IMPRES 2 lithium-ion Robuust IP67 van 2500 mAh
PMNN4486	IMPRES 2 lithium-ion Robuust IP67 van 3400 mAh
PMNN4487	IMPRES 2 lithium-ion Robuust IP67 van 4400 mAh
PMNN4494	IMPRES 2 lithium-ion Robuust IP67 van 5000 mAh
PMNN4504	IMPRES 2 lithium-ion DIVISION 2 (HazLoc) Robuust IP67 van 3400 mAh
PMNN4505	IMPRES 2 lithium-ion DIVISION 2 (HazLoc) Robuust IP67 van 4850 mAh
PMNN4547	IMPRES 2 lithium-ion TIA4950 (HazLoc) Robuust IP68 van 3100 mAh
PMNN4573	IMPRES 2 lithium-ion TIA4950 (HazLoc) Robuust IP68 van 4600 mAh
PMNN4812	APX NEXT XN IMPRES 2 lithium-ion DIV 2 (HAZLOC) IP68 3400 mAh

## Door Motorola Solutions goedgekeurde voedingsaccessoires

**Tabel 3:** Door Motorola Solutions goedgekeurde voedingsaccessoires

Kit (PN)	Beschrijving
3087791G01	Stroomkabel, VS/NA
3087791G04	Stroomkabel, EU
3087791G07	Stroomkabel, VK/HK
3087791G10	Stroomkabel, AU/NZ
3087791G13	Stroomkabel, AR
3087791G16	Stroomkabel, KR
3087791G20	Stroomkabel, JP
3087791G22	Stroomkabel, BR
CB000460A01	Stroomkabel, CH

# Door Motorola Solutions goedgekeurde communicatiemodules

**Tabel 4:** Door Motorola Solutions goedgekeurde communicatiemodules

Kit (PN)	Beschrijving
AS000013A01	IMPRES 2-opladerherprogrammerings- en batterij-fleetmanagementmodule
AS000012A02	IMPRES 2-opladerherprogrammerings- en batterij-fleetmanagement- en accessoire-oplaadmodule

## Oplader, compartiment en communicatiemodule

Het IMPRES 2™ Adaptive-ladersysteem uit de APX-serie is een volledig geautomatiseerd batterijonderhoudssysteem. De oplader is voorzien van de volgende functies:

- Adaptief opladen om het laden van een grote verscheidenheid batterijtypen mogelijk te maken, inclusief IMPRES 2, IMPRES™ en andere originele Motorola Solutions-batterijen.
- Compartiment met ruimte voor een portofoon met een bevestigde batterij of een losse batterij.
- Rode/oranje/groene LED geeft de status van het ladercompartiment aan.
- Communicatiemodule
  - Herprogrammering van de oplader
  - Uploaden van IMPRES2- of IMPRES-batterijgegevens naar een IMPRES-batterij-fleetmanagementsysteem
  - (Optioneel) Zes USB-oplaadpoorten van type A, elk met 0,5 A voor het opladen van een USB-accessoire
- Toetsenblokmenu
  - Oplader instellen
  - Batterij-analyse
- Informatiedisplay op compartiment 1.
  - Optionele displays op andere compartimenten
- Voorbereiding van een losse IMPRES 2- of IMPRES-batterij op langdurige opslag of voorbereiding van een losse Motorola Solutions lithium-ion batterij op verzending. Laat de batterijen NIET achter in de oplader na ze te hebben voorbereid op langdurige opslag of lithium-ion verzending.



- Functies voor efficiënt energiegebruik
  - Voldoet aan de apparaatnormen van de California Energy Commission voor kleine batterijopladersystemen. De ladercompartimenten gaan automatisch in slaapstand en worden vervolgens wakker als reactie op een gebruikersactie of om een batterij in het compartiment te laden.
  - Voldoet aan de Europese stand-bystroomlimieten (Europese opladerset). Als de energiezuinige modus is ingeschakeld, schakelen alle ladercompartimenten, behalve Compartiment 1, automatisch uit als er gedurende een bepaalde tijd geen activiteit is. Door op een willekeurige toets van het toetsenblok te drukken, worden deze compartimenten weer ingeschakeld.
- Sneller opladen IMPRES 2-lithium-ionbatterij.
- Sneller opladen.
- Verlengde levensduur van de batterij.

Het gebruik van een portfoon in de oplader wordt niet aanbevolen.

Tijdens het laden kan de portfoon iets minder goed werken en bij portfoongebruik kan het laadproces langer duren.

Tijdens het kalibreren/reviseren wordt de batterij geheel ontladen voordat deze weer volledig wordt opgeladen. Als gevolg hiervan kan de portfoon tijdens het ontladen uitvallen. Het wordt aanbevolen dat u de batterij kalibreert zonder dat de portfoon is aangesloten of met de aangesloten portfoon uitgeschakeld.

## **IMPRES 2- en IMPRES-batterijen en -opladers**

### **Functies en voordelen**

De IMPRES 2-stroomoplossing is een geavanceerd Tri-Chemistry-energiesysteem ontwikkeld door Motorola Solutions. Dit systeem omvat:

- IMPRES 2- en IMPRES-batterijen
- IMPRES Adaptive-oplader
- IMPRES-portfoons

Opladen van IMPRES 2- of IMPRES-batterijen met een IMPRES Adaptive-oplader die regelmatig de batterij kalibreert/reviseert, levert de volgende voordelen op:

- Verlengt de levensduur van de batterij.
- Meet de batterijcapaciteit en bepaalt de huidige oplaadstatus van de batterij, voor een indicatie van effectieve gebruiksduur.
- Bewaakt het gebruikspatroon van de IMPRES 2- of IMPRES-batterij.
- Werkt patrooninformatie bij die is opgeslagen in de IMPRES 2- of IMPRES-batterij.
- Voert automatisch een kalibratie/revisie uit als dat nodig is.
- Minimaliseert opwarmen van de IMPRES 2- of IMPRES-batterij, ongeacht hoe lang de batterij zich in het compartiment bevindt.
- Zorgt voor regelmatig 'aftoppen' van een batterij die zich in het compartiment van de oplader bevindt en zorgt zo voor vrijwel permanente paraatheid voor de gebruiker.
- Elimineert het geheugeneffect van de nikkelbatterij zodat de aanschaf van speciale apparatuur of het trainen van personeel voor taken met betrekking tot het levenscyclusonderhoud van de batterij niet nodig is.

Dankzij dit unieke gepatenteerde systeem is het niet nodig om het gebruik van de IMPRES 2- of IMPRES-batterijen bij te houden of te documenteren, om handmatig te kalibreren/reviseren of om na het opladen de batterijen uit de opladers te halen.

## Initialisatie IMPRES 2- of IMPRES-batterij

Voor volledige IMPRES 2- of IMPRES-functionaliteit moet er een nieuwe IMPRES 2- of IMPRES-batterij worden geïnitieerd door de lader. De oplader detecteert automatisch de nieuwe IMPRES 2- of IMPRES-batterij en begint automatisch met het initialiseren. De initialisatie is de eerste kalibratie/revisie van een IMPRES 2- of IMPRES-batterij. Dit proces bestaat uit twee fasen. De eerste fase is het ontladen van de batterij, aangeduid met een **onafgebroken oranje** LED. De tweede fase is volledig opladen, uiteindelijk aangeduid met een **onafgebroken groene** LED. Dit proces kan 12 uur of langer duren, afhankelijk van de oplaadstatus en de capaciteit van de batterij. Onderbreking van één van beide fasen stelt de initialisatie uit tot de volgende oplaadgelegenheid.

## IMPRES 2 of IMPRES Pocket-to-Pocket

Tijdens het opladen van IMPRES 2- of IMPRES-batterijen neemt de IMPRES 2- of IMPRES-oplader informatie op in het batterijgeheugen. Als de IMPRES 2- of IMPRES-batterij wordt verwijderd uit een IMPRES 2- of IMPRES-opladercompartiment en binnen 30 minuten in een ander of hetzelfde IMPRES 2- of IMPRES-opladercompartiment wordt geplaatst, wordt het opladen hervat op het punt waar het was onderbroken. Deze functie voorkomt overbelading van de batterij en vermindering van levensduur. Dit is vooral belangrijk bij het opladen van nikkelbatterijen.

## Automatische kalibratie/revisie van IMPRES 2- of IMPRES-batterij

De IMPRES 2-oplader van de APX-serie evalueert automatisch de toestand van een IMPRES 2- of IMPRES-batterij. Op basis van deze toestand kalibreert/revisieert de oplader de batterij automatisch. Onderbreking van de ontladefase of de volledige oplaadfase stelt de kalibratie uit tot de volgende oplaadgelegenheid.

Gebruik de instellingsmodus oplader om kalibratie/revisie in of uit te schakelen. Als deze optie is uitgeschakeld en de IMPRES 2- of IMPRES-batterij moet worden gekalibreerd/gereviseerd, brandt het lampje **afwisselend oranje/groen** bij plaatsing van de batterij en nadat de batterij is opgeladen.

**Opmerking:** Voor een automatische kalibratie/revisie moet de IMPRES 2- of IMPRES-batterij zich langer dan 30 minuten buiten het opladercompartiment bevinden.

## IMPRES-batterij met zelfkalibratie en revisie



**LET OP:** IMPRES 2-batterijen met dit pictogram op het batterijlabel hoeven niet periodiek te worden gekalibreerd en gereviseerd wanneer ze in deze IMPRES 2-oplader worden geplaatst (met softwareversie V2.05 of nieuwer).

**Opmerking:** Zorg ervoor dat uw oplader altijd is bijgewerkt met de nieuwste firmware. Het applicatiepakket voor het herprogrammeren van MSI-opladers kan worden gedownload van Motorola Online (MOL) of de Motorola Solutions-website.

## Firmware bijwerken

**Opmerking:** Van toepassing op alle IMPRES-apparaten of -opladers van de 1e of 2e generatie; inclusief oplader-interface (CIU), batterijgegevenslezer (BDR), oplader voor één apparaat (SUC), dubbele oplader (DUC) en oplader voor meerdere apparaten (MUC).

Verwijder alle geplaatste batterijen uit het apparaat of de oplader voordat u een IMPRES-apparaat of -oplader upgradet naar een nieuwere versie.

1. Sluit het apparaat of de oplader via USB aan op uw computer. Het aangesloten apparaat of de aangesloten oplader wordt weergegeven in het hoofdvenster van de MSI Charger Reprogrammer.

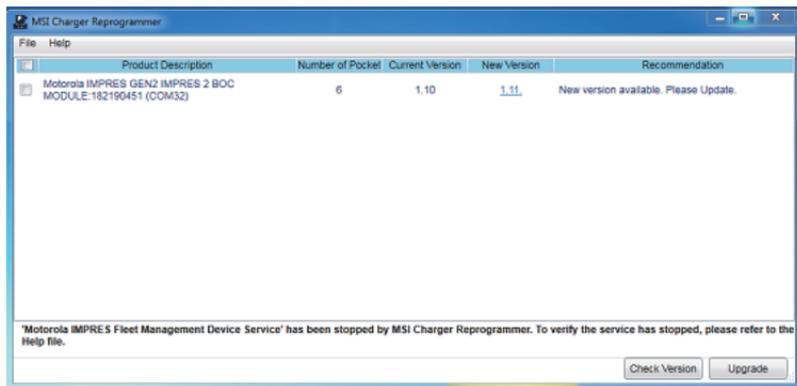

2. Klik op Check Version om de nieuwste beschikbare versie van MSI-server te vinden.

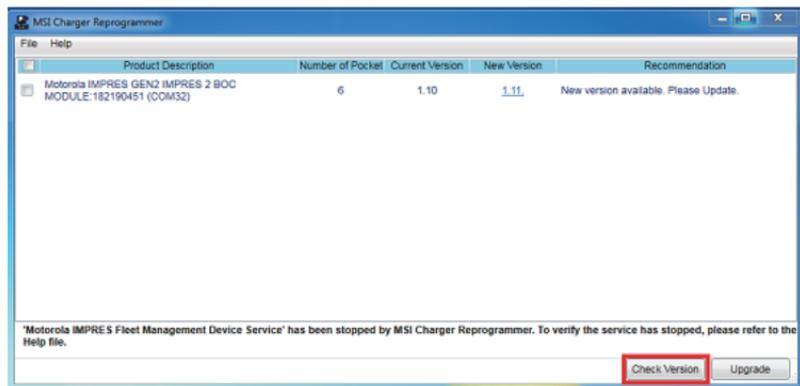

3. Selecteer het apparaat dat of de oplader die moet worden bijgewerkt.

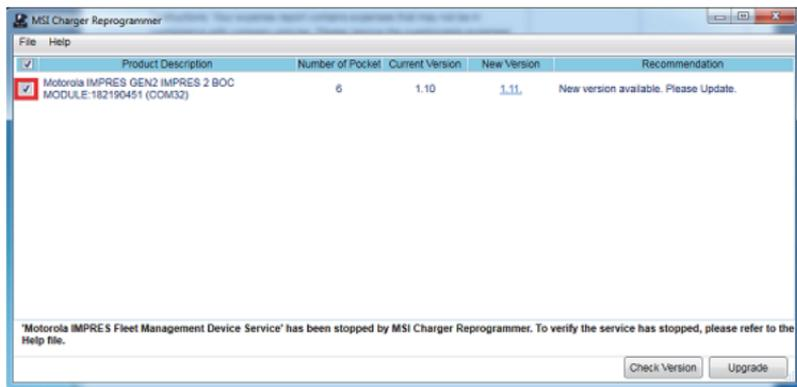

**Opmerking:** U kunt geen apparaten of opladers selecteren die al zijn bijgewerkt naar de nieuwste firmwareversie.

4. Klik op Upgrade uitvoeren om de firmware-upgrade te starten.

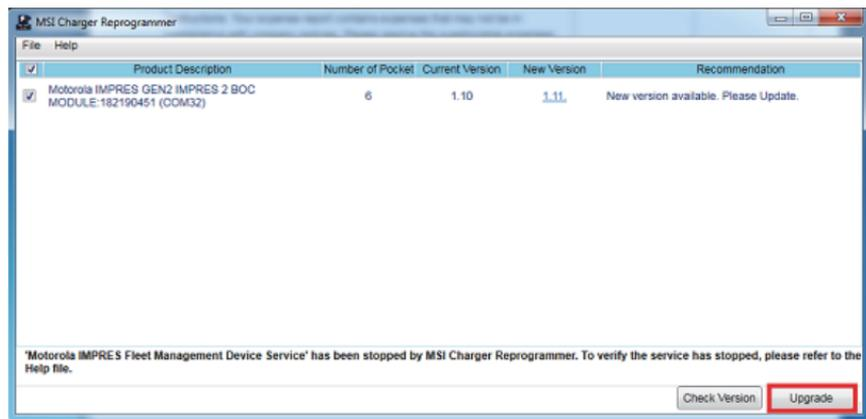

5. Klik op OK in het bevestigingsvenster wanneer u wordt gevraagd de upgrade te starten. Er wordt een venster weergegeven met de voortgang van de upgrade totdat deze is voltooid.

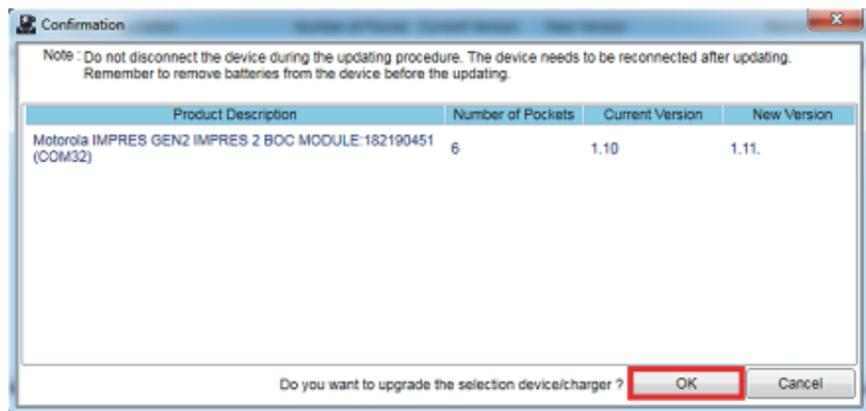

## 6. Sluit het venster zodra alle upgrades zijn voltooid.

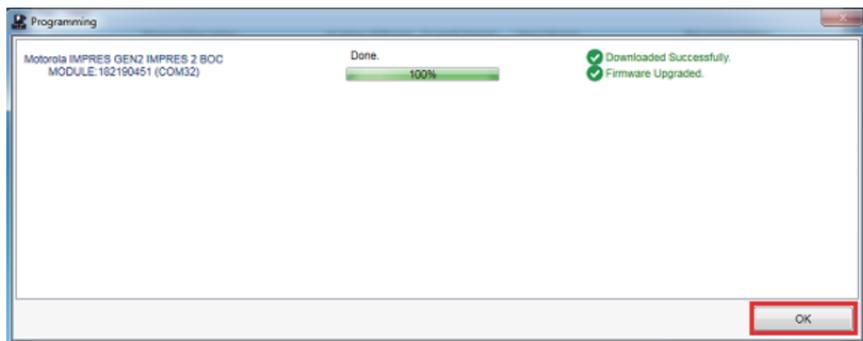

## Handmatig starten van de kalibratie/revisie



**LET OP:** Handmatige kalibratie of revisie zijn niet van toepassing op IMPRES- of IMPRES 2-batterijen met dit pictogram.

Hoewel kalibratie/revisie automatisch wordt uitgevoerd, kunnen er situaties voorkomen waarbij een handmatige start gewenst is. De oplader kan **afwisselend oranje of groen** branden voor de IMPRES 2- of IMPRES-batterij, omdat de kalibratie in de oplader is uitgeschakeld. Als die batterij binnen 30 minuten is verplaatst naar een oplader waarvoor de kalibratie is ingeschakeld, dan wordt de laatste oplaadtoestand hervat, waarmee wordt voorkomen dat de kalibratie/revisie automatisch start.

Als u de kalibratie/revisie handmatig wilt starten, verwijder dan de IMPRES 2- of IMPRES-batterij langer dan 2,5 minuut uit de oplader. Voer vervolgens deze stappen uit:

1. Plaats de batterij in het compartiment van de lader.
2. Verwijder binnen 2,5 minuut de batterij uit het opladercompartiment.
3. Plaats binnen 5 seconden de batterij weer in het compartiment van de lader.

De kalibratie/revisie start onmiddellijk, doorgaans begint dat met het ontladen van de batterij (**onafgebroken oranje**). Kalibratie/revisie is pas voltooid na volledig opladen (**onafgebroken groen**).

## Handmatig beëindigen kalibratie/revisie

Op elk gewenst moment tijdens het ontladen van de IMPRES 2- of IMPRES-batterij (onafgebroken oranje) kan de kalibratie/revisie worden beëindigd door onderstaande stappen te volgen:

1. Verwijder de batterij uit het compartiment van de lader.
2. Plaats binnen 5 seconden de batterij weer in het compartiment van de lader.

Batterij ontladen wordt onmiddellijk beëindigd en het normale opladen van de batterij begint. De LED geeft de oplaadstatus weer.

## Opladeroverzicht

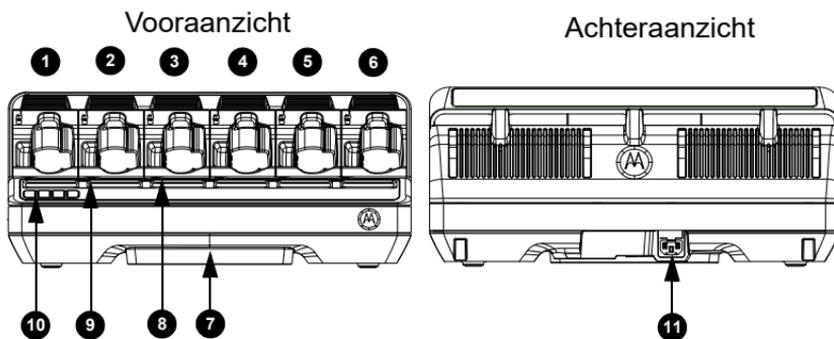

**Afbeelding 1:** Opladeroverzicht

**Tabel 5:** Overzicht en beschrijving van oplader

Nr.	Naam	Beschrijving
1–6	Opladercompartimenten	Elk compartiment herbergt een compatibele portofoon of losse batterij
7	Communicatiemodule	In bepaalde opladers laadt de communicatiemodule tevens USB-accessoires op: <ul style="list-style-type: none"> <li>• EU/UK PS000029A03</li> <li>• RK PS000029A08</li> </ul>



**Tabel 5: Overzicht en beschrijving van oplader (vervolg)**

Nr.	Naam	Beschrijving
8	LED-statusindicator compartiment	Oplaadstatuslampje (één per compartiment)
9	Display	Optionele display voor andere compartimenten dan Compartiment 1
10	Toetsenblok display	Display Compartiment 1 met menu-toetsenblok
11	AC-aansluiting	Maakt gebruik van stroomkabel specifiek voor het land of de regio

## **LED-indicatie einde levensduur IMPRES 2 of IMPRES**

De oplader kan een indicatie einde levensduur voor de IMPRES 2- of IMPRES-batterij geven (**afwisselend rood/groen**) na een succesvolle voltooiing van de kalibratie/revisie.

Bij batterijen die worden gebruikt, vermindert normale slijtage de beschikbare capaciteit. Na de succesvolle voltooiing van de kalibratie/revisie vergelijkt de oplader de capaciteit van de IMPRES 2- of IMPRES-batterij met de nominale capaciteit van de batterij. Wanneer de capaciteit een zeer lage waarde heeft, nadert de IMPRES 2- of IMPRES-batterij mogelijk het einde van haar levensduur. De IMPRES 2- of IMPRES-batterij blijft bruikbaar. In sommige gevallen kan het wenselijk zijn om de batterij aan iemand te geven die geen behoefte heeft aan een grote batterijcapaciteit voor één ploegendienst.

De APX NEXT XN-batterij heeft een functie om hoge temperaturen te detecteren in een IMPRES 2-oplader met softwareversie V2.05 of nieuwer. Wanneer deze functie is ingeschakeld, knippert het statuslampje afwisselend rood en groen na het opladen van een batterij die langdurig is blootgesteld aan extreem hoge temperaturen. De oplader geeft het volgende weer:

REPLACE BATTERY  
EXPOSED OVERTEMP

Het wordt aanbevolen om deze batterij buiten gebruik te stellen.

## Batterijen of portofoons met aangesloten batterijen opladen

Batterijen kunnen het best worden opgeladen bij kamertemperatuur. IMPRES 2-opladers voor meerdere apparaten kunnen een losse batterij of een batterij die is aangesloten op een portofoon opladen.

1. Plaats de oplader op een vlakke ondergrond.
2. Plaats de stroomkabel stevig in de AC-aansluiting van de oplader aan de achterzijde van de oplader.
3. Sluit de stroomkabel aan op een passend stopcontact.
4. Na succesvol inschakelen licht elk oplaadstatuslampje **Groen** op gedurende ongeveer één seconde en wordt `IMPRES 2 CHARGER` weergegeven. Controleer beide aansluitingen van de stroomkabel als de oplaadstatuslampjes niet knipperen en er geen bericht wordt weergegeven.
5. Plaats een portofoon met een aangesloten batterij of losse batterij in een beschikbaar compartiment.

**Opmerking:** Houd de portofoon aan de behuizing vast als u deze op de oplader aansluit of hiervan loskoppelt. Trek niet aan de antenne van een portofoon.

6. Wanneer de portofoon of losse batterij correct in het compartiment is geplaatst, wordt de oplaadstatus aangegeven door het bijbehorende oplaadstatuslampje. Het bijbehorende display geeft aanvullende informatie. Voor opladers met één display geeft het display alleen de oplaadstatus van compartiment 1 weer.
7. De batterij is gereed voor gebruik als de oplaadstatus **groen** is.
8. Schakel de portofoons alleen in als de communicatiemodule van de opladers is losgekoppeld van een pc. Als dat niet het geval is, moet u het apparaat of de portofoon uitschakelen.

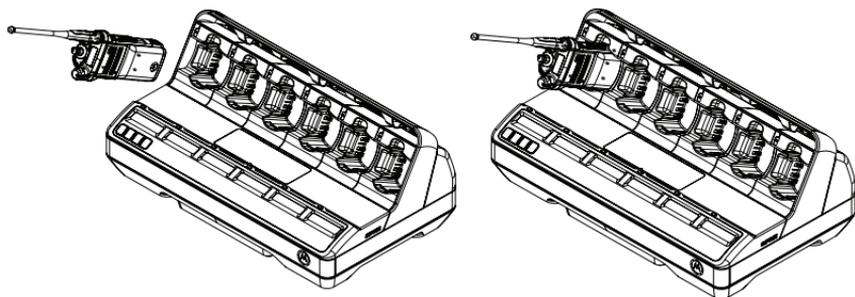

**Afbeelding 2:** Batterij bevestigd aan portofoon opladen

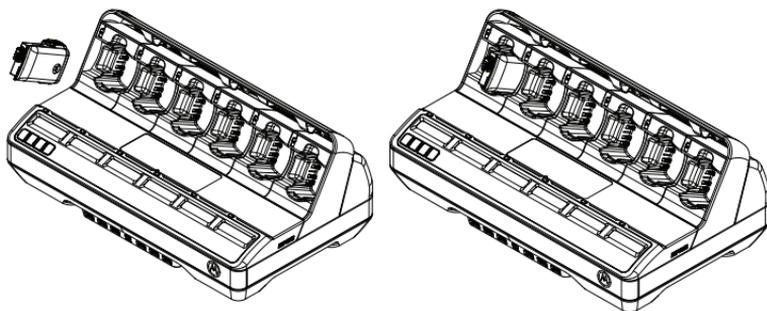

**Afbeelding 3:** Losse batterij opladen

## USB-accessoires opladen

Sommige communicatiemodules voor IMPRES 2-oplader voor meerdere apparaten bieden USB Type A-aansluitingen voor het opladen van USB-accessoires. Batterijen worden het beste opgeladen op kamertemperatuur.

1. Plaats de IMPRES 2 Adaptive-oplader op een vlakke ondergrond.
2. Plaats de stroomkabel stevig in het AC-contact aan de achterzijde van de lader.
3. Sluit de stroomkabel aan op een passend stopcontact.
4. Na succesvol inschakelen, licht elke compartiment-LED gedurende één seconde **groen** op en wordt **IMPRES 2 CHARGER** weergegeven. Controleer de aansluitingen van de stroomkabel als de status-LED's niet knipperen en er geen bericht wordt weergegeven.

- Een USB-accessoire kan een micro-AB-aansluiting hebben voor opladen. Gebruik een standaard USB-kabel van 1 meter of korter met een stekker van type A aan het ene uiteinde en een stekker compatibel met accessoires aan het andere uiteinde (doorgaans micro-B of micro-AB).
- Plaats de USB-kabel met type A-stekker goed uitgelijnd met de poort van type A op de communicatiemodule. Steek de stekker in de poort.
- Plaats de micro-B-stekker goed uitgelijnd met de micro-AB-aansluiting op het USB-accessoire. Steek de stekker in de aansluiting
- Wanneer de USB-aansluitingen goed vast zitten, wordt de oplaadstatus aangeduid door het USB-accessoire. Raadpleeg de gebruikershandleiding van het USB-accessoire voor meer informatie.

## Oplaadindicator

**Tabel 6:** Oplaadindicators van een IMPRES 2- of IMPRES-batterij - kalibratie niet nodig

Status	Compartment-display	LED-indicator
Oplader wordt ingeschakeld	IMPRES 2 CHARGER	Groen gedurende ongeveer 1 seconde 
Batterij gedetecteerd	IMPRES 2 BATTERY OF IMPRES BATTERY	Brandt rood 
Snel opladen	RAPID CHARGE XXXX@mAh yy%P+t1	Brandt rood 
Opgeladen tot 90% of meer	TRICKLE CHARGE xxxx@mAh yy%P+t1	Knippert groen 
Opgeladen tot 95% of meer	CHARGE COMPLETE xxxx@mAh yy%P+t1	Brandt groen 
Probleem	WAARSCHUWING: NOT CHARGEABLE REMOVE & REINSERT	Knippert rood 

**Tabel 6:** Oplaadindicators van een IMPRES 2- of IMPRES-batterij - kalibratie niet nodig (vervolg)

Status	Compartment-display	LED-indicator
Stand-by <ul style="list-style-type: none"> <li>• De batterij is in afwachting van snel opladen.</li> <li>• Batterij is te warm of te koud, of de spanning is te laag.</li> <li>• De oplader is te warm.</li> </ul>	WAARSCHUWING: HOT BATTERY WAITING TO CHARGE OF COLD BATTERY WAITING TO CHARGE OF VERY LOW BATTERY WAITING TO CHARGE OF HOT CHARGER WAITING TO CHARGE	Knippert oranje 

**Opmerking:**

- Het bericht `Hot Charger` is geïntroduceerd in softwareversie V1.05.
- Percentage-indicaties opladerstatus met betrekking tot potentiële capaciteit ten opzichte van nominale capaciteit is geïntroduceerd in softwareversie V1.11.01.

**Tabel 7:** Oplaadindicators voor de kalibratie van een IMPRES 2- of IMPRES-batterij - kalibratie ingeschakeld

Status	Compartment-display	LED-indicator
Oplader wordt ingeschakeld	IMPRES 2 CHARGER	Groen gedurende ongeveer 1 seconde 
Batterij gedetecteerd	IMPRES 2 BATTERY OF IMPRES BATTERY	Brandt oranje 
Batterij ontladen	CAL DISCHARGE xxxx0mAh yy%Pt1	Brandt oranje 
Snel opladen	CAL RAPID CHARGE xxxx0mAh yy%Pt1	Brandt rood 
Opgeladen tot 90% of meer	CAL TRICKLE CHARGE xxxx0mAh yy%Pt1	Knippert groen 

**Tabel 7:** Oplaadindicatoren voor de kalibratie van een IMPRES 2- of IMPRES-batterij - kalibratie ingeschakeld (vervolg)

Status	Compartment-display	LED-indicator
Opgeladen tot 95% of meer	CHARGE COMPLETE xxxxx0mAh yyyz%Pt.1	Batterijkalibratie gelukt: Brandt groen   Batterijkalibratie gelukt, maar batterij heeft mogelijk het einde van de levensduur bereikt (batterij is bruikbaar): Knippert rood/groen 
	REPLACE BATTERY EXPOSED OVERTEMP	Batterijkalibratie voltooid, maar batterij is blootgesteld aan cumulatief hoge temperaturen (aanbevolen om batterij uit flect te verwijderen): Knippert rood/groen OPMERKING: Alleen van toepassing op APX NEXT XN-batterij 
Probleem	WAARSCHUWING: NOT CHARGEABLE REMOVE & REINSERT	Knippert rood 
Stand-by • De batterij is in afwachting van snel opladen. • Batterij is te warm of te koud, of de spanning is te laag. • De oplader is te warm.	WAARSCHUWING: HOT BATTERY WAITING TO CAL OF COLD BATTERY WAITING TO CAL OF VERY LOW BATTERY WAITING TO CHARGE OF HOT CHARGER WAITING TO CAL	Knippert oranje 

**Tabel 8:** Oplaadindicators voor de kalibratie van een IMPRES 2- of IMPRES-batterij - kalibratie aanvankelijk uitgeschakeld, vervolgens ingeschakeld

Status	Opladerdisplay	LED-indicator
Oplader wordt ingeschakeld	IMPRES 2 CHARGER	Groen gedurende ongeveer 1 seconde 
Batterij gedetecteerd	IMPRES 2 BATTERY or IMPRES BATTERY	Batterij vereist kalibratie maar kalibratie is uitgeschakeld in de oplader: Afwisselend oranje/groen gedurende vier seconden. 
Aanvragen IMPRES-batterijkalibratie <ul style="list-style-type: none"> <li>• Kalibratie is uitgeschakeld in de oplader.</li> <li>• Batterij laadt op</li> </ul>	WAARSCHUWING: ENABLE BATTERY CALIBRATION?  <ul style="list-style-type: none"> <li>• Druk op OK om de kalibratie in te schakelen</li> <li>• Negeren voor normaal opladen (bericht verdwijnt na 1 minuut)</li> </ul>	Brandt rood 
Batterij ontladen <ul style="list-style-type: none"> <li>• OK geselecteerd</li> </ul>	CAL DISCHARGE xxxx@mAh yy%P t1	Brandt oranje 
Snel opladen	CAL RAPID CHARGE xxxx@mAh yy%P t1	Brandt rood 
Opgeladen tot 90% of meer	CAL TRICKLE CHRG xxxx@mAh yy%P t1	Knippert groen 

**Tabel 8:** Oplaadindicators voor de kalibratie van een IMPRES 2- of IMPRES-batterij - kalibratie aanvankelijk uitgeschakeld, vervolgens ingeschakeld (vervolg)

Status	Opladerdisplay	LED-indicator
Opgeladen tot 95% of meer	CHARGE COMPLETE xxxxx@mAh yyy%P t1	Batterijkalibratie gelukt: Brandt groen   Batterijkalibratie gelukt, maar batterij heeft mogelijk het einde van de levensduur bereikt (batterij is bruikbaar): Knippert rood/groen 
	REPLACE BATTERY EXPOSED OVERTEMP	Batterijkalibratie voltooid, maar batterij is blootgesteld aan cumulatief hoge temperaturen (aanbevolen om batterij uit fleet te verwijderen): Knippert rood/groen OPMERKING: Alleen van toepassing op APX NEXT XN-batterij 
Probleem	WAARSCHUWING: NOT CHARGEABLE REMOVE& REINSERT	Knippert rood 
Stand-by • De batterij is in afwachting van snel opladen. • Batterij is te warm of te koud, of de spanning is te laag. • De oplader is te warm.	WAARSCHUWING: HOT BATTERY WAITING TO CAL OF COLD BATTERY WAITING TO CAL OF VERY LOW BATTERY WAITING TO CHRG OF HOT CHARGER WAITING TO CAL	Knippert oranje 



**Tabel 9:** Oplaadindicatoren van een IMPRES 2- of IMPRES-batterij - kalibratie vereist, maar niet ingeschakeld

Status	Opladerdisplay	LED-indicator
Oplader wordt ingeschakeld	IMPRES 2 CHARGER	Groen gedurende ongeveer 1 seconde 
Batterij gedetecteerd	IMPRES 2 BATTERY of IMPRES BATTERY	Batterij vereist kalibratie maar kalibratie is uitgeschakeld in de oplader: Afwisselend oranje/ groen gedurende vier seconden. 
Aanvragen IMPRES-batterijkalibratie <ul style="list-style-type: none"> <li>• Kalibratie is uitgeschakeld in de oplader.</li> <li>• Batterij laadt op.</li> </ul>	WAARSCHUWING: ENABLE BATTERY CALIBRATION?  • Druk op OK om kalibratie in te schakelen. • Negeren voor normaal opladen (bericht verdwijnt na 1 minuut).	Brandt rood 
Snel opladen <ul style="list-style-type: none"> <li>• Aanvraag voor kalibratie is verlopen.</li> </ul>	RAPID CHARGE xxxxx@mAh yyy%P t1	Brandt rood 
Opgeladen tot 90% of meer	TRICKLE CHARGE xxxxx@mAh yyy%P t1	Knippert groen 
Opgeladen tot 95% of meer	CHARGE COMPLETE xxxxx@mAh yyy%P t1	Afwisselend oranje/ groen 
Probleem	WAARSCHUWING: HOT CHARGEABLE REMOVE& REINSERT	Knippert rood 
Stand-by <ul style="list-style-type: none"> <li>• De batterij is in afwachting van snel opladen.</li> <li>• Batterij is te warm of te koud, of de spanning is te laag.</li> <li>• De oplader is te warm.</li> </ul>	WAARSCHUWING: HOT BATTERY WAITING TO CHARGE OF COLD BATTERY WAITING TO CHARGE OF VERY LOW BATTERY WAITING TO CHARGE OF HOT CHARGER WAITING TO CHARGE	Knippert oranje 

**Tabel 10:** Oplaadindicatoren van een volledig opgeladen IMPRES 2- of IMPRES-batterij - kalibratie vereist, maar niet ingeschakeld

Status	Opladerdisplay	LED-indicator
Oplader wordt ingeschakeld	IMPRES 2 CHARGER	Groen gedurende ongeveer 1 seconde 
Batterij gedetecteerd	IMPRES 2 BATTERY of IMPRES BATTERY	De batterij moet worden gekalibreerd, maar is in de laatste 30 minuten volledig opgeladen, maar kalibratie is uitgeschakeld in de oplader: Afwisselend oranje/ groen 
Probleem	WAARSCHUWING: HOT CHARGEABLE REMOVE& REINSERT	Knippert rood 
Stand-by • De batterij is in afwachting van snel opladen. • Batterij is te warm of te koud, of de spanning is te laag. • De oplader is te warm.	WAARSCHUWING: HOT BATTERY WAITING TO CHARGE OF COLD BATTERY WAITING TO CHARGE OF VERY LOW BATTERY WAITING TO CHARGE OF HOT CHARGER WAITING TO CHARGE	Knippert oranje 

## Andere Motorola Solutions-batterijen

**Tabel 11:** Oplaadindicators voor andere Motorola Solutions-batterijen

Status	Opladerdisplay	LED-indicator
Oplader wordt ingeschakeld	IMPRES 2 CHARGER	Groen gedurende ongeveer 1 seconde 
Batterij gedetecteerd	MOTOROLA SOLUTIONS BATTERY	Brandt rood 
Snel opladen	RAPID CHARGE	Brandt rood 
Opgeladen tot 90% of meer	TRICKLE CHARGE	Knippert groen 
Opgeladen tot 95% of meer	CHARGE COMPLETE	Brandt groen 
Probleem	WAARSCHUWING: HOT CHARGEABLE REMOVE & REINSERT	Knippert rood 
Stand-by <ul style="list-style-type: none"> <li>• De batterij is in afwachting van snel opladen.</li> <li>• Batterij is te warm of te koud, of de spanning is te laag.</li> <li>• De oplader is te warm.</li> </ul>	WAARSCHUWING: HOT BATTERY WAITING TO CHARGE OF COLD BATTERY WAITING TO CHARGE OF VERY LOW BATTERY WAITING TO CHARGE OF HOT CHARGER WAITING TO CHARGE	Knippert oranje 

## Onbekende batterij

Sommige onbekende batterijen worden mogelijk niet gedetecteerd door de oplader. Onbekende batterijen geven hun oplaadparameters niet door op een manier die herkenbaar is voor de oplader. Als een onbekende batterij wordt gedetecteerd, geeft de oplader het opladen weer zoals samengevat in Tabel 12.

**Tabel 12:** Oplaadindicatoren voor onbekende batterijen

Status	Opladerdisplay	LED-indicator
Oplader wordt ingeschakeld	IMPRES 2 CHARGER	Groen gedurende ongeveer 1 seconde 
Batterij gedetecteerd	UNKNOWN BATTERY	Brandt rood 
Snel opladen	RAPID CHARGE	Brandt rood 
Bijna opgeladen • Batterijcapaciteit onbekend	TRICKLE CHARGE	Knippert groen 
Opgeladen • Batterijcapaciteit onbekend	CHARGE COMPLETE	Brandt groen 
Probleem	WAARSCHUWING: NOT CHARGEABLE REMOVE & REINSERT	Knippert rood 
Stand-by • De batterij is in afwachting van snel opladen. • Batterij is te warm of te koud, of de spanning is te laag. • De oplader is te warm.	WAARSCHUWING: HOT BATTERY WAITING TO CHARGE OF COLD BATTERY WAITING TO CHARGE OF VERY LOW BATTERY WAITING TO CHARGE OF HOT CHARGER WAITING TO CHARGE	Knippert oranje 

## Langdurige opslag van IMPRES 2- of IMPRES-batterij

Losse originele IMPRES 2- of IMPRES-batterijen van Motorola Solutions (lithium-ion of nikkel) kunnen met behulp van een IMPRES 2-oplader voor meerdere apparaten worden voorbereid voor langdurige opslag in een geschikte opslagruimte. Andere typen batterijen krijgen een batterijfout. Als de IMPRES 2-batterij is voorzien van een slaapstand, zet de oplader de batterij in de slaapstand na afloop van het opladen voor langdurige opslag.

Bereid alleen IMPRES 2- of IMPRES-batterijen voor op langdurige opslag. Verwijder de batterij uit de portofoon voordat u deze in de oplader plaatst.

Bewaar GEEN losse batterij in de oplader. Als de voorbereiding op langdurige opslag is voltooid, verwijder dan onmiddellijk de losse batterij uit de oplader.

Selectie van langdurige opslag (Long-Term Storage) heeft voorrang op kalibratie/revisie. Lithiumbatterijen die zijn voorbereid voor langdurige opslag voldoen mogelijk niet aan de voorschriften voor transport per luchtvracht.

**Tabel 13:** Indicators voor langdurige opslag van een IMPRES 2- of IMPRES-batterij - batterij moet worden gekalibreerd

Status	Opladerdisplay	LED-indicator
Oplader wordt ingeschakeld	IMPRES 2 CHARGER	Groen gedurende ongeveer 1 seconde 
Batterij gedetecteerd	IMPRES 2 BATTERY or IMPRES BATTERY	De batterij moet worden gekalibreerd: Afwisselend oranje/ groen gedurende vier seconden. 
Batterij ontladen	STORAGE DISCHARGE xxxx% Rated Cap	Brandt oranje 
Snel opladen	STORAGE CHARGE xxx% Rated Cap	Brandt rood 
Langdurige opslag voltooid	LONGTERM STORAGE xxx% Rated Cap	Afwisselend oranje/ groen 

**Tabel 13:** Indicators voor langdurige opslag van een IMPRES 2- of IMPRES-batterij - batterij moet worden gekalibreerd (vervolg)

Status	Opladerdisplay	LED-indicator
<p>Probleem</p> <ul style="list-style-type: none"> <li>Batterij maakt niet goed elektrisch contact met de oplader.</li> <li>De batterij is geen IMPRES 2- of IMPRES-batterij.</li> <li>Een onbekende toestand voorkomt dat de batterij wordt ontladen.</li> <li>Het opladen is voltooid voordat het langdurige opslagdoel is bereikt.</li> <li>Het opladercompartiment is een speciaal type.</li> </ul>	<p>WAARSCHUWING: NOT CHARGEABLE REMOVE&amp; REINSERT OF WRONG BATT TYPE CANNOT LT STORAGE OF CANNOT DISCHARGE FOR LT STORAGE OF STORE INCOMPLETE Lage capaciteit:yy% OF RADIO POCKET CANNOT LT STORAGE OF CHARGING POCKET CANNOT LT STORAGE</p>	<p>Knippert rood</p> 
<p>Stand-by</p> <ul style="list-style-type: none"> <li>De batterij is in afwachting van snel opladen.</li> <li>Batterij is te warm of te koud, of de spanning is te laag.</li> <li>De oplader is te warm.</li> </ul>	<p>WAARSCHUWING: HOT BATTERY WAITING TO CHRGE OF COLD BATTERY WAITING TO CHRGE OF VERY LOW BATTERY WAITING TO CHRGE OF HOT CHARGER WAITING TO CHRGE</p>	<p>Knippert oranje</p> 

**Opmerking:**

- De volgende berichten zijn geïntroduceerd in softwareversie V1.05:
  - Cannot Discharge, for LT Storage
  - Store Incomplete, Low Capacity:yy%
  - Hot Charger, Waiting to Chrge
- De volgende berichten zijn geïntroduceerd in softwareversie V1.11.01:
  - Wrong Batt Type, Cannot LT Store
  - Radio Pocket, Cannot LT Store
  - Charging Pocket, Cannot LT Store

**Tabel 14:** Indicators voor langdurige opslag van een IMPRES 2- of IMPRES-batterij - gekalibreerde batterij moet opladen tot selectie

Status	Opladerdisplay	LED-indicator
Oplader wordt ingeschakeld	IMPRES 2 CHARGER	Groen gedurende ongeveer 1 seconde 
Batterij gedetecteerd	IMPRES 2 BATTERY of IMPRES BATTERY	Brandt rood 
Snel opladen	STORAGE CHARGE xxx% Rated Cap	Brandt rood 
Langdurige opslag voltooid	LONGTERM STORAGE xxx% Rated Cap	Brandt groen 
<p>Probleem</p> <ul style="list-style-type: none"> <li>Batterij maakt niet goed elektrisch contact met de oplader.</li> <li>De batterij is geen IMPRES 2- of IMPRES-batterij.</li> <li>Een onbekende toestand voorkomt dat de batterij wordt ontladen.</li> <li>Het opladen is voltooid voordat het langdurige opslagdoel is bereikt.</li> <li>Het opladercompartiment is een speciaal type.</li> </ul>	<p>WAARSCHUWING: NOT CHARGEABLE REMOVE&amp; REINSERT OF WRONG BATT TYPE CANNOT LT STORAGE OF CANNOT DISCHARGE FOR LT STORAGE OF STORE INCOMPLETE Lage capaciteit:yy% OF RADIO POCKET CANNOT LT STORAGE OF CHARGING POCKET CANNOT LT STORAGE</p>	Knippert rood 
<p>Stand-by</p> <ul style="list-style-type: none"> <li>De batterij is in afwachting van snel opladen.</li> <li>Batterij is te warm of te koud, of de spanning is te laag.</li> <li>De oplader is te warm.</li> </ul>	<p>WAARSCHUWING: HOT BATTERY WAITING TO CHARGE OF COLD BATTERY WAITING TO CHARGE OF VERY LOW BATTERY WAITING TO CHARGE OF HOT CHARGER WAITING TO CHARGE</p>	Knippert oranje 

**Tabel 15:** Indicators voor langdurige opslag van een IMPRES 2- of IMPRES-batterij - gekalibreerde batterij moet ontladen tot selectie

Status	Opladerdisplay	LED-indicator
Oplader wordt ingeschakeld	IMPRES 2 CHARGER	Groen gedurende ongeveer 1 seconde 
Batterij gedetecteerd	IMPRES 2 BATTERY of IMPRES BATTERY	Brandt oranje 
Batterij ontladen	STORAGE DISCHARGE xxx% Rated Cap	Brandt oranje 
Langdurige opslag voltooid	LONGTERM STORAGE xxx% Rated Cap	Brandt groen 
<p>Probleem</p> <ul style="list-style-type: none"> <li>Batterij maakt niet goed elektrisch contact met de oplader.</li> <li>De batterij is geen IMPRES 2- of IMPRES-batterij.</li> <li>Een onbekende toestand voorkomt dat de batterij wordt ontladen.</li> <li>Het opladen is voltooid voordat het langdurige opslagdoel is bereikt.</li> <li>Het opladercompartiment is een speciaal type.</li> </ul>	<p>WAARSCHUWING: HOT CHARGEABLE REMOVE&amp; REINSERT OF WRONG BATT TYPE CANNOT LT STORAGE OF CANNOT DISCHARGE FOR LT STORAGE OF STORE INCOMPLETE Lage capaciteit:yy% OF RADIO POCKET CANNOT LT STORAGE OF CHARGING POCKET CANNOT LT STORAGE</p>	<p>Knippert rood </p>
<p>Stand-by</p> <ul style="list-style-type: none"> <li>De batterij is in afwachting van snel opladen.</li> <li>Batterij is te warm of te koud, of de spanning is te laag.</li> <li>De oplader is te warm.</li> </ul>	<p>WAARSCHUWING: HOT BATTERY WAITING TO CHARGE OF COLD BATTERY WAITING TO CHARGE OF VERY LOW BATTERY WAITING TO CHARGE OF HOT CHARGER WAITING TO CHARGE</p>	<p>Knippert oranje </p>



## Vorbereiden van een lithium-ion batterij voor transport

Losse IMPRES 2-, IMPRES-, of andere originele lithium-ion batterijen van Motorola Solutions kunnen met behulp van een IMPRES 2-oplader voor meerdere apparaten worden voorbereid voor verzending per luchtvracht. Andere typen batterijen krijgen een batterijfout. Als de lithium-ion IMPRES 2-batterij is voorzien van een slaapstand, zet de oplader de batterij in de slaapstand na afloop van het opladen voor lithiumverzending (Ship Lithium).

Bereid alleen losse lithium-ion batterijen van Motorola Solutions voor op verzending. Verwijder de batterij uit de portofoon voordat u deze in de oplader plaatst.

Bewaar GEEN losse batterij in de oplader. Als de voorbereiding op Ship Lithium is voltooid, verwijder dan onmiddellijk de losse batterij uit de oplader.

Selectie van Ship Lithium heeft voorrang op kalibratie/revisie.

### IMPRES 2- of IMPRES-batterij

**Tabel 16:** Statusindicatoren voor het voorbereiden van een lithium-ion batterij op verzending - IMPRES 2- of IMPRES-batterij moet worden gekalibreerd

Status	Opladerdisplay	LED-indicator
Oplader wordt ingeschakeld	IMPRES 2 CHARGER	Groen gedurende ongeveer 1 seconde 
Batterij gedetecteerd	IMPRES 2 BATTERY of IMPRES BATTERY	De batterij moet worden gekalibreerd: Afwisselend oranje/ groen gedurende vier seconden. 
Batterij ontladen	SHIP LI DISCHARGE xxx% Rated Cap	Brandt oranje 
Snel opladen	SHIP LI CHARGE xxx% Rated Cap	Brandt rood 
Lithiumverzending voltooid	LI READY TO SHIP xxx% Rated Cap	Afwisselend oranje/ groen 

**Tabel 16:** Statusindicators voor het voorbereiden van een lithium-ion batterij op verzending - IMPRES 2- of IMPRES-batterij moet worden gekalibreerd (vervolg)

Status	Opladerdisplay	LED-indicator
<p>Probleem</p> <ul style="list-style-type: none"> <li>Batterij maakt niet goed elektrisch contact met de oplader.</li> <li>Batterij is onbekend of is een nikkelbatterij.</li> <li>Een onbekende toestand voorkomt dat de batterij wordt ontladen.</li> <li>Het opladen is voltooid voordat het Ship Lithium-doel is bereikt.</li> <li>Het opladercompartiment is een speciaal type.</li> </ul>	<p>WAARSCHUWING:            NOT CHARGEABLE            REMOVE&amp; REINSERT            OF            WRONG BATT TYPE            CANNOT SHIP LI            OF            CANNOT DISCHARGE            FOR LI SHIPMENT            OF            SHIP INCOMPLETE            Lage            capaciteit:yy%            OF            RADIO POCKET            CANNOT SHIP LI            OF            CHARGING POCKET            CANNOT SHIP LI</p>	<p>Knippert rood</p> 
<p>Stand-by</p> <ul style="list-style-type: none"> <li>De batterij is in afwachting van snel opladen.</li> <li>Batterij is te warm of te koud, of de spanning is te laag.</li> <li>De oplader is te warm.</li> </ul>	<p>WAARSCHUWING:            HOT BATTERY            WAITING TO CHRGE            OF            COLD BATTERY            WAITING TO CHRGE            OF            VERY LOW BATTERY            WAITING TO CHRGE            OF            HOT CHARGER            WAITING TO CHRGE</p>	<p>Knippert oranje</p> 

**Opmerking:**

- De volgende berichten zijn geïntroduceerd in softwareversie V1.05:
  - Ship LI Discharge, xxx% Rated Capacity
  - Ship LI Charge, xxx% Rated Capacity
  - LI Ready to Ship, xx% Rated Capacity
  - Cannot Discharge, for LI Shipment
  - Ship Incomplete, Low Capacity:yy%
- De volgende berichten zijn geïntroduceerd in softwareversie V1.11.01:
  - Wrong Batt Type, Cannot Ship LI
  - Radio Pocket, Cannot Ship LI
  - Charging Pocket, Cannot Ship LI

**Tabel 17:** Statusindicatoren voor het voorbereiden van een lithium-ion batterij op verzending - IMPRES 2- of IMPRES-batterij gekalibreerd, moet opladen

Status	Opladerdisplay	LED-indicator
Oplader wordt ingeschakeld	IMPRES 2 CHARGER	Groen gedurende ongeveer 1 seconde 
Batterij gedetecteerd	IMPRES 2 BATTERY of IMPRES BATTERY	Brandt rood 
Snel opladen	SHIP LI CHARGE xxx% Rated Cap	Brandt rood 
Lithiumverzending voltooid	LI READY TO SHIP xxx% Rated Cap	Brandt groen 
<p>Probleem</p> <ul style="list-style-type: none"> <li>Batterij maakt niet goed elektrisch contact met de oplader.</li> <li>Batterij is onbekend of is een nikkelbatterij.</li> <li>Een onbekende toestand voorkomt dat de batterij wordt ontladen.</li> <li>Het opladen is voltooid voordat het Ship Lithium-doel is bereikt.</li> <li>Het opladercompartiment is een speciaal type.</li> </ul>	<p>WAARSCHUWING: NOT CHARGEABLE REMOVE&amp; REINSERT OF WRONG BATT TYPE CANNOT SHIP LI OF CANNOT DISCHARGE FOR LI SHIPMENT OF SHIP INCOMPLETE Lage capaciteit:yy% OF RADIO POCKET CANNOT SHIP LI OF CHARGING POCKET CANNOT SHIP LI</p>	Knippert rood 
<p>Stand-by</p> <ul style="list-style-type: none"> <li>De batterij is in afwachting van snel opladen.</li> <li>Batterij is te warm of te koud, of de spanning is te laag.</li> <li>De oplader is te warm.</li> </ul>	<p>WAARSCHUWING: HOT BATTERY WAITING TO CHARGE OF COLD BATTERY WAITING TO CHARGE OF VERY LOW BATTERY WAITING TO CHARGE OF HOT CHARGER WAITING TO CHARGE</p>	Knippert oranje 

**Tabel 18:** Statusindicatoren voor het voorbereiden van een lithium-ion batterij op verzending - IMPRES 2- of IMPRES-batterij gekalibreerd, moet ontladen

Status	Opladerdisplay	LED-indicator
Oplader wordt ingeschakeld	IMPRES 2 CHARGER	Groen gedurende ongeveer 1 seconde 
Batterij gedetecteerd	IMPRES 2 BATTERY of IMPRES BATTERY	Brandt oranje 
Batterij ontladen	SHIP LI DISCHARGE xxx% Rated Cap	Brandt oranje 
Lithiumverzending voltooid	LI READY TO SHIP xxx% Rated Cap	Brandt groen 
<p>Probleem</p> <ul style="list-style-type: none"> <li>Batterij maakt niet goed elektrisch contact met de oplader.</li> <li>Batterij is onbekend of is een nikkelbatterij.</li> <li>Een onbekende toestand voorkomt dat de batterij wordt ontladen.</li> <li>Het opladen is voltooid voordat het Ship Lithium-doel is bereikt.</li> <li>Het opladercompartiment is een speciaal type.</li> </ul>	<p>WAARSCHUWING: NOT CHARGEABLE REMOVE&amp; REINSERT OF WRONG BATT TYPE CANNOT SHIP LI OF CANNOT DISCHARGE FOR LI SHIPMENT OF SHIP INCOMPLETE Lage capaciteit:yy% OF RADIO POCKET CANNOT SHIP LI OF CHARGING POCKET CANNOT SHIP LI</p>	<p>Knippert rood </p>
<p>Stand-by</p> <ul style="list-style-type: none"> <li>De batterij is in afwachting van snel opladen.</li> <li>Batterij is te warm of te koud, of de spanning is te laag.</li> <li>De oplader is te warm.</li> </ul>	<p>WAARSCHUWING: HOT BATTERY WAITING TO CHARGE OF COLD BATTERY WAITING TO CHARGE OF VERY LOW BATTERY WAITING TO CHARGE OF HOT CHARGER WAITING TO CHARGE</p>	<p>Knippert oranje </p>

## Andere Motorola Solutions-batterijen

**Tabel 19:** Statusindicatoren voor het voorbereiden van een lithium-ion batterij voor verzending - andere batterij van Motorola Solutions

Status	Opladerdisplay	LED-indicator
Oplader wordt ingeschakeld	IMPRES 2 CHARGER	Groen gedurende ongeveer 1 seconde 
Batterij gedetecteerd	MOTOROLA SOLUTIONS BATTERY	Brandt oranje 
Batterij ontladen	SHIP LI DISCHARGE xxx% Rated Cap	Brandt oranje 
Snel opladen	SHIP LI CHARGE xxx% Rated Cap	Brandt rood 
Lithiumverzending voltooid	LI READY TO SHIP xxx% Rated Cap	Brandt groen 
<b>Probleem</b> <ul style="list-style-type: none"> <li>Batterij maakt niet goed elektrisch contact met de oplader.</li> <li>Batterij is onbekend of is een nikkelbatterij.</li> <li>Een onbekende toestand voorkomt dat de batterij wordt ontladen.</li> <li>Het opladen is voltooid voordat het Ship Lithiumdoel is bereikt.</li> <li>Het opladercompartiment is een speciaal type.</li> </ul>	<b>WAARSCHUWING:</b> NOT CHARGEABLE REMOVE& REINSERT OF WRONG BATT TYPE CANNOT SHIP LI OF CANNOT DISCHARGE FOR LI SHIPMENT OF SHIP INCOMPLETE Lage capaciteit:yy% OF RADIO POCKET CANNOT SHIP LI OF CHARGING POCKET CANNOT SHIP LI	Knippert rood 
<b>Stand-by</b> <ul style="list-style-type: none"> <li>De batterij is in afwachting van snel opladen.</li> <li>Batterij is te warm of te koud, of de spanning is te laag.</li> <li>De oplader is te warm.</li> </ul>	<b>WAARSCHUWING:</b> HOT BATTERY WAITING TO CHARGE OF COLD BATTERY WAITING TO CHARGE OF VERY LOW BATTERY WAITING TO CHARGE OF HOT CHARGER WAITING TO CHARGE	Knippert oranje 

## Setup Menu oplader



Maak alle ladercompartimenten leeg voordat u naar de instellingen voor de oplader gaat.

Het toetsenblok van de oplader bevindt zich onder het display van Compartment 1.

Om het instellingenmenu van de oplader te openen, houdt u de toets met de pijl naar links en met de pijl naar rechts langer ingedrukt dan de geselecteerde invoertijd (standaard 3 seconden).



Pijl naar links

Pijl naar rechts

**Afbeelding 4:** Weergaveknoppen voor openen instellingenmenu

## Hoofdmenu

Na het openen van het instellingenmenu wordt het volgende bericht weergegeven:

Press OK to entr  
SETUP MENU

Indrukken van de toets OK zorgt voor weergave van het beschikbare Setup Menu voor de oplader.

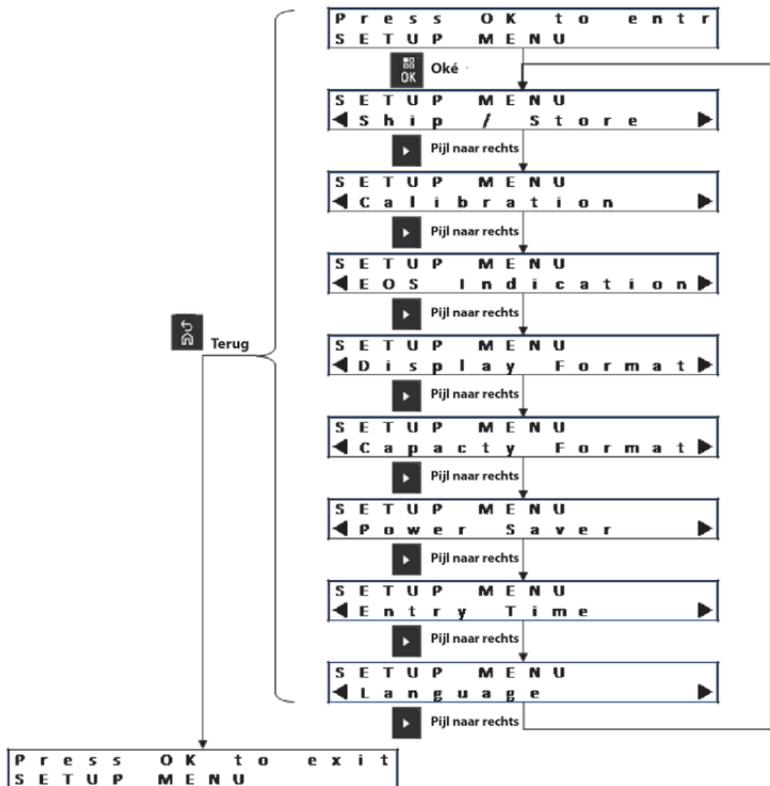

Afbeelding 5: Setup Menu oplader

## Selectie Setup Menu oplader

In elke selectie in het Setup Menu:

- Om door de menuselecties te navigeren, drukt u op de pijl naar rechts.
- Om door de menuselecties te navigeren in omgekeerde volgorde, drukt u op de pijl naar links.
- Om het geselecteerde menu te openen of de gewenste optie te selecteren, drukt u op OK.

**Opmerking:** Het vinkje geeft de geselecteerde optie aan. Druk op OK om het volgende compartiment op het display van Compartiment 1 weer te geven. Dit is geïntroduceerd in versie V1.11.01.

- Om het geselecteerde menu te verlaten, drukt u op Back en drukt u vervolgens op OK ter bevestiging van het afsluiten.

Als er gedurende 10 minuten geen toets van het toetsenblok wordt ingedrukt, verlaat de oplader het Setup Menu en keert terug naar de normale berichtweergave.

Geselecteerde opladerinstellingen worden opgeslagen in niet-vluchtig geheugen. Selecties worden niet beïnvloed door de laadcyclus.

## Ship/Storage Menu

Er zijn vier opties voor verzenden/opslag:

- Uitgeschakeld
- Ship Lithium-Ion
- Langdurige opslag
- Langdurige opslag bij 75% van de nominale capaciteit

Ship Lithium-Ion, langdurige opslag en langdurige opslag bij 75% van de nominale capaciteit hebben voorrang op de instelling voor kalibratie.

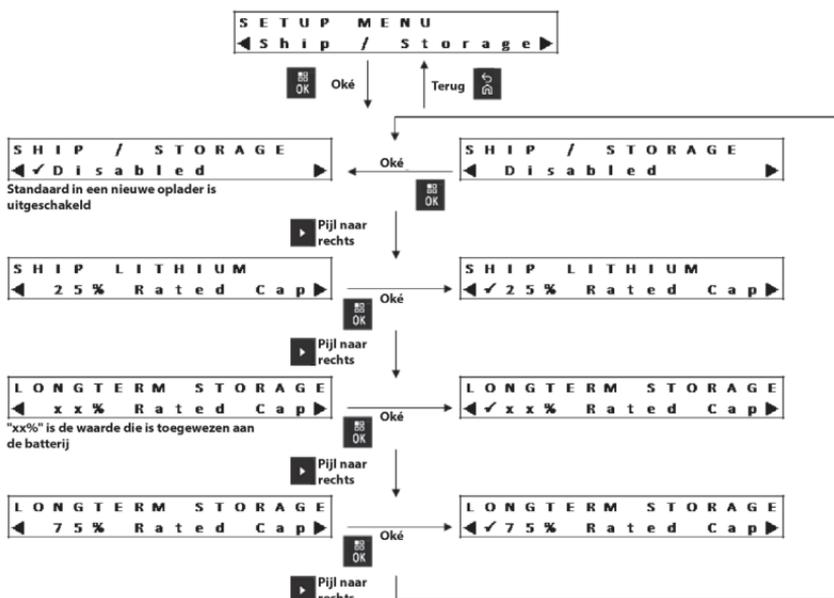

Afbeelding 6: Het menu Ship/Storage



## Ship Lithium

Ship Lithium (Lithium verzenden) stelt de oplaadstatus van een Motorola Solutions lithium-ion batterij in op een lage waarde die is toegestaan voor bulkklading: ongeveer 25% van de nominale capaciteit (Rated Capacity).

Sommige Motorola Solutions-batterijen kunnen volledig ontladen zijn voordat ze worden opgeladen tot de Ship Lithium-limiet. Dat is het geval bij IMPRES 2- of IMPRES-batterijen die nog niet eerder gekalibreerd zijn of opnieuw gekalibreerd moeten worden en bij andere originele Motorola Solutions-batterijen dan de IMPRES 2 of IMPRES.

Ship Lithium geldt alleen voor originele Motorola Solutions lithium-ion batterijen (IMPRES 2, IMPRES, of andere Motorola Solutions lithium-ion batterijen). Andere batterijen (zoals onbekende batterijen of nikkel- of clamshell-batterijen van Motorola Solutions) krijgen een foutmelding.

## Long-Term Storage

De optie Long-Term Storage (Langdurige opslag) stelt de IMPRES 2- of IMPRES-batterij in op een oplaadstatus die geschikt is voor het opslaan van de batterij voor een langere periode. Over het algemeen is de voorkeursoplaadstatus voor opslag beduidend lager dan volledige oplading. De xx%-selectie is een waarde die in de IMPRES 2- of IMPRES-batterij is geprogrammeerd of standaard 50% van de nominale capaciteit (Rated Capacity) bedraagt. Langdurige opslag op 75% van de nominale capaciteit is beschikbaar voor scenario's waarbij de opgeslagen batterij met een hogere oplaadstatus opgeslagen moet worden, zoals bij een kortere tijd voor volledig opladen als de batterij snel gebruikt moet kunnen worden.

Sommige IMPRES 2- of IMPRES-batterijen kunnen volledig ontladen zijn voordat ze worden opgeladen voor langdurige opslag. Voorbeelden van dergelijke batterijen zijn IMPRES 2- of IMPRES-batterijen die nooit zijn gekalibreerd of opnieuw gekalibreerd moeten worden.

Langdurige opslag geldt alleen voor IMPRES 2- of IMPRES-batterijen. Andere batterijen (zoals onbekende batterijen of niet-IMPRES- of clamshell-batterijen van Motorola Solutions) krijgen een foutmelding.

## IMPRES 2-batterijen met slaapstand

Sommige IMPRES 2-batterijen zijn uitgerust met een slaapstand. Deze slaapstand wordt gebruikt om de tijd tot de volgende oplaadbeurt te verlengen. Na voltooiing van Ship Lithium of Long-Term Storage zet de oplader deze batterijen in de slaapstand.

Een slapende IMPRES 2-batterij wordt 'gewekt' door deze in een oplader te plaatsen. Als de batterij is voorbereid voor lithiumverzending, wordt de batterij weer in de slaapstand gezet door deze in een oplader te plaatsen die is ingesteld op Ship Lithium. Als de batterij is voorbereid voor langdurige opslag, wordt de batterij weer in de slaapstand gezet door deze in een oplader te plaatsen die is ingesteld op Long-Term Storage.

### Menu Calibration

De selecties bij de kalibratie-instellingen activeren of deactiveren de ontladfase van de kalibratie/revisie. De ontladfase gaat vooraf aan de volledige lading die vereist is voor een geslaagde kalibratie/revisie. Deze functie is handig wanneer de oplader wordt gebruikt op een locatie waar de batterij zo snel mogelijk paraat moet zijn. In dergelijke situaties kan het lastig zijn om te wachten tot de batterij volledig ontladen is.

Als een IMPRES 2- of IMPRES-batterij moet worden gekalibreerd en al is ontladen toen deze in de oplader is geplaatst, maakt de oplader van de gelegenheid gebruik om het geheel opladen als batterijkalibratie te gebruiken.

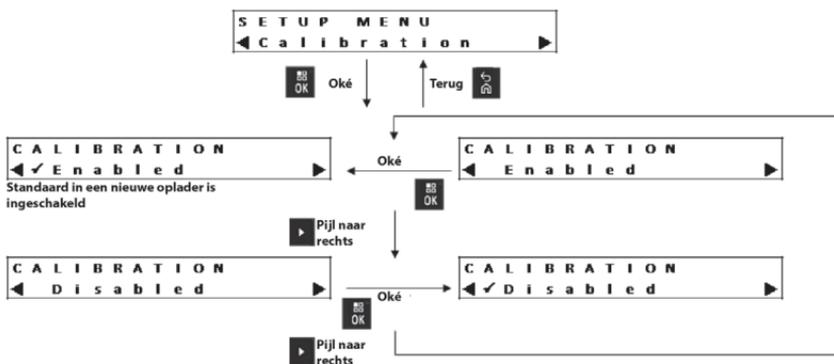

Afbeelding 7: Menu Calibration

## Menu LED-indicatie einde levensduur

Ook als de IMPRES 2- of IMPRES-batterij het einde van haar levensduur nadert, kan de batterijcapaciteit nog ruim voldoende zijn voor lichter gebruik. Het kan dus wenselijk zijn de LED-indicatie voor einde van levensduur (**afwisselend rood/groen**) uit te schakelen.

Als u deze indicatie uitschakelt voor een APX NEXT XN-batterij, dan wordt ook de indicatie voor cumulatieve blootstelling aan hoge temperaturen uitgeschakeld.

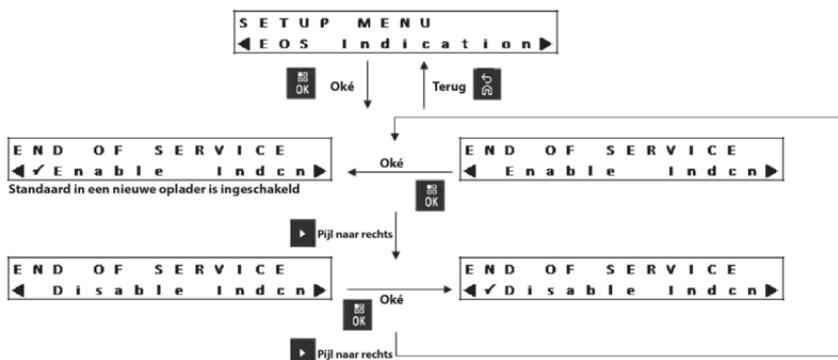

**Afbeelding 8:** Menu LED-indicatie einde levensduur

## Menu Display Format

Er zijn vier opties voor het weergaveformaat:

- Normal stand (oplader staat op een bureau).
- Gekantelde stand (oplader hangt aan de muur).
- Alleen waarschuwingsberichten. Andere berichten worden niet weergegeven. Dit geldt voor normale en gekantelde stand. Waarschuwingsberichten worden geïdentificeerd in Tabel 6 via Tabel 12.
- Display is uitgeschakeld tijdens normale werking. Het display is altijd ingeschakeld in de instellings- en analysemodus.

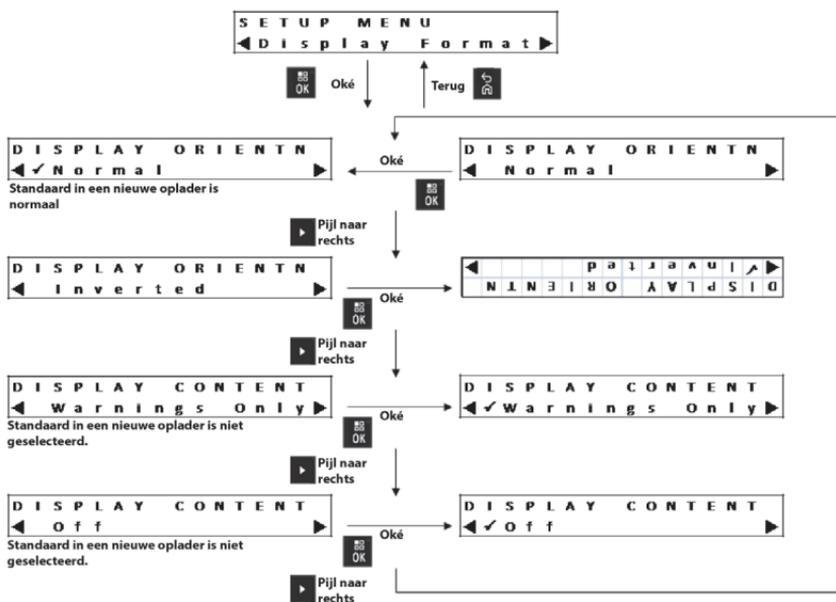

Afbeelding 9: Menu Display Format



**Tabel 20: Weergaveopties batterijcapaciteit**

Weergave	Beschrijving
xxx0mAh	Huidige oplaadstatus (State of Charge of SoC) in milliampère/uur.
yyy%	Aanwezige lading ten opzichte van de potentiële capaciteit (Potential Capacity) of nominale capaciteit (Rated Capacity) in procenten. Wanneer er wordt verwezen naar potentiële capaciteit, is de maximumwaarde 100%. Wanneer er wordt verwezen naar nominale capaciteit, kan de maximale waarde hoger zijn dan 100%, met name bij een nieuwe batterij.
%BAR	Het equivalent van yyy% weergegeven in een balk met acht segmenten.

## Menu Power Saver

Om te voldoen aan de overheidseisen voor stand-bystroom kan de oplader alle compartimenten, behalve Compartiment 1, uitschakelen als er gedurende een bepaalde periode geen activiteit in deze compartimenten plaatsvindt. Voorbeelden van activiteiten zijn onder meer de volgende:

- Portofoon of batterij opladen.
- Batterijkalibratie/revisie.
- Voorbereiding van originele lithium-ion batterijen van Motorola Solutions voor verzending.
- Voorbereiding van IMPRES 2- of IMPRES-batterij op langdurige opslag.
- Instellingen- of analysemodus van de oplader.
- Herprogrammering van de oplader.
- Communicatie met het IMPRES-batterij-fleetmanagementsysteem.
- Iedere knipperende LED-indicatie.

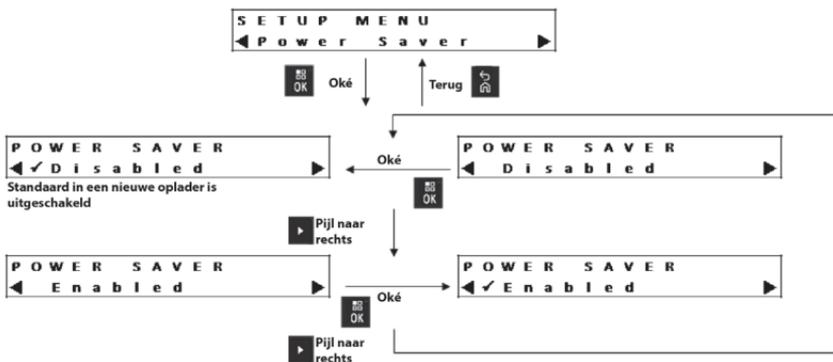

**Afbeelding 11: Menu Power Saver**

Compartiment 1 blijft ingeschakeld, maar kan in slaap zijn. Voor het inschakelen van de andere compartimenten drukt u op een willekeurige toets op het toetsenblok. Totdat de andere compartimenten zijn ingeschakeld, kunnen ze niet reageren op het plaatsen of verwijderen van een portofoon of batterrij.

## Menu Entry Time

De Invoertijd (Entry Time) is de tijd waarin de knop ingedrukt blijft die nodig is om de instellingen- of analysemodus van de oplader te openen.

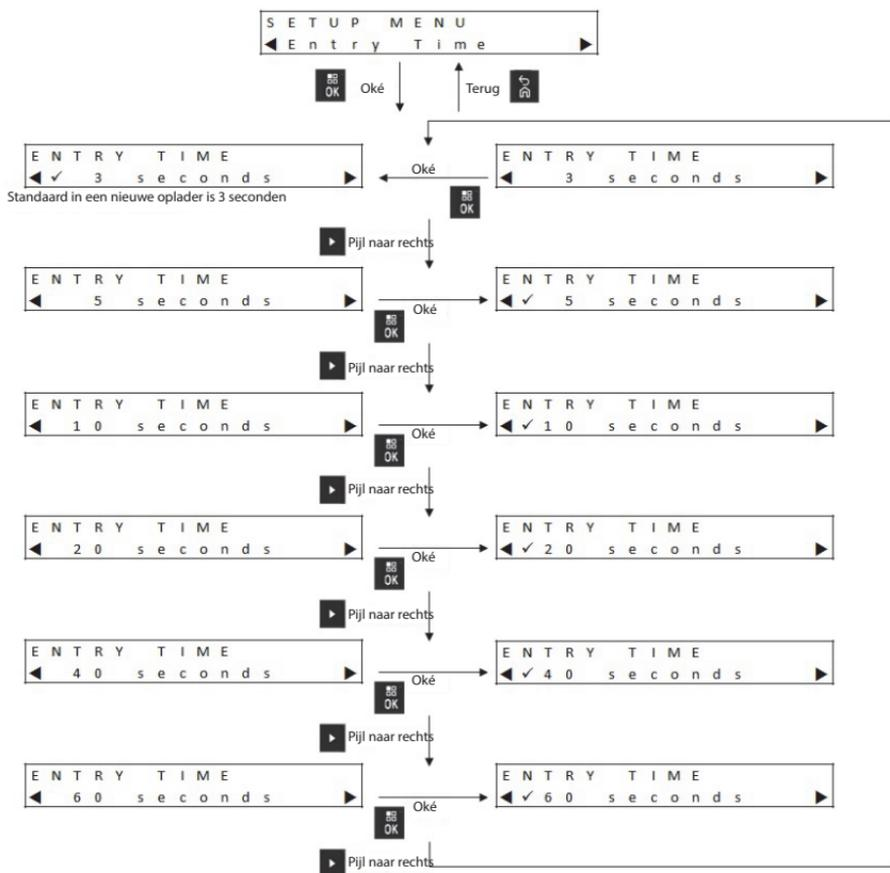

Afbeelding 12: Het menu Entry Time

## Menu Language

Op dit moment heeft de oplader ondersteuning voor de taal: Noord-Amerikaans Engels.

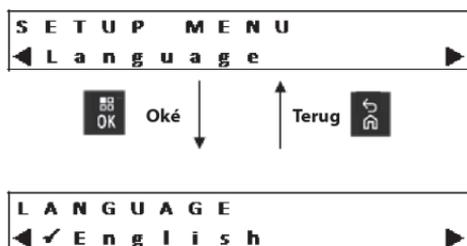

Afbeelding 13: Menu Language

## Analysemodus

Het toetsenblok van de oplader bevindt zich onder het display van Compartment 1.

Om de analysemodus te openen, houdt u de OK-knop langer dan de geselecteerde invoertijd (standaard 3 seconden) ingedrukt.



Afbeelding 14: Menuknoppen voor openen van analysemodus

Na het openen van de analysemodus wordt het volgende bericht weergegeven:

```
Press OK to entr  
ANALYZER MODE
```

Indrukken van de toets OK zorgt voor weergave van de beschikbare informatie over de batterij.



## Versie V1.0 van de analysemodus

In softwareversie 1.0 is de analysemodus beperkt tot Compartment 1. Analyse-informatie over Compartment 1 en de inhoud ervan staan aangegeven op het display van Compartment 1. Als er gedurende 10 minuten geen toets van het toetsenblok wordt ingedrukt, verlaat de oplader de analysemodus en keert deze terug naar de normale berichtweergave.

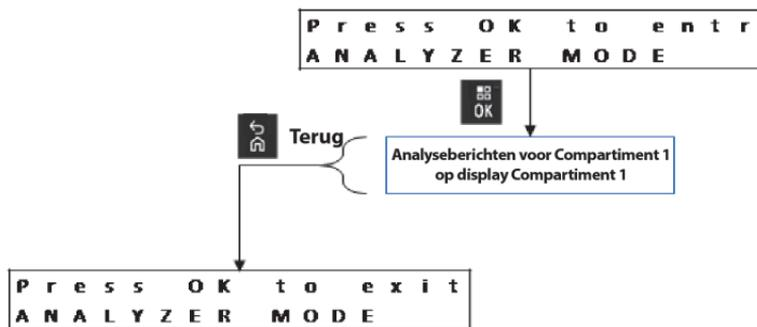

Afbeelding 15: Versie V1.0 van het analysemodusmenu

## Versie V1.05 van de analysemodus

De analysemodus is verbeterd met de introductie van opladersoftwareversie V1.05. Voor opladers met een display op ieder compartiment wordt analyse-informatie weergegeven op het display naast het bijbehorende compartiment. Wanneer u door de analyse-informatie over Compartiment 1 bladert, bladeren andere displays door analyse-informatie die beschikbaar is voor het aangrenzende compartiment.

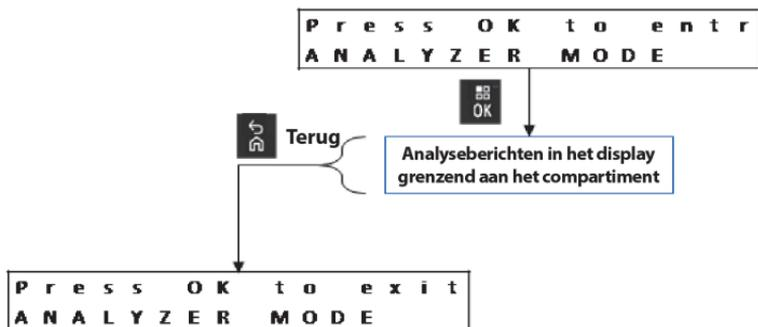

**Afbeelding 16:** Versie V1.05 van het analysemodusmenu

## Versie V1.11.01 van de analysemodus

De analysemodus is opnieuw verbeterd met de introductie van opladersoftwareversie V1.11.01. Bij opladers die alleen een display op Compartiment 1 hebben, wordt het menudisplay van Compartiment 1 gebruikt om informatie voor eventuele andere compartimenten van de opladers weer te geven. De verbetering in versie V1.05 blijft.

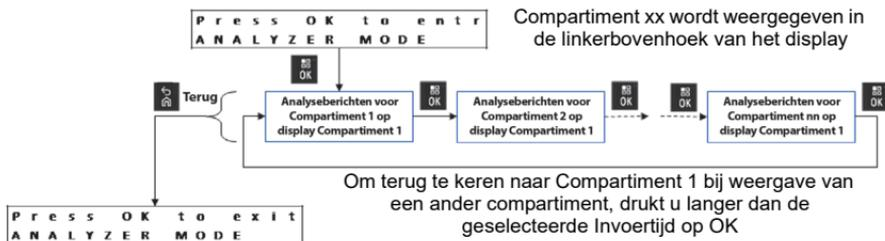

**Afbeelding 17:** Versie V1.11.01 van het analysemodusmenu

## Verwisselen van batterijen in een compartiment

Als er een batterij is verwijderd waarna dezelfde of een andere batterij in hetzelfde compartiment is geplaatst, dan is de parameter die voor de tweede batterij wordt weergegeven dezelfde parameter als die voor de eerste batterij werd weergegeven.

`Battery IMPRES Cycles` wordt bijvoorbeeld weergegeven voor een IMPRES 2- of IMPRES-batterij. Deze batterij is verwijderd uit het compartiment. Er is een andere IMPRES 2- of IMPRES-batterij in hetzelfde compartiment geplaatst. De eerste parameter die wordt weergegeven voor de tweede batterij is `Battery IMPRES Cycles`.

Maar bij de tweede batterij wordt mogelijk niet de parameter weergegeven die voor de eerste batterij is weergegeven. In dit geval wordt het identificatiebericht voor de tweede batterij weergegeven.

# IMPRES 2-batterij

## Display naast compartiment

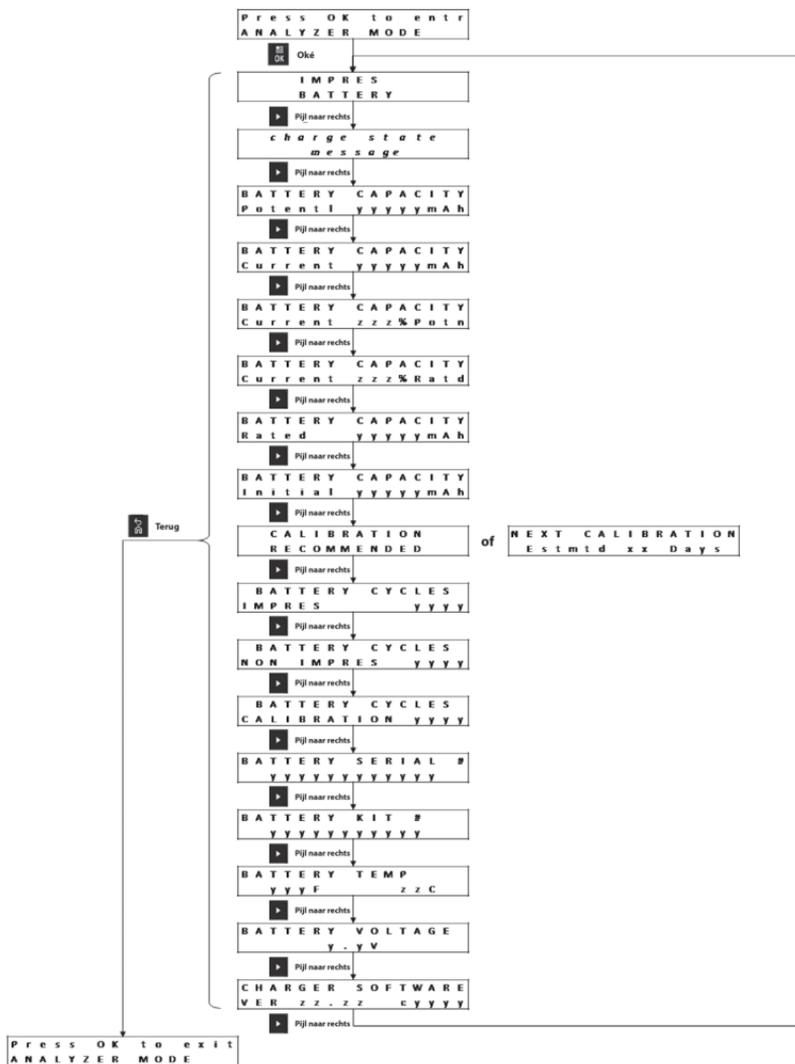

Nederlands

Afbeelding 18: IMPRES 2-batterij-analyzermodusmenu voor display naast compartiment

## Compartiment 1 geeft ander compartiment weer

Compartiment xx wordt weergegeven in de linkerbovenhoek van het display

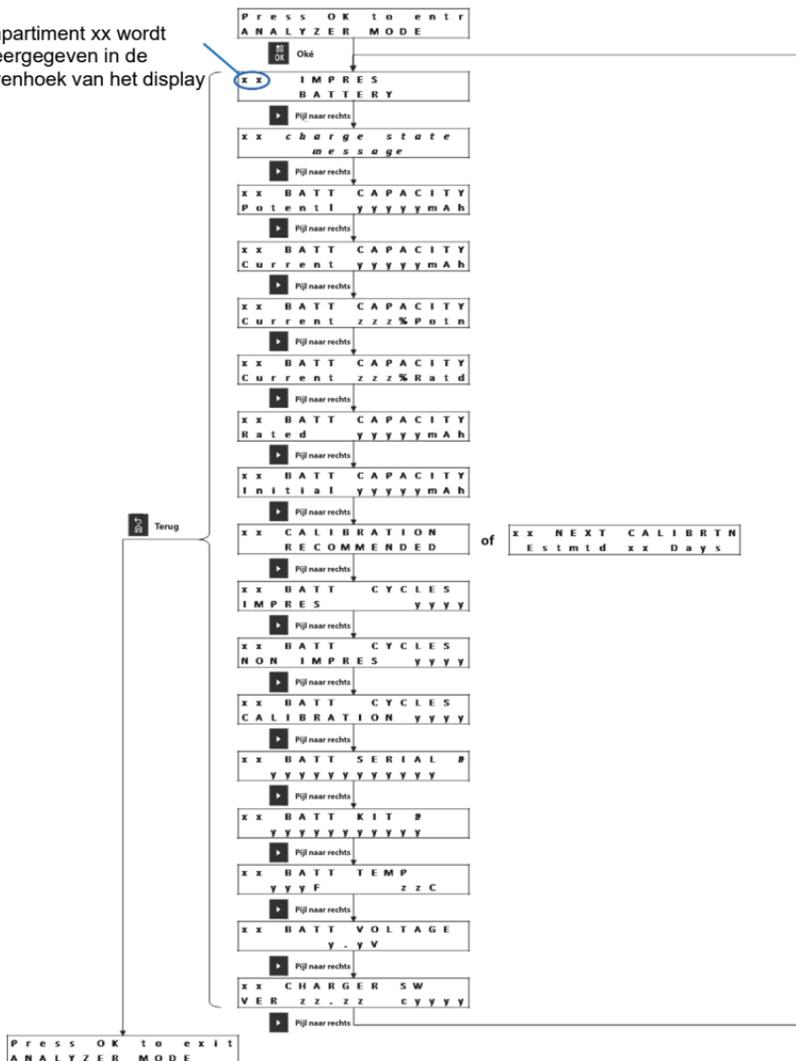

Afbeelding 19: IMPRES 2-batterij-analyzermodusmenu voor een ander compartiment (niet Compartiment 1)

# IMPRES-batterij

## Display naast compartiment

Nederlands

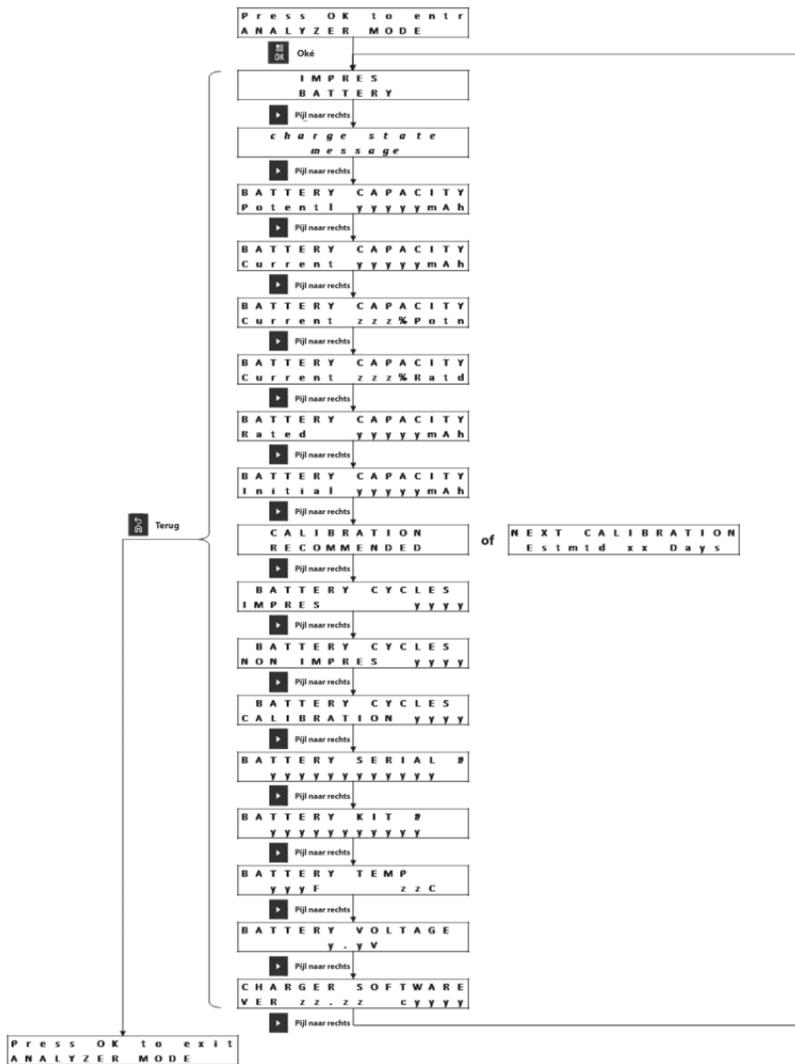

Afbeelding 20: IMPRES-batterij-analyzermodusmenu voor display naast compartiment

# Compartiment 1 geeft ander compartiment weer

Compartiment xx wordt weergegeven in de linkerbovenhoek van het display

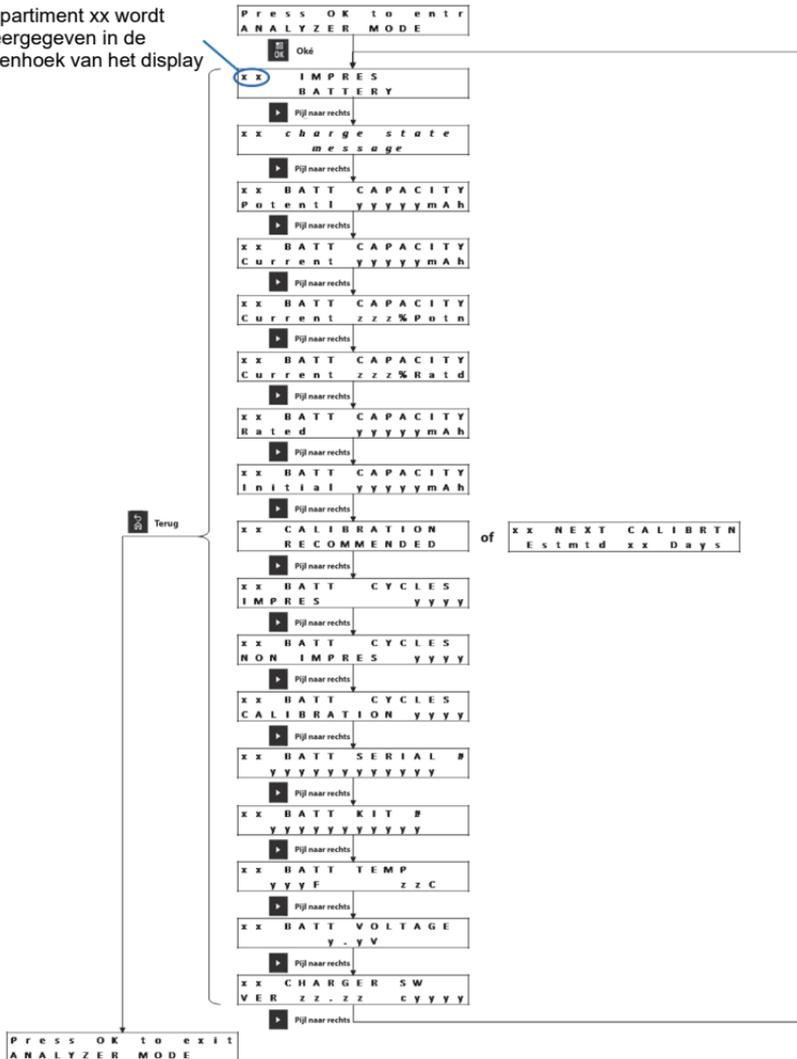

Afbeelding 21: IMPRES-batterij-analyzermodusmenu voor een ander compartiment (niet Compartiment 1)

# Andere Motorola Solutions-batterij

## Display naast compartiment

Nederlands

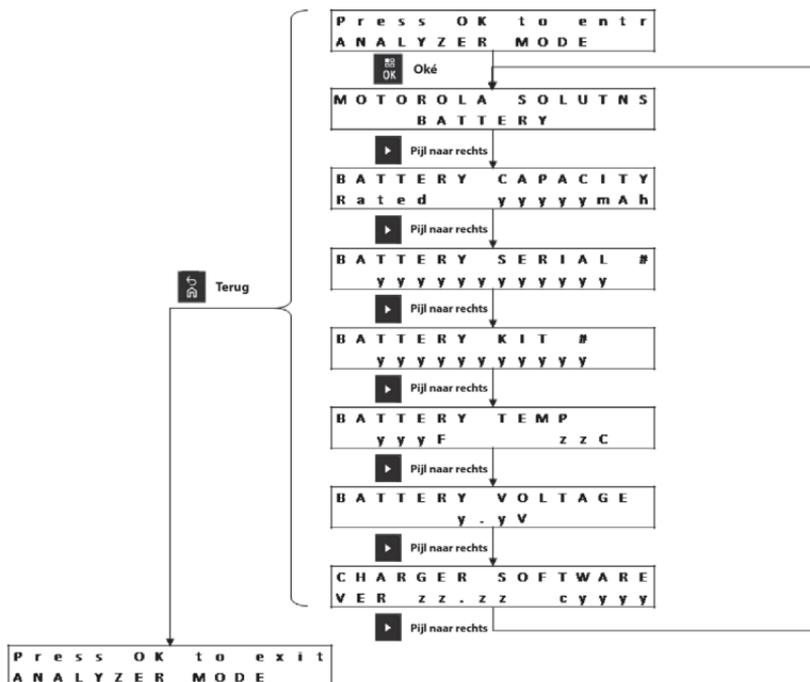

**Afbeelding 22:** Andere Motorola Solutions-batterij-analyzermodusmenu voor display naast compartiment



## Compartiment 1 geeft ander compartiment weer

Compartiment xx wordt weergegeven in de linkerbovenhoek van het display

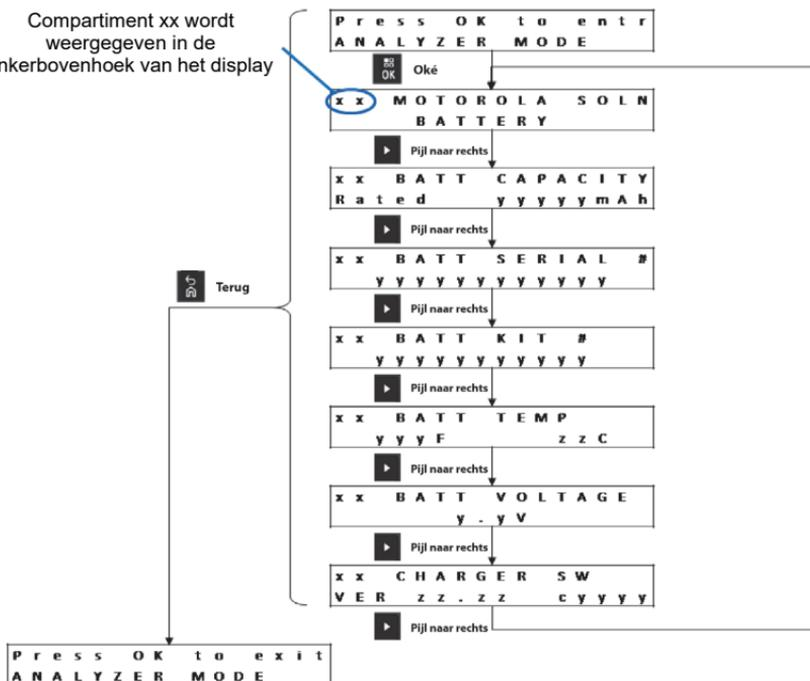

**Afbeelding 23:** Andere Motorola Solutions-batterij-analyzermodusmenu voor een ander compartiment (niet Compartiment 1)

## Onbekende batterij

### Display naast compartiment

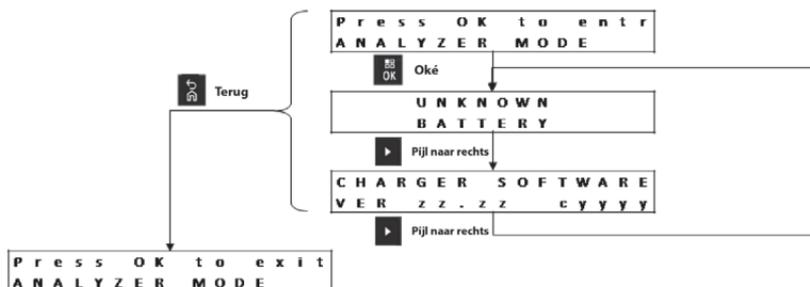

**Afbeelding 24:** Onbekende batterij-analyzermodusmenu voor display naast compartiment

### Compartiment 1 geeft ander compartiment weer

Compartiment xx wordt weergegeven in de linkerbovenhoek van het display

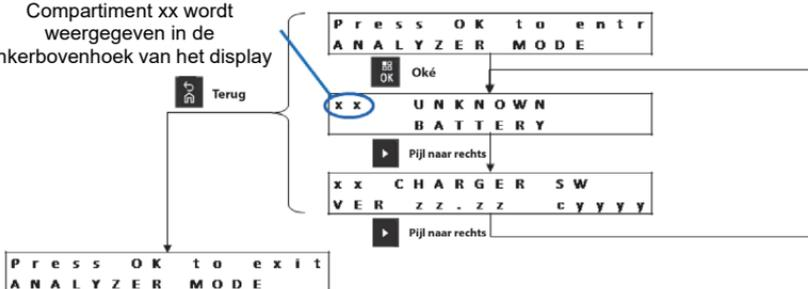

**Afbeelding 25:** Onbekende batterij-analyzermodusmenu voor een ander compartiment (niet Compartiment 1)

## Leeg compartiment

### Display naast compartiment

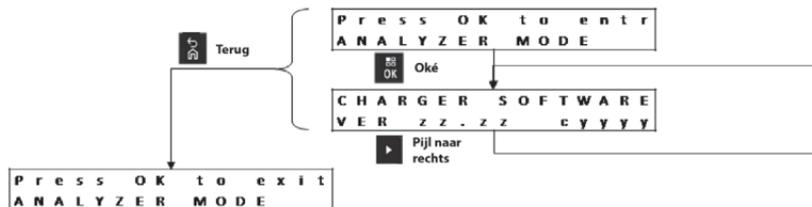

**Afbeelding 26:** Analysermodusmenu voor leeg compartiment naast display

### Compartiment 1 geeft ander compartiment weer

Compartiment xx wordt weergegeven in de linkerbovenhoek van het display

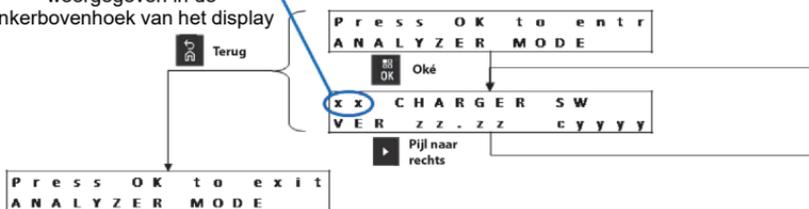

**Afbeelding 27:** Analysermodusmenu voor een leeg compartiment (niet Compartiment 1)

## Bericht opladerstatus

Sommige IMPRES 2-batterijen zijn uitgerust met een slaapstand. Aan het einde van Ship Lithium (Lithium verzenden), xx% Long-Term Storage (langdurige opslag) of 75% Long-Term Storage wordt de batterij met slaapstand in slaap gebracht. Met het bericht opladerstatus in de analysermodus kunt u zien wat de oplaadstatus van slapende batterijen is.

**Tabel 21:** Ship Lithium ingeschakeld en de batterij is klaar met opladen voor Ship Lithium

Display naast compartiment	Compartiment 1 geeft ander compartiment weer
SHIP LI SLEEP xxx% Rated Cap	xx SHIP LI SLEEP xxx% Rated Cap

**Tabel 22:** xx% Long-Term Storage ingeschakeld en de batterij is klaar met xx% opladen voor Long-Term Storage

Display naast compartiment	Compartiment 1 geeft ander compartiment weer
STORAGE SLEEP xxx% Rated Cap	xx STORAGE SLEEP xxx% Rated Cap

Het Bericht opladerstatus wordt bijvoorbeeld niet weergegeven als xx% Long-Term Storage is ingeschakeld en de batterij 75% Long-Term Storage in een andere oplader is opgeladen.

## Herprogrammering van de oplader

Voor het herprogrammeren van de oplader moet de communicatiemodule zijn aangesloten op een computer via een standaard USB-kabel. Als het IMPRES-batterij-  
fleetmanagementsysteem wordt gebruikt voor het starten van een herprogrammering, worden de volgende berichten weergegeven door de lader.

Verwijder de batterijen uit de ladercompartimenten vóór het herprogrammeren:

```
REPROGRAMMING  
REMOVE BATTERIES
```

Alle ladercompartimenten zijn leeg:

```
REPROGRAMMING  
WAITING FOR DATA
```

Het herprogrammeren van gegevens is bezig met downloaden:

```
REPROGRAMMING  
Progress yyy%
```

Voor opladers met een display voor elk compartiment, geeft de procentagewaarde het percentage van gegevens weer dat met succes is gedownload naar het compartiment dat hoort bij de display. Voor opladers die slechts één display hebben (compartiment 1) geeft de procentagewaarde het percentage van gegevens weer dat met succes is gedownload naar alle compartimenten.

Herprogrammeren mislukt in aangegeven compartiment:

```
REPROGRAMMING  
POCKET#xx FAILED
```

Het geïdentificeerde ladercompartiment start de normale activiteiten met behulp van de vorige software.

Het downloaden van herprogrammeringsgegevens is voltooid. Het opladen voltooit het herprogrammeringsproces.

```
IMPRES 2  
CHARGER
```

Herprogrammeringsproces voltooid.

```
REPROGRAMMING  
COMPLETE
```

De oplader start de normale activiteiten, met behulp van de nieuwe, gedownloade software. Door de gebruiker gedefinieerde instelling blijft gehandhaafd nadat de herprogrammering van de oplader voltooid is.

# Problemen met de oplader oplossen

**Tabel 23:** Probleemoplossing: Normaal opladen

Probleem	Oplossing...
<p>LED van compartiment knippert niet groen gedurende ongeveer 1 seconde bij inschakeling van de oplader.</p>	<p>Controleer of de stroomkabel goed is aangesloten op de oplader en op een geschikt stopcontact. Controleer ook of het stopcontact stroom ontvangt. Inspecteer zekeringen en vervang zo nodig.</p>
<p>De batterij of portfoon is in het compartiment geplaatst, maar de compartiment-LED blijft UIT en de batterij wordt niet aangeduid op het display ernaast.</p>	<p>Als het compartiment niet Compartiment 1 is en de Power Saver is ingeschakeld, drukt u op een Menu-knop. Zie hieronder.</p>
<p>Knipperende rode LED en op display (indien beschikbaar) staat: NOT CHARGEABLE REMOVE &amp; REINSERT of er bevindt zich een Motorola Solutions-batterij in het compartiment, maar op het display (indien beschikbaar) staat: UNKNOWN BATTERY</p> 	<p>Haal de batterij of portfoon uit het compartiment. Controleer de elektrische contactpunten van de batterij en het compartiment van de oplader op vervuiling, corrosie of fysieke schade. Controleer of de batterij door Motorola Solutions is goedgekeurd. Andere batterijen worden mogelijk niet opgeladen. Reinig de elektrische contactpunten van de batterij met een droge doek. Haal de oplader van de stroom en maak de elektrische contactpunten van het compartiment schoon met een droge doek. Probeer of het helpt om de batterij te vervangen. Als de storing dan weg is, stelt u de defecte batterij buiten werking. Als de storing aanhoudt met de vervangende batterij, stelt u de batterijoplader buiten werking.</p>
<p>Afwisselend rode/ groene LED aan het einde van kalibratie.</p> 	<p>De IMPRES 2- of IMPRES-batterij nadert mogelijk het einde van haar levensduur. De batterij is nog bruikbaar, maar de beschikbare capaciteit is wellicht niet geschikt voor intensief gebruik gedurende een langere periode. Alleen van toepassing op APX NEXT XN-batterij: Batterij is langer dan 10 minuten blootgesteld aan hoge temperaturen. Het wordt aanbevolen om deze batterij buiten gebruik te stellen.</p>

**Tabel 23: Probleemoplossing: Normaal opladen (vervolg)**

Probleem	Oplossing...
Afwisselend oranje/ groene LED gedurende ongeveer 4 seconden bij plaatsen van de batterij in de oplader.	De IMPRES 2- of IMPRES-batterij moet worden gekalibreerd/ gereviseerd. Plaats bij de eerst volgende gelegenheid de batterij in een IMPRES 2-oplader waarvoor kalibratie is ingeschakeld en laat de oplader de kalibratie afronden (onafgebroken groen).
In de analysemodus kan Compartiment 1 een ander compartiment weergeven.	De oplader is niet in staat het display op ten minste één van de andere compartimenten weer te geven.

**Tabel 24: Probleemoplossing: Opladen voor langdurige opslag**

Probleem	Oplossing...
Knipperende rode LED en op display (indien beschikbaar) staat: WRONG BATT TYPE CANNOT LT STORAGE of CANNOT DISCHARGE CANNOT LT STORAGE	Haal de batterij uit het batterijcompartiment. Zorg dat de batterij NIET is aangesloten op een portofoon. Zorg dat de batterij een IMPRES 2- of IMPRES-batterij is. Andere batterijen krijgen een batterijfout. Reinig de elektrische contactpunten van de IMPRES 2- of IMPRES-batterij met een droge doek. Haal de oplader van de stroom en maak de elektrische contactpunten van het compartiment schoon met een droge doek. Probeer de batterij te vervangen door een IMPRES 2- of IMPRES-batterij. Als de storing dan weg is, stelt u de defecte IMPRES 2- of IMPRES-batterij buiten werking. Als de storing aanhoudt met de vervangende IMPRES 2- of IMPRES-batterij, stelt u de batterijoplader buiten werking.
Knipperende rode LED en op display (indien beschikbaar) staat: STORE INCOMPLETE Lage capaciteit:yy%	De potentiële capaciteit van de IMPRES 2- of IMPRES-batterij kan minder zijn dan de selectie voor Long-Term Storage. De batterij nadert mogelijk het einde van haar levensduur.

**Tabel 24: Probleemoplossing:**  
Opladen voor langdurige opslag (vervolg)

Probleem	Oplossing...
<p>Knipperende rode LED en op display (indien beschikbaar) staat:</p> <p>RADIO POCKET CANNOT LT STORAGE</p> <p>of</p> <p>CHARGING POCKET CANNOT LT STORAGE</p>	<p>Het opladercompartiment is niet het standaardcompartiment voor het opladen van een batterij (via elektrische contactpunten tussen de oplader en de batterij).</p> <ul style="list-style-type: none"> <li>Een portofooncompartiment (Radio Pocket) is een speciaal vakje waarin de batterij is aangesloten op een portofoon. Er zitten geen externe contactpunten op de batterij en de batterij wordt opgeladen via elektrische contactpunten op de portofoon.</li> <li>Een opladercompartiment is een vakje dat oplaadenergie gebruikt voor een speciaal doeleinde, zoals USB-oplaadpoorten.</li> </ul> <p>Verplaats de batterij naar een standaardcompartiment of vervang het portofooncompartiment of opladercompartiment door een standaardcompartiment.</p>

**Tabel 25: Probleemoplossing: Opladen voor Ship Lithium**

Probleem	Oplossing...
<p>Knipperende rode LED en op display (indien beschikbaar) staat:</p> <p>WRONG BATT TYPE CANNOT SHIP LI</p>	<p>Haal de batterij uit het batterijcompartiment. Zorg dat de batterij NIET is aangesloten op een portofoon.</p> <p>Zorg dat de batterij een IMPRES 2-, IMPRES- of andere originele Motorola Solutions lithium-ion batterij is. Andere batterijen krijgen een batterijfout.</p> <p>Maak de elektrische contactpunten van de IMPRES 2-, IMPRES-, of andere goedgekeurde Motorola Solutions lithium-ion batterij schoon met een droge doek.</p> <p>Haal de oplader van de stroom en maak de elektrische contactpunten van het compartiment schoon met een droge doek.</p> <p>Probeer de batterij te vervangen met een andere IMPRES 2-, IMPRES- of andere originele Motorola Solutions lithium-ion batterij. Als de storing dan weg is, stelt u de defecte IMPRES 2-, IMPRES-batterij of andere goedgekeurde Motorola Solutions lithium-ion batterij buiten werking.</p> <p>Als de storing aanhoudt met de vervangende IMPRES 2-, IMPRES-batterij of andere goedgekeurde Motorola Solutions lithium-ion batterij, stelt u de batterijoplader buiten werking.</p>



**Tabel 25: Probleemoplossing: Opladen voor Ship Lithium (vervolg)**

Probleem	Oplossing...
Knipperende rode LED en op display (indien beschikbaar) staat: SHIP INCOMPLETE Lage capaciteit:yy% 	De potentiële capaciteit van de originele Motorola Solutions lithium-ion batterij kan minder zijn dan de Ship Lithium-limiet. De batterij nadert mogelijk het einde van haar levensduur.
Knipperende rode LED en op display (indien beschikbaar) staat: RADIO POCKET CANNOT LT STORAGE of CHARGING POCKET CANNOT SHIP LI 	Het opladercompartiment is niet het standaardcompartiment voor het opladen van een batterij (via elektrische contactpunten tussen de oplader en de batterij). <ul style="list-style-type: none"> <li>• Een portofooncompartiment (Radio Pocket) is een speciaal vakje waarin de batterij is aangesloten op een portofoon. Er zitten geen externe contactpunten op de batterij en de batterij wordt opgeladen via elektrische contactpunten op de portofoon.</li> <li>• Een opladercompartiment is een vakje dat oplaadenergie gebruikt voor een speciaal doeleinde, zoals USB-oplaadpoorten.</li> </ul> Verplaats de batterij naar een standaardcompartiment of vervang het portofooncompartiment of opladercompartiment door een standaardcompartiment.

## IMPRES-batterij-fleetmanagementsysteem

De software van het IMPRES-batterij-fleetmanagementsysteem verzamelt automatisch belangrijke gegevens van IMPRES- of IMPRES 2-batterijen die in een IMPRES-oplader worden geplaatst. Deze belangrijke gegevens omvatten leeftijd, capaciteit, oplaad- en kalibratie-/revisiegeschiedenis, productiedatum en datum van ingebruikname. De software van het IMPRES-batterij-fleetmanagementsysteem analyseert batterijgegevens, communiceert de batterijtoestand en adviseert wanneer de batterij moet worden vervangen. Als gevolg daarvan kunt u snel en efficiënt bepalen of de batterij wel of niet kan worden toegewezen aan een minder veeleisende gebruiker, wanneer u een nieuwe batterij moet kopen of wanneer u een ontbrekende batterij moet zoeken.

IMPRES-batterij-fleetmanagement levert belangrijke informatie over de batterij(en):

- Wanneer de batterijcapaciteit onder een aanvaardbaar minimum komt.
- Helpt ervoor te zorgen dat gebruikers voldoende capaciteit hebben voor een volledige ploegendienst.
- Geeft aan welke batterijen een lage capaciteit hebben, zodat deze buiten gebruik kunnen worden gesteld.
- Elimineert onverwachte stilstandtijd en werkonderbrekingen.
- Voorkomt de kosten van het voortijdig weggooien van batterijen.
- Controleert of de opladers optimaal worden gedistribueerd en gebruikt.

De IMPRES-batterij-fleetmanagementsoftware is schaalbaar van één locatie tot een netwerksysteem voor meerdere locaties, zoals wordt weergegeven in Afbeelding 28. Het IMPRES-batterij-fleetmanagementsysteem ondersteunt:

- Eén systeembeheerdersserver
- 19 externe clients
- 25 IMPRES-opladers of IMPRES-batterijlezers per client
- 25.000 IMPRES-batterijen in dezelfde locatie of in geografisch verspreide gebieden (het totale aantal batterijen voor het hele systeem mag niet meer dan 25.000 zijn).

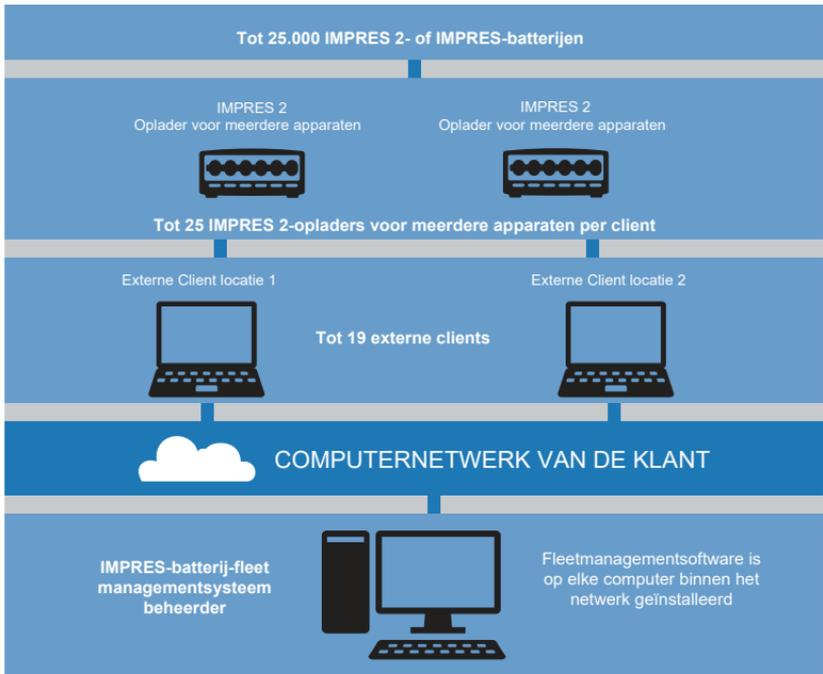

**Afbeelding 28:** IMPRES-batterijmanagement via netwerkopladers  
 IMPRES-batterij-fleetmanagement bestaat uit drie hoofdonderdelen:

- De toepassingssoftware.
- Een softwarelicentiecode.
- Een USB-kabel om de IMPRES 2-oplader, IMPRES 2-communicatiemodule, IMPRES-interface voor oplader (CIU) of IMPRES-batterijgegevenslezer te verbinden met een computer die een remote client host.

Maak gebruik van bestaande rapporten en pas nieuwe aan om de meest relevante informatie voor uw organisatie te zien. Gegevens worden opgeslagen in uw database en kunnen worden geëxporteerd naar een Excel™-bestand of worden afgedrukt. De IMPRES-batterij-fleetmanagementsoftware registreert en organiseert een verscheidenheid aan gegevens dus u kunt:

- Een momentopname bekijken van uw gehele batterijvloot.
- Beoordelen of batterijen voldoen aan uw prestatiecriteria.
- Bepalen wanneer de batterijen bijna aan het einde van de levensduur zijn.
- Nauwkeurig bepalen wanneer u nieuwe batterijen koopt.
- Een rapport over verloren batterijen ontvangen.
- Gebruik van uw opladers optimaliseren.
- Alle apparaten in het systeem bewaken.

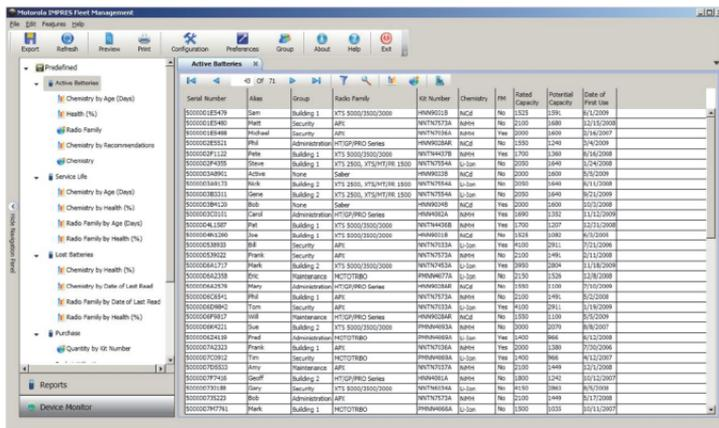

Afbeelding 29: Rapport actieve batterijen

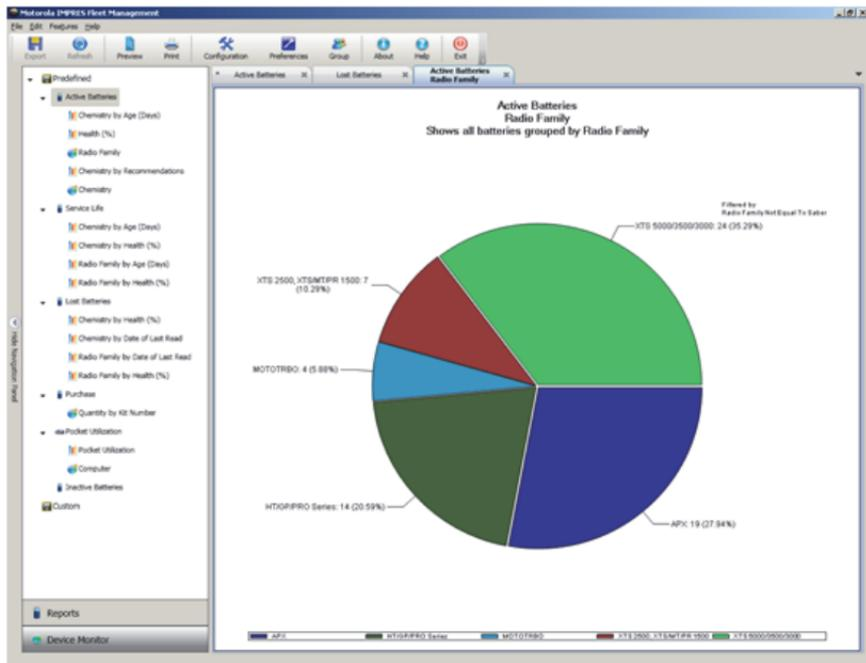

**Afbeelding 30:** Batterijen in gebruik door portfoonfamilie

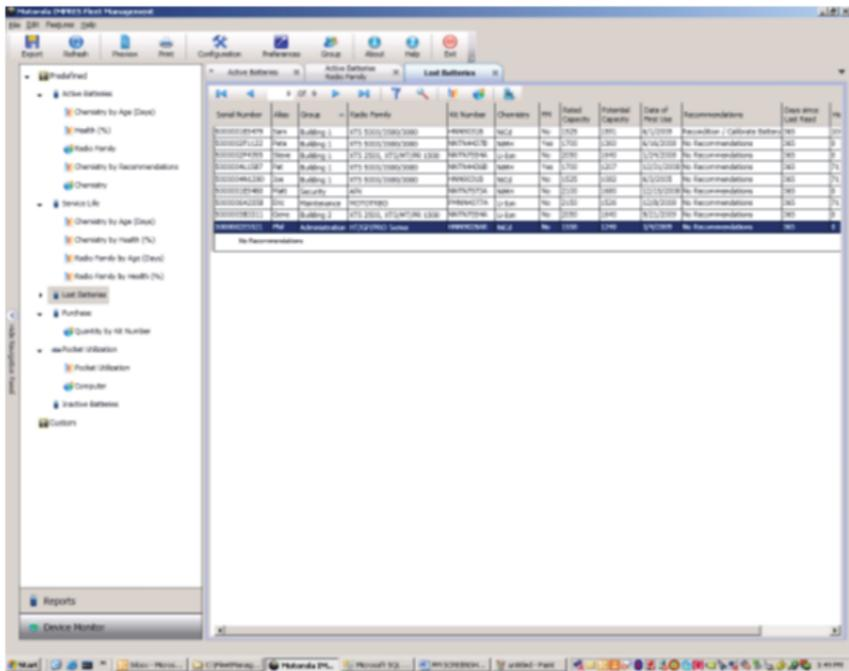

Afbeelding 31: Verloren batterijen per locatie

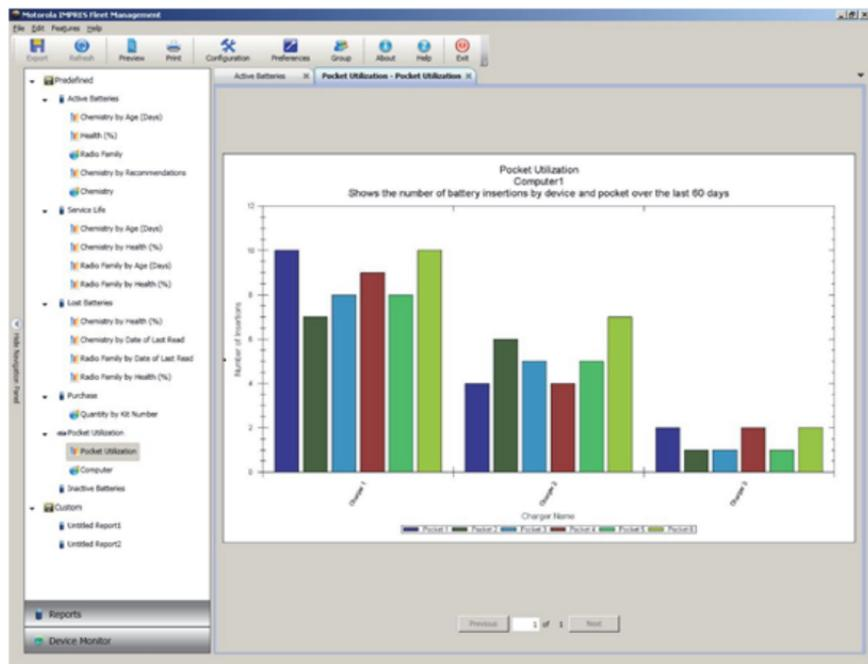

**Afbeelding 32:** Gebruik van opladercompartimenten

## Wandmontage voor oplader voor meerdere apparaten

Een beugel voor wandmontage (onderdeelnummer: 0705559L01) is beschikbaar voor de oplader voor meerdere apparaten. Neem contact op met uw lokale dealer om dit artikel te bestellen. De installatie wordt hieronder weergegeven.



WAARSCHUWING

- Deze steun voor wandmontage moet door een getrainde en ervaren technicus worden geïnstalleerd. Als u het product door een niet-gespecialiseerde technicus laat installeren, kan dit zeer gevaarlijk zijn en leiden tot schade of letsel.
- Installeer het product niet op een plaats waar het gewicht niet kan worden ondersteund. Als de plaats waar de steun voor wandmontage wordt geïnstalleerd niet stevig genoeg is, kan deze vallen en letsel veroorzaken.
- Installeer de steun niet op een plaats waar kans bestaat op trillingen, beweging, of slagen of stoten.

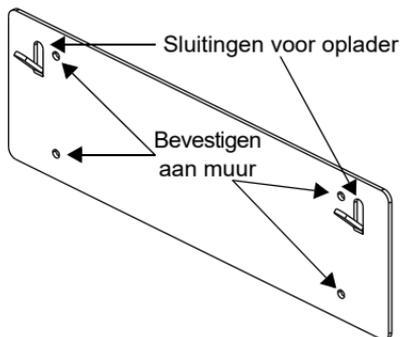

Beugel

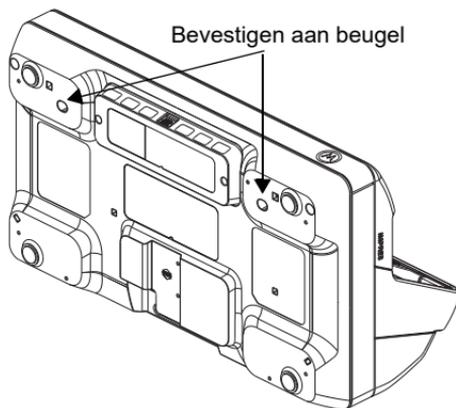

Oplader

**Afbeelding 33:** Beugelmontagegaten en sluitingsposities



## De oplader voor meerdere apparaten aan de muursteun monteren

1. Plaats de steun voor wandmontage in de gewenste positie en markeer de plaats voor de montagegaten op de muur.



Let op

Controleer of er zich in het gebied achter het montageoppervlak geen elektrische bedrading, kabels en buizen bevinden voordat u gaat snijden, boren of de montageschroeven gaat plaatsen.

2. Monteer de steun aan de muur met behulp van de bijbehorende montagehardware voor het type muur waaraan deze moet worden bevestigd. Boor een aantal gaten op basis van de markeringen op de muur.
3. Breng de muursteun in positie door de montagehardware boven de montagegaten op de muursteun stevig vast te zetten.

**Opmerking:** Het wordt aanbevolen dat u een zelfborende schroef van 10-16x1,5 inch en sluitring (niet meegeleverd) gebruikt op houten steunen en een effen-betonnen/bakstenen muur.

4. Hang de oplader voor meerdere apparaten aan de muursteun.

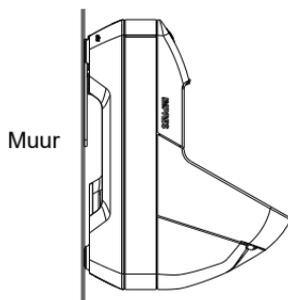

**Afbeelding 34:** Oplader gemonteerd op muursteun

# ВАЖЛИВІ ПРАВИЛА ТЕХНІКИ БЕЗПЕКИ

## Збережіть ці інструкції

Цей документ містить важливі інструкції щодо техніки безпеки й експлуатації. Уважно прочитайте ці інструкції та збережіть їх для подальшого використання.

Перед початком використання зарядного пристрою для акумуляторів ознайомтеся з усіма інструкціями та попереджувальним маркуванням на 1) зарядному пристрої, 2) акумуляторі та 3) радіостанції, з якою використовується акумулятор.

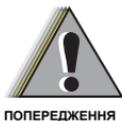

1. Щоб уникнути пошкодження шнура електроживлення, під час від'єднання від зарядного пристрою або розетки змінного струму тягніть за вилку, а не за шнур.
2. Використовувати подовжувач слід лише в разі крайньої потреби. Використання подовжувача, що не відповідає вимогам, може стати причиною займання або враження електричним струмом. Якщо необхідно використовувати подовжувач, це має бути кабель діаметром 18 AWG й довжиною не більше 2,0 м (6,5 фути) або діаметром 16 AWG й довжиною не більше 3,0 м (9,8 фути).
3. Щоб зменшити ризик займання, ураження електричним струмом або травмування, не використовуйте несправні або пошкоджені зарядні пристрої. Передайте їх до сертифікованого представництва компанії Motorola Solutions із сервісного обслуговування.
4. Не розбирайте зарядний пристрій. Під час розбирання зарядного пристрою існує ризик ураження електричним струмом і займання. Ремонту або заміні підлягають лише адаптери для гнізд заряджання (номери за каталогом NNTN9212 і NNTN9213). Дотримуйтесь інструкцій із використання комплекту адаптерів для гнізд заряджання MN005697A01 для багатомісного зарядного пристрою IMPRES 2 серії APX.
5. Щоб зменшити ризик ураження електричним струмом, перед проведенням будь-яких операцій із технічного обслуговування або очищення відключайте зарядний пристрій від розетки змінного струму.

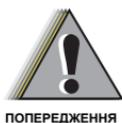

6. Щоб зменшити ризик ушкоджень, використовуйте тільки акумулятори, схвалені компанією Motorola Solutions (див. Табл. 2). Інші акумулятори є вибухонебезпечними й можуть призвести до травмування або пошкодження майна.

7. Використання аксесуарів, не рекомендованих компанією Motorola Solutions, може призвести до займання, ураження електричним струмом або травмування.

## Інструкція з безпечної експлуатації

- Цей пристрій призначений для використання лише всередині приміщень. Використовуйте його лише в сухих приміщеннях і не допускайте впливу вологи.
- Максимальна температура середовища навколо зарядного пристрою не повинна перевищувати 40 °C (104 °F).
- Радіостанцію, вставлену в зарядне гніздо, можна вмикати лише для бездротової передачі даних, наприклад у мережі Wi-Fi. В іншому випадку вона має залишатися вимкненою.
- Підключайте зарядний пристрій лише до мережі живлення з відповідними характеристиками (див. Табл. 3).
- Розетка змінного струму має бути розташована поруч у легкодоступному місці.
- Переконайтеся, що шнур живлення розташовано в місці, де на нього неможливо наступити, перечепитися через нього, а також виключено контакт із водою та можливість механічних пошкоджень.
- Підключайте шнур живлення лише до розеток мережі змінного струму з плавкими запобіжниками та належним рівнем напруги (як зазначено на виробі).
- Для відключення від мережевої напруги від'єднайте шнур живлення від розетки змінного струму.
- Кількість зарядних пристроїв, підключених до ланцюгів зі струмом 15 А або 20 А, не повинна перевищувати дозволене граничне значення для використовуваного сертифікованого подовжувача. НЕ РЕКОМЕНДОВАНО підключати один подовжувач до іншого. Навантаження на ланцюг не повинне перевищувати 80 % від номінального значення.
- Використовуйте лише гнізда для заряджання, схвалені компанією Motorola Solutions.

# Сумісні моделі

Табл. 1: Сумісні моделі та їхній опис

Модель	Опис
PS000029A01 (унів.) PS000029A04 (ЄС / Сполучене Королівство) PS000029A06 (Корея)	Багатомісний зарядний пристрій IMPRES 2 серії APX з 1 дисплеєм, програмою керування парком акумуляторів та можливістю перепрограмування зарядного пристрою
PS000029A02 (унів.) PS000029A05 (ЄС / Сполучене Королівство) PS000029A07 (Корея)	Багатомісний зарядний пристрій IMPRES 2 серії APX з 6 дисплеєм, програмою керування парком акумуляторів та можливістю перепрограмування зарядного пристрою
PS000029A03 (ЄС / Сполучене Королівство) PS000029A08 (Корея)	Багатомісний зарядний пристрій IMPRES 2 серії APX із 6 дисплеями, програмою керування парком акумуляторів, можливістю перепрограмування зарядного пристрою та USB-портом для заряджання
PS000337A01 (США / Північна Америка, Австралія / Нова Зеландія)	Багатомісний зарядний пристрій IMPRES 2 серії APX NEXT із 6 дисплеями, програмою керування парком акумуляторів та можливістю перепрограмування зарядного пристрою

## Акумулятори, схвалені компанією Motorola Solutions

Зарядні пристрої IMPRES 2 серії APX гарантовано заряджатимуть акумулятори, перелічені в Табл. 2. Вони можуть заряджатися як разом із радіостанцією, так і окремо.

Табл. 2: Акумулятори, схвалені компанією Motorola Solutions.

Комплект (№ за каталогом)	Опис
NNTN7033	IMPRES літій-іонний, FM, для небезпечних зон (HazLoc), IP67, 4100 мА·год
NNTN7034	IMPRES літій-іонний, IP67, 4200 мА·год
NNTN7035	IMPRES нікель-метал-гідридний, FM, для небезпечних зон (HazLoc), зносостійкий, 2000 мА·год
NNTN7036	IMPRES нікель-метал-гідридний, FM, для небезпечних зон (HazLoc), IP67, 2000 мА·год

**Табл. 2:** Акумулятори, схвалені компанією  
Motorola Solutions. (продовження)

Комплект (№ за каталогом)	Опис
NNTN7037	IMPRES нікель-метал-гідридний, IP67, 2100 мА·год
NNTN7038	IMPRES літій-іонний, IP67, 2900 мА·год
NNTN7573	IMPRES нікель-метал-гідридний, зносостійкий, 2100 мА·год
NNTN8092	IMPRES літій-іонний, FM, для небезпечних зон (HazLoc), зносостійкий, 2300 мА·год
NNTN8182	IMPRES літій-іонний, зносостійкий, 2900 мА·год
NNTN8921	IMPRES 2 літій-іонний, TIA4950, для небезпечних зон (HazLoc), зносостійкий, IP67, 3700 мА·год
NNTN8930	IMPRES 2 літій-іонний, TIA4950, для небезпечних зон (HazLoc), зносостійкий, IP67, 2700 мА·год
NNTN9087	IMPRES 2 літій-іонний, IP68, 3800 мА·год
NNTN9088	IMPRES 2 літій-іонний, DIVISION 2, для небезпечних зон (HazLoc), IP68, 3800 мА·год
NNTN9089	IMPRES 2 літій-іонний, IP68, 5650 мА·год
NNTN9090	IMPRES 2 літій-іонний, DIVISION 2, для небезпечних зон (HazLoc), IP68, 5650 мА·год
NNTN9126	IMPRES 2 літій-іонний, IP68, 4400 мА·год
NNTN9127	IMPRES 2 літій-іонний, DIVISION 2, для небезпечних зон (HazLoc), IP68, 4400 мА·год
PMNN4403	IMPRES літій-іонний, IP67, 2150 мА·год
PMNN4485	IMPRES 2 літій-іонний, зносостійкий, IP67, 2500 мА·год
PMNN4486	IMPRES 2 літій-іонний, зносостійкий, IP67, 3400 мА·год
PMNN4487	IMPRES 2 літій-іонний, зносостійкий, IP67, 4400 мА·год
PMNN4494	IMPRES 2 літій-іонний, зносостійкий, IP67, 5000 мА·год
PMNN4504	IMPRES 2 літій-іонний, DIVISION 2, для небезпечних зон (HazLoc), зносостійкий, IP67, 3400 мА·год
PMNN4505	IMPRES 2 літій-іонний, DIVISION 2, для небезпечних зон (HazLoc), зносостійкий, IP67, 4850 мА·год
PMNN4547	IMPRES 2 літій-іонний, TIA4950, для небезпечних зон (HazLoc), зносостійкий, IP68, 3100 мА·год
PMNN4573	IMPRES 2 літій-іонний, TIA4950, для небезпечних зон (HazLoc), зносостійкий, IP68, 4600 мА·год

**Табл. 2:** Акумулятори, схвалені компанією Motorola Solutions. (продовження)

Комплект (№ за каталогом)	Опис
PMNN4812	Літій-іонний акумулятор APX NEXT XN IMPRES 2, DIV 2, для небезпечних зон (HAZLOC), IP68, 3400 мА·год

## Джерела живлення, схвалені компанією Motorola Solutions

**Табл. 3:** Джерела живлення, схвалені компанією Motorola Solutions

Комплект (№ за каталогом)	Опис
3087791G01	Шнур живлення, США / Північна Америка
3087791G04	Шнур живлення, ЄС
3087791G07	Шнур живлення, Сполучене Королівство / Гонконг
3087791G10	Шнур живлення, Австралія / Нова Зеландія
3087791G13	Шнур живлення, Аргентина
3087791G16	Шнур живлення, Корея
3087791G20	Шнур живлення, Японія
3087791G22	Шнур живлення, Бразилія
CB000460A01	Шнур живлення, Китай

## Модулі передачі даних, схвалені компанією Motorola Solutions

**Табл. 4:** Модулі передачі даних, схвалені компанією Motorola Solutions

Комплект (№ за каталогом)	Опис
AS000013A01	Модуль перепрограмування зарядного пристрою IMPRES 2 й керування парком акумуляторів
AS000012A02	Модуль перепрограмування зарядного пристрою IMPRES 2, керування парком акумуляторів і заряджання пристроїв

## Зарядний пристрій, гнізда та модуль обміну даними

Система адаптивного заряджання IMPRES 2™ серії APX забезпечує повний цикл обслуговування акумуляторів у повністю автоматичному режимі. Зарядний пристрій має такі особливості:

- Адаптивне заряджання різних типів акумуляторів, як-от IMPRES 2, IMPRES™ й інших оригінальних акумуляторів Motorola Solutions.
- Гніздо, яке пристосоване для заряджання або акумулятора окремо, або радіопристрою з приєднаним акумулятором.
- Світлодіодні індикатори червоного, жовтого та зеленого кольору повідомляють про стан зарядного гнізда.
- Модуль обміну даними
  - Перепрограмування зарядного пристрою
  - Передавання даних акумулятора IMPRES 2 або IMPRES до системи керування парком акумуляторів IMPRES
  - (Додаткове обладнання) шість USB-портів типу А по 0,5 А для заряджання USB-пристроїв
- Меню, кероване з клавіатури
  - Налаштування зарядного пристрою
  - Аналіз стану акумулятора
- Інформаційний дисплей на гнізді № 1
  - Додаткові дисплеї на інших гніздах
- Підготування акумуляторів типів IMPRES 2 чи IMPRES до тривалого зберігання окремо від радіостанції або підготування окремого літій-іонного акумулятора Motorola Solutions до транспортування. НЕ МОЖНА залишати акумулятори в зарядному пристрої після здійснення підготовки до тривалого зберігання або підготовки літій-іонних акумуляторів до транспортування.
- Функції енергозбереження
  - Відповідно до стандартів, запроваджених Каліфорнійською комісією з енергетики для пристроїв заряджання акумуляторів малого розміру. Зарядні гнізда автоматично переходять у режим сну та активуються за будь-якої дії користувача або коли в гніздо вставляється акумулятор.

- Відповідно до обмежень ЄС щодо споживання електроенергії приладами в режимі очікування (комплект зарядного пристрою європейського зразка). Якщо в режимі «Power Saver» (Енергозбереження) протягом певного часу не відбувається жодних подій, усі зарядні гнізда (окрім гнізда № 1) автоматично вимикаються. Після натискання будь-якої кнопки на клавіатурі їхнє живлення відновлюється.

- Висока ефективність заряджання літій-іонних акумуляторів IMPRES 2.
- Скорочений час заряджання.
- Подовжений термін служби акумулятора.

Не рекомендується використовувати радіостанцію, коли вона перебуває в зарядному пристрої.

В іншому разі можливе незначне зниження якості прийому та збільшення тривалості заряджання.

Під час калібрування/відновлення акумулятор повністю розряджається, а потім повністю заряджається. Це може призвести до вимкнення радіостанції на етапі розряджання. Перед тим як виконувати калібрування акумулятора, рекомендується від'єднати радіопристрій або вимкнути його.

## **Акумулятори й зарядні пристрої IMPRES 2 та IMPRES**

### **Можливості й переваги**

Для енергозабезпечення IMPRES 2 використовується інноваційна енергетична система Tri-Chemistry, розроблена компанією Motorola Solutions. Складовими цієї системи є:

- акумулятори IMPRES 2 і IMPRES;
- адаптивний зарядний пристрій IMPRES 2;
- радіостанції IMPRES.

Заряджання акумуляторів IMPRES 2 або IMPRES за допомогою адаптивного зарядного пристрою IMPRES 2, який регулярно здійснює їх калібрування й відновлення, має перелічені далі переваги.

- Подовження терміну служби акумулятора.



- Вимірювання ємності акумулятора й визначення поточного рівня заряду повідомляє про залишок часу ефективного використання.
- Відстеження типових сценаріїв використання акумулятора IMPRES 2 або IMPRES.
- Оновлення даних про особливості використання, які зберігаються в акумуляторі IMPRES 2 або IMPRES.
- Автоматичне калібрування/відновлення суто за потреби.
- Запобігання нагріванню акумулятора IMPRES 2 або IMPRES незалежно від того, як довго він перебуває в гнізді зарядного пристрою.
- Періодичне поповнення заряду акумуляторів, вставлених у гнізда пристрою, що завжди підтримує їх у стані повної готовності до роботи.
- Відсутність ефекту пам'яті нікелевих акумуляторів, що позбавляє необхідності купувати спеціальне обладнання або навчати персонал методикам підтримки працездатності акумуляторів.

Унікальна патентована система позбавляє необхідності відстежувати й реєструвати стан акумуляторів IMPRES 2 або IMPRES, вручну проводити калібрування/відновлення або своєчасно виймати акумулятори з зарядних пристроїв після завершення заряджання.

## Ініціалізація акумуляторів IMPRES 2 або IMPRES

Для забезпечення повної функціональності нові акумулятори IMPRES 2 або IMPRES потрібно ініціалізувати за допомогою зарядного пристрою. Він автоматично розпізнає нові акумулятори IMPRES 2 або IMPRES і так само автоматично починає їх ініціалізацію. Ініціалізацією є перше калібрування/відновлення акумулятора IMPRES 2 або IMPRES. Цей процес відбувається у два етапи. Перший етап – це розрядження акумулятора; світлодіод індикації стану постійно світиться **жовтим**. Другий етап – заряджання до максимального рівня; світлодіод постійно світиться **зеленим**. Цей процес може тривати до 12 годин, залежно від рівня залишкового заряду та ємності акумулятора. Якщо процес переривається на будь-якому з етапів, ініціалізація відкладається до наступного сеансу заряджання.

## Пам'ять стану заряджання для IMPRES 2 або IMPRES

Під час заряджання акумуляторів IMPRES 2 або IMPRES зарядний пристрій IMPRES 2 або IMPRES зберігає інформацію про стан заряджання в пам'яті акумулятора. Якщо вийняти акумулятор IMPRES 2 або IMPRES з одного гнізда зарядного пристрою IMPRES 2 або IMPRES і не пізніше ніж за 30 хвилин вставити його в інше чи те саме гніздо, заряджання продовжиться з того етапу, на якому воно було перервано. Ця функція запобігає надлишковому заряджанню й уповільнює процес скорочення ресурсу акумулятора. Це є особливо актуальним для нікелевих акумуляторів.

## Автоматичне калібрування/відновлення акумулятора IMPRES 2 або IMPRES

Зарядні пристрої IMPRES 2 автоматично оцінюють стан акумуляторів IMPRES 2 або IMPRES. За результатами цієї оцінки так само автоматично відбувається калібрування або відновлення акумулятора. Переривання процесу на етапі розряджання або повного заряджання призводить до того, що калібрування відкладається до наступного сеансу заряджання.

Щоб увімкнути або вимкнути калібрування/відновлення, потрібно увійти до режиму налаштування зарядного пристрою. Якщо цю функцію вимкнено, а акумулятор IMPRES 2 або IMPRES потребує калібрування/відновлення, світлодіодний індикатор подасть сигнал, блимаючи **навперемінно жовтим і зеленим**, щойно акумулятор буде вставлено в гніздо й після завершення заряджання.

**Примітка.** Для здійснення автоматичного калібрування/відновлення акумулятор IMPRES 2 або IMPRES має перебувати поза гніздом зарядного пристрою більше 30 хвилин.

## Акумулятор IMPRES із функцією самокалібрування та відновлення



**УВАГА!** Акумулятори IMPRES 2, на етикетці яких є цей значок, не потребують періодичного калібрування та відновлення, коли вони вставлені в цей зарядний пристрій IMPRES 2 (з програмним забезпеченням версії 2.05 або новішої).

**Примітка.** Слідкуйте, щоб у вашому зарядному пристрої завжди було встановлено останню версію вбудованого програмного забезпечення. Пакет програм MSI Charger Reprogrammer можна завантажити з веб-сайту Motorola Online (MOL) або Motorola Solutions.

## Оновлення вбудованого програмного забезпечення

**Примітка.** Застосовується до всіх допоміжних або зарядних пристроїв IMPRES Gen 1 і Gen 2, до яких відносяться інтерфейсні блоки зарядного пристрою (CIU), зчитувачі даних акумулятора (BDR), одномісні зарядні пристрої (SUC), двомісні зарядні пристрої (DUC) і багатомісні зарядні пристрої (MUC).

Перед оновленням допоміжного або зарядного пристрою IMPRES до новішої версії вийміть із нього всі вставлені акумулятори.

1. Підключіть допоміжний або зарядний пристрій до комп'ютера, використовуючи USB-кабель. Підключений допоміжний або зарядний пристрій відобразиться в головному вікні програми MSI Charger Reprogrammer.

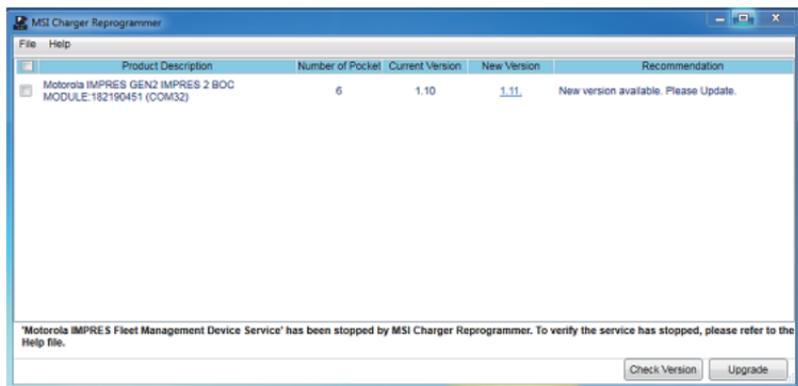

2. Натисніть кнопку Check Version (Перевірити версію), щоб знайти останню доступну версію програмного забезпечення на сервері MSI.

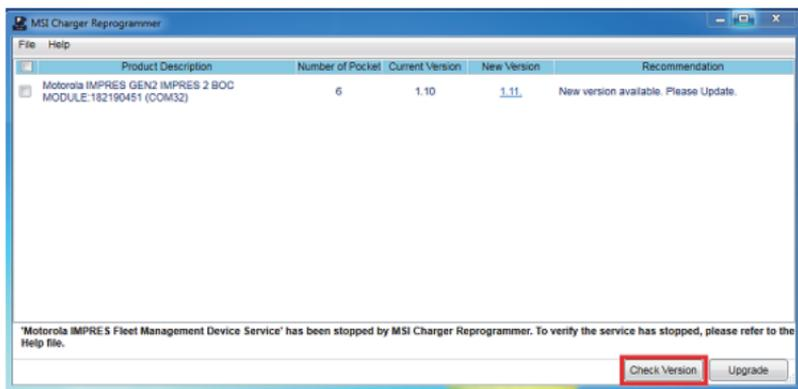

3. Виберіть допоміжний або зарядний пристрій, що потребує оновлення.

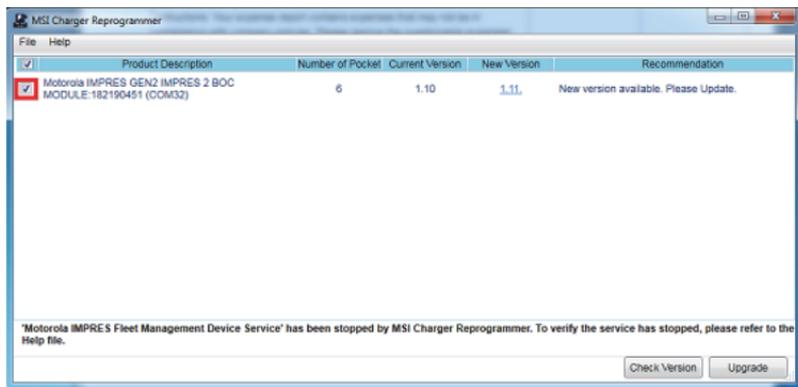

**Примітка.** Неможливо вибрати допоміжний або зарядний пристрій, який уже оновлено до останньої версії вбудованого програмного забезпечення.

4. Щоб запустити оновлення вбудованого програмного забезпечення, натисніть кнопку Upgrade (Оновити).

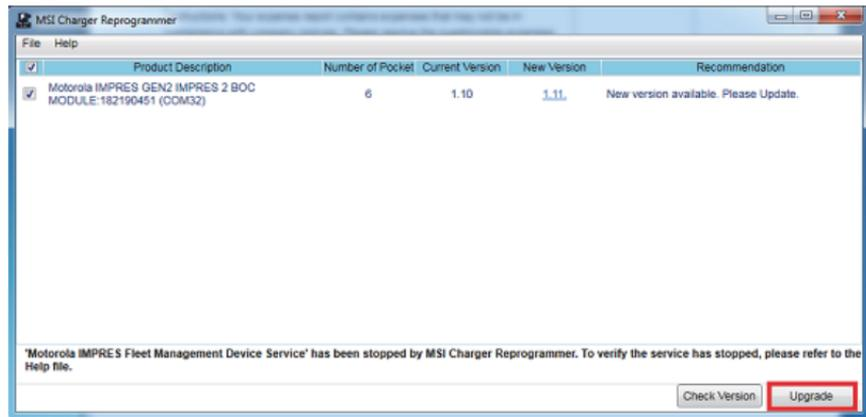

5. Коли буде запропоновано розпочати оновлення, у вікні підтвердження натисніть кнопку OK. У вікні відобразиться смуга ходу оновлення.

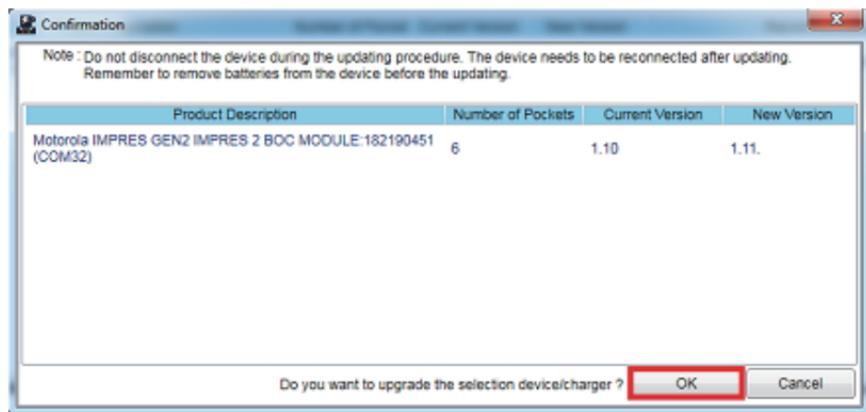

6. Після завершення всіх оновлень закрийте це вікно.

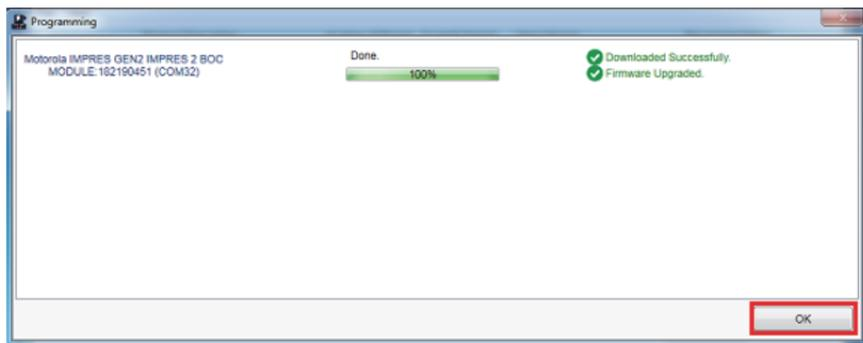

## Запуск калібрування/відновлення вручну



**УВАГА!** Процес ручного калібрування або відновлення не застосовується до акумуляторів IMPRES і IMPRES 2, позначених цим символом.

Хоча процес калібрування/відновлення зазвичай відбувається в автоматичному режимі, іноді виникають ситуації, коли його доцільно запустити вручну. Наприклад, індикатор на зарядному пристрої може блимати **навперемінно жовтим і зеленим** для акумулятора IMPRES 2 або IMPRES, подаючи сигнал, що в зарядному пристрої вимкнено функцію калібрування. Якщо цей акумулятор протягом 30 хвилин буде переміщено в зарядний пристрій з увімкненою функцією калібрування, останній стан заряджання залишиться актуальним, запобігаючи автоматичному запуску функції калібрування/відновлення.

Щоб вручну запустити процес калібрування/відновлення, вийміть акумулятор IMPRES 2 або IMPRES із зарядного пристрою на дві з половиною хвилини. Потім виконайте описані далі дії.

1. Вставте акумулятор у гніздо зарядного пристрою.
2. За дві з половиною хвилини вийміть його з гнізда.
3. Зачекайте 5 секунд і знову вставте акумулятор у зарядний пристрій.

Процес калібрування/відновлення почнеться одразу, зазвичай спочатку відбувається розрядження (**постійний жовтий**). Калібрування/відновлення вважається завершеним тільки після повного заряджання (**постійний зелений**).

## Переривання калібрування/відновлення вручну

На етапі розряджання акумуляторів IMPRES 2 або IMPRES (постійний жовтий) процес калібрування/відновлення можна в будь-який час перервати. Для цього виконайте такі дії:

1. Вийміть акумулятор із гнізда зарядного пристрою.
2. Зачекайте 5 секунд і знову вставте акумулятор у зарядний пристрій.

Розряджання одразу припиниться, і почнеться звичайне заряджання. Стан заряджання відобразиться за допомогою світлодіодного індикатора.

## Загальний огляд зарядного пристрою



Рис. 1: Загальний огляд зарядного пристрою

**Табл. 5:** Загальний огляд та опис зарядного пристрою

№	Назва	Опис
1–6	Зарядні гнізда	У кожне гніздо можна вставити сумісну радіостанцію чи акумулятор
7	Модуль обміну даними	У деяких зарядних пристроях модуль обміну даними також дає змогу заряджати USB-пристрої: <ul style="list-style-type: none"> <li>• PS000029A03 (ЄС / Сполучене Королівство)</li> <li>• PS000029A08 (Корея)</li> </ul>
8	Світлодіодний індикатор стану гнізда	Світлодіодний індикатор стану заряджання (один для кожного гнізда)
9	Дисплей	Додатковий дисплей для інших гнізд (окрім гнізда № 1)
10	Дисплей клавіатури	Дисплей гнізда № 1 із клавішами навігації по меню
11	Роз'єм живлення від мережі змінного струму	Потрібен шнур живлення для відповідної країни чи регіону

## Світлодіодна індикація закінчення терміну служби акумулятора IMPRES 2 або IMPRES

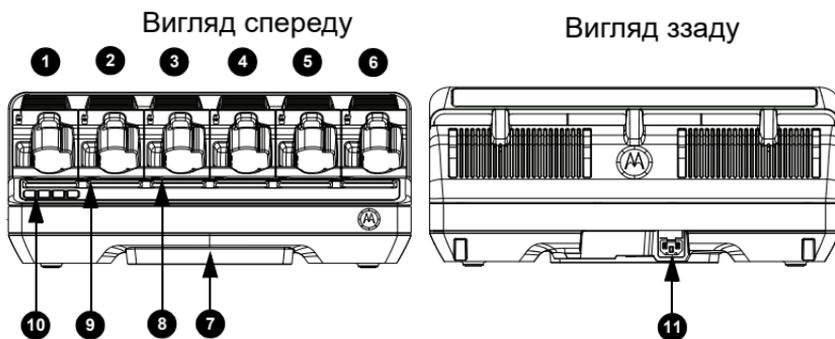
Після успішного завершення калібрування/відновлення зарядний пристрій може сигналізувати про закінчення терміну служби акумулятора IMPRES 2 або IMPRES (**навперемінно блимають червоний і зелений індикатори**).

У процесі експлуатації акумуляторів їхня ємність скорочується внаслідок природного зношування. Після завершення калібрування/відновлення зарядний пристрій порівнює ємність акумулятора IMPRES 2 або IMPRES із номінальним значенням. Якщо фактична ємність набагато нижча за номінальну, можливо, термін служби акумулятора IMPRES 2 або IMPRES добігає кінця. Однак акумулятор IMPRES 2 або IMPRES залишається придатним до використання. За певних обставин доречним буде віддати такий акумулятор тому, кому не потрібен акумулятор великої ємності для виконання завдань протягом своєї зміни.



Акумулятор APX NEXT XN оснащено функцією виявлення високої температури, яку визначає зарядний пристрій IMPRES 2 з програмним забезпеченням версії 2.05 або новішої. Коли цю функцію ввімкнено, після завершення заряджання акумулятора, який піддавався тривалому впливу надзвичайно високої температури, світлодіод стану по черзі блиматиме червоним і зеленим. На зарядному пристрої відобразатиметься таке:

REPLACE BATTERY  
EXPOSED OVERTEMP

Цей акумулятор рекомендується вилучити з експлуатації.

## Заряджання акумуляторів або радіостанцій разом з акумуляторами

Акумулятори найефективніше заряджаються за кімнатної температури. Багатомісні зарядні пристрої IMPRES 2 здатні заряджати акумулятори окремо або акумулятори, приєднані до радіостанції.

1. Установіть зарядний пристрій на рівну поверхню.
2. Вставте вилку шнура живлення до упору в роз'єм змінного струму в задній частині зарядного пристрою.
3. Підключіть шнур живлення до розетки з відповідними характеристиками.
4. Після підключення світлодіоди біля кожного гнізда засвітяться **зеленим** на 1 секунду, а на дисплеї з'явиться повідомлення `IMPRES 2 CHARGER`. Якщо індикатор стану заряджання не блимає та на дисплеї не відображаються повідомлення, перевірте підключення шнура живлення.
5. Вставте акумулятор окремо або радіостанцію з акумулятором у вільне гніздо.

**Примітка.** Коли виймаєте радіостанцію з гнізда або вставляєте її в гніздо, тримайте її за корпус. Не тягніть радіостанцію за антену.

6. Якщо радіостанцію або акумулятор вставлено в гніздо правильно, індикатор поряд із гніздом відобразить стан заряджання. На відповідному дисплеї з'явиться додаткова інформація. На моделях з одним дисплеєм на дисплеї відображається інформація лише щодо гнізда № 1.
7. Коли індикатор стану заряджання почне **постійно світитися зеленим**, це значить, що акумулятор готовий до використання.
8. Радіостанцію можна вмикати, тільки коли модуль передачі даних відокремлений від ПК. В іншому випадку вимкніть пристрій або радіостанцію.



Рис. 2: Заряджання радіостанції з акумулятором



Рис. 3: Заряджання акумулятора окремо від радіостанції

## Заряджання USB-пристроїв

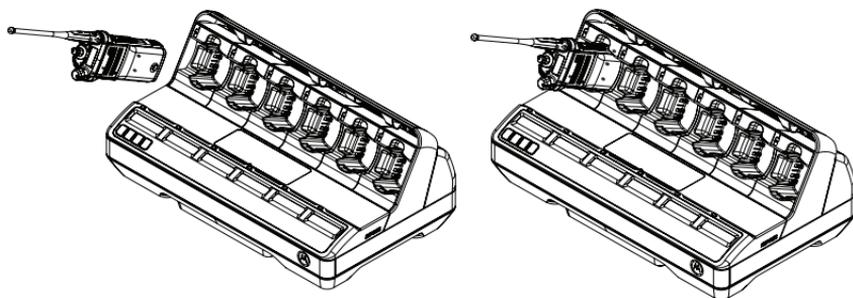
У деяких багатомісних зарядних пристроях IMPRES 2 модулі обміну даними оснащені гніздами USB типу A для заряджання USB-пристроїв. USB-пристрої найефективніше заряджаються за кімнатної температури.

1. Установіть адаптивний зарядний пристрій IMPRES 2 на рівну поверхню.
2. Вставте вилку шнура живлення до упору в роз'єм змінного струму в задній частині зарядного пристрою.
3. Підключіть шнур живлення до розетки з відповідними характеристиками.
4. Після підключення світлодіоди біля кожного гнізда засвітяться **зеленим** на 1 секунду, а на дисплеї з'явиться повідомлення IMPRES 2 CHARGER. Якщо індикатори стану не блимають і на дисплеї не відображаються повідомлення, перевірте підключення шнура живлення.
5. USB-пристрій може мати один роз'єм Micro-AB для заряджання. Використовуйте стандартний USB-кабель довжиною не більше 1 м із роз'ємом A на одному кінці та сумісним із пристроєм роз'ємом – на іншому (зазвичай Micro-B або Micro-AB).
6. Роз'єм A USB-кабелю слід правильно орієнтувати для підключення до гнізда типу A на модулі обміну даними. Вставте роз'єм у відповідне гніздо.
7. Роз'єм Micro-B USB-кабелю слід правильно орієнтувати для підключення до гнізда Micro-AB на USB-пристрої. Вставте роз'єм у відповідне гніздо.
8. Якщо пристрої з'єднано правильно, на USB-пристрої відобразатиметься стан заряджання. Більше інформації можна знайти в посібнику користувача USB-пристрою.

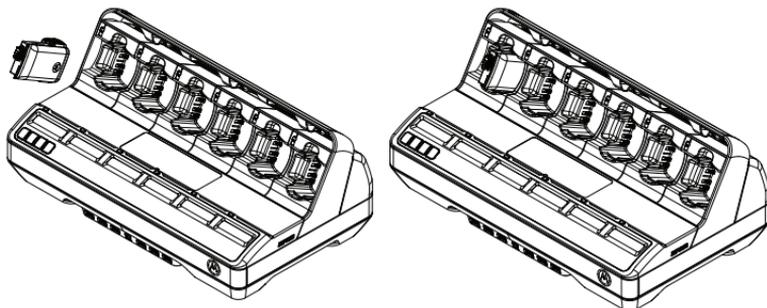
## Індикація під час заряджання

Табл. 6: Індикація під час заряджання акумуляторів IMPRES 2 або IMPRES – калібрування не потрібне

Стан	Дисплей поряд із гніздом	Світлодіодний індикатор
Зарядний пристрій підключено до джерела живлення	IMPRES 2 CHARGER	Зелений протягом приблизно 1 секунди 
Виявлено акумулятор	IMPRES 2 BATTERY АБО IMPRES BATTERY	Постійний червоний 
Швидке заряджання	RAPID CHARGE XXXXXmAh yyy%Pt1	Постійний червоний 
Заряджено на 90 % або більше	TRICKLE CHARGE xxxxxmAh yyy%Pt1	Блимаючий зелений 
Заряджено на 95 % або більше	CHARGE COMPLETE xxxxxmAh yyy%Pt1	Постійний зелений 
Помилка	ПОПЕРЕДЖЕННЯ. NOT CHARGEABLE REMOVE & REINSERT	Блимаючий червоний 
Режим очікування • Акумулятор очікує на швидке заряджання. • Акумулятор перегрівся чи надто холодний, або рівень напруги занижений. • Зарядний пристрій перегрівся.	ПОПЕРЕДЖЕННЯ. HOT BATTERY WAITING TO CHARGE АБО COLD BATTERY WAITING TO CHARGE АБО VERY LOW BATTERY WAITING TO CHARGE АБО HOT CHARGER WAITING TO CHARGE	Блимаючий жовтий 

### Примітка.

- Повідомлення Hot Charger (Висока температура зарядного пристрою) впроваджено у версії програмного забезпечення V1.05.
- Відсоткові показники стану зарядного пристрою, які означають співвідношення потенційної та номінальної ємності, впроваджено у версії програмного забезпечення V1.11.01.

**Табл. 7:** Індикація заряджання під час калібрування акумуляторів IMPRES 2 або IMPRES – функцію калібрування ввімкнено

Стан	Дисплей поряд із гніздом	Світлодіодний індикатор
Зарядний пристрій підключено до джерела живлення	IMPRES 2 CHARGER	Зелений протягом приблизно 1 секунди 
Виявлено акумулятор	IMPRES 2 BATTERY АБО IMPRES BATTERY	Постійний жовтий 
Розрядження акумулятора	CAL DISCHARGE xxxxx0mAh yyy%P t.1	Постійний жовтий 
Швидке заряджання	CAL RAPID CHARGE xxxxx0mAh yyy%P t.1	Постійний червоний 
Заряджено на 90 % або більше	CAL TRICKLE CHARGE xxxxx0mAh yyy%P t.1	Блимаючий зелений 
Заряджено на 95 % або більше	CHARGE COMPLETE xxxxx0mAh yyy%P t.1	Калібрування акумулятора успішно завершено: постійний зелений 
	REPLACE BATTERY EXPOSED OVERTEMP	Калібрування акумулятора успішно завершено, але, можливо, термін служби закінчується (акумулятор придатний до використання): блимаючий червоний/ зелений 
		Калібрування акумулятора успішно завершено, але акумулятор піддавався тривалому впливу надмірної температури (радімо вилучити його з експлуатації): блимаючий червоний/зелений ПРИМІТКА. Стосується лише акумулятора APX NEXT XN! 

**Табл. 7:** Індикація заряджання під час калібрування акумуляторів IMPRES 2 або IMPRES – функцію калібрування ввімкнено (продовження)

Стан	Дисплей поряд із гніздом	Світлодіодний індикатор
Помилка	ПОПЕРЕДЖЕННЯ. NOT CHARGEABLE REMOVE & REINSERT	Блимаючий червоний 
Режим очікування <ul style="list-style-type: none"> <li>• Акумулятор очікує на швидке заряджання.</li> <li>• Акумулятор перегрівся чи надто холодний, або рівень напруги занижений.</li> <li>• Зарядний пристрій перегрівся.</li> </ul>	ПОПЕРЕДЖЕННЯ. HOT BATTERY WAITING TO CAL АБО COLD BATTERY WAITING TO CAL АБО VERY LOW BATTERY WAITING TO CHARGE АБО HOT CHARGER WAITING TO CAL	Блимаючий жовтий 

**Табл. 8:** Індикація заряджання під час калібрування акумуляторів IMPRES 2 або IMPRES – калібрування скасовано, а потім знову ввімкнено

Стан	Дисплей зарядного пристрою	Світлодіодний індикатор
Зарядний пристрій підключено до джерела живлення	IMPRES 2 CHARGER	Зелений протягом приблизно 1 секунди 
Виявлено акумулятор	IMPRES 2 BATTERY АБО IMPRES BATTERY	Акумулятор потребує калібрування, однак цю функцію вимкнено на зарядному пристрої: навперемінно жовтий і зелений впродовж 4 секунд 
Запит на калібрування акумулятора IMPRES • Калібрування вимкнено на зарядному пристрої. • Триває заряджання акумулятора	ПОПЕРЕДЖЕННЯ. ENABLE BATTERY CALIBRATION? • Натисніть «ОК», щоб розпочати калібрування • Ігноруйте, щоб продовжити звичайне заряджання (повідомлення зникне за 1 хвилину)	Постійний червоний 
Розряджання акумулятора • Натиснуто «ОК»	CAL DISCHARGE xxxxxmAh yyy%P+t1	Постійний жовтий 
Швидке заряджання	CAL RAPID CHARGE xxxxxmAh yyy%P+t1	Постійний червоний 
Заряджено на 90 % або більше	CAL TRICKLE CHRG xxxxxmAh yyy%P+t1	Блимаючий зелений 

**Табл. 8:** Індикація заряджання під час калібрування акумуляторів IMPRES 2 або IMPRES – калібрування скасовано, а потім знову ввімкнено (продовження)

Стан	Дисплей зарядного пристрою	Світлодіодний індикатор
Заряджено на 95 % або більше	CHARGE COMPLETE xxxxxmAh yyy%P+1	Калібрування акумулятора успішно завершено: постійний зелений 
	REPLACE BATTERY EXPOSED OVERTEMP	Калібрування акумулятора успішно завершено, але, можливо, термін служби закінчується (акумулятор придатний до використання): блимаючий червоний/зелений 
Помилка	ПОПЕРЕДЖЕННЯ. NOT CHARGEABLE REMOVE& REINSERT	Блимаючий червоний 
Режим очікування • Акумулятор очікує на швидке заряджання. • Акумулятор перегрівся чи надто холодний, або рівень напруги занизький. • Зарядний пристрій перегрівся.	ПОПЕРЕДЖЕННЯ. HOT BATTERY WAITING TO CAL АБО COLD BATTERY WAITING TO CAL АБО VERY LOW BATTERY WAITING TO CHARGE АБО HOT CHARGER WAITING TO CAL	Блимаючий жовтий 



**Табл. 9:** Індикація під час заряджання акумуляторів IMPRES 2 або IMPRES – потрібне калібрування, але цю функцію вимкнено

Стан	Дисплей зарядного пристрою	Світлодіодний індикатор
Зарядний пристрій підключено до джерела живлення	IMPRES 2 CHARGER	Зелений протягом приблизно 1 секунди 
Виявлено акумулятор	IMPRES 2 BATTERY АБО IMPRES BATTERY	Акумулятор потребує калібрування, однак цю функцію вимкнено на зарядному пристрої: навперемінно жовтий і зелений впродовж 4 секунд 
Запит на калібрування акумулятора IMPRES <ul style="list-style-type: none"><li>Калібрування вимкнено на зарядному пристрої.</li><li>Триває заряджання акумулятора.</li></ul>	ПОПЕРЕДЖЕННЯ. ENABLE BATTERY CALIBRATION? <ul style="list-style-type: none"><li>Натисніть «ОК», щоб розпочати калібрування.</li><li>Ігноруйте, щоб продовжити звичайне заряджання (повідомлення зникне за 1 хвилину).</li></ul>	Постійний червоний 
Швидке заряджання <ul style="list-style-type: none"><li>Час очікування для запиту калібрування сплинув.</li></ul>	RAPID CHARGE xxxxx@mAh yyy%P t1	Постійний червоний 
Заряджено на 90 % або більше	TRICKLE CHARGE xxxxx@mAh yyy%P t1	Блимаючий зелений 
Заряджено на 95 % або більше	CHARGE COMPLETE xxxxx@mAh yyy%P t1	Навперемінно жовтий і зелений 
Помилка	ПОПЕРЕДЖЕННЯ. NOT CHARGEABLE REMOVE& REINSERT	Блимаючий червоний 
Режим очікування <ul style="list-style-type: none"><li>Акумулятор очікує на швидке заряджання.</li><li>Акумулятор перегрівся чи надто холодний, або рівень напруги занизький.</li><li>Зарядний пристрій перегрівся.</li></ul>	ПОПЕРЕДЖЕННЯ. HOT BATTERY WAITING TO CHRGE АБО COLD BATTERY WAITING TO CHRGE АБО VERY LOW BATTERY WAITING TO CHRGE АБО HOT CHARGER WAITING TO CHRGE	Блимаючий жовтий 

**Табл. 10:** Індикація під час заряджання повністю заряджених акумуляторів IMPRES 2 або IMPRES – потрібне калібрування, але цю функцію вимкнено

Стан	Дисплей зарядного пристрою	Світлодіодний індикатор
Зарядний пристрій підключено до джерела живлення	IMPRES 2 CHARGER	Зелений протягом приблизно 1 секунди 
Виявлено акумулятор	IMPRES 2 BATTERY АБО IMPRES BATTERY	Акумулятор потребує калібрування, але був повністю заряджений протягом останніх 30 хвилин, а на зарядному пристрої було вимкнено функцією калібрування: навперемінно жовтий і зелений 
Помилка	ПОПЕРЕДЖЕННЯ. NOT CHARGEABLE REMOVE & REINSERT	Блимаючий червоний 
Режим очікування <ul style="list-style-type: none"> <li>• Акумулятор очікує на швидке заряджання.</li> <li>• Акумулятор перегрівся чи надто холодний, або рівень напруги занижений.</li> <li>• Зарядний пристрій перегрівся.</li> </ul>	ПОПЕРЕДЖЕННЯ. HOT BATTERY WAITING TO CHARGE АБО COLD BATTERY WAITING TO CHARGE АБО VERY LOW BATTERY WAITING TO CHARGE АБО HOT CHARGER WAITING TO CHARGE	Блимаючий жовтий 

## Інші акумулятори від Motorola Solutions

**Табл. 11:** Індикація під час заряджання інших акумуляторів Motorola Solutions

Стан	Дисплей зарядного пристрою	Світлодіодний індикатор
Зарядний пристрій підключено до джерела живлення	IMPRES 2 CHARGER	Зелений протягом приблизно 1 секунди 
Виявлено акумулятор	MOTOROLA SOLUTIONS BATTERY	Постійний червоний 
Швидке заряджання	RAPID CHARGE	Постійний червоний 
Заряджено на 90 % або більше	TRICKLE CHARGE	Блимаючий зелений 
Заряджено на 95 % або більше	CHARGE COMPLETE	Постійний зелений 
Помилка	ПОПЕРЕДЖЕННЯ. HOT CHARGEABLE REMOVE & REINSERT	Блимаючий червоний 
Режим очікування <ul style="list-style-type: none"> <li>Акумулятор очікує на швидке заряджання.</li> <li>Акумулятор перегрівся чи надто холодний, або рівень напруги занижений.</li> <li>Зарядний пристрій перегрівся.</li> </ul>	ПОПЕРЕДЖЕННЯ. HOT BATTERY WAITING TO CHARGE АБО COLD BATTERY WAITING TO CHARGE АБО VERY LOW BATTERY WAITING TO CHARGE АБО HOT CHARGER WAITING TO CHARGE	Блимаючий жовтий 

## Невідомий тип акумулятора

Деякі типи акумуляторів сторонніх виробників можуть не розпізнаватися зарядним пристроєм. Формат параметрів заряджання таких акумуляторів не розпізнається зарядним пристроєм. Якщо йому вдається розпізнати невідомий акумулятор, процес заряджання супроводжуватиметься індикацією, зазначеною в Табл. 12.

**Табл. 12:** Індикація під час заряджання невідомих типів акумуляторів

Стан	Дисплей зарядного пристрою	Світлодіодний індикатор
Зарядний пристрій підключено до джерела живлення	IMPRES 2 CHARGER	Зелений протягом приблизно 1 секунди 
Виявлено акумулятор	UNKNOWN BATTERY	Постійний червоний 
Швидке заряджання	RAPID CHARGE	Постійний червоний 
Майже повний заряд • Ємність акумулятора не відома	TRICKLE CHARGE	Блимаючий зелений 
Заряджено • Ємність акумулятора не відома	CHARGE COMPLETE	Постійний зелений 
Помилка	ПОПЕРЕДЖЕННЯ. NOT CHARGEABLE REMOVE & REINSERT	Блимаючий червоний 
Режим очікування • Акумулятор очікує на швидке заряджання. • Акумулятор перегрівся чи надто холодний, або рівень напруги занизький. • Зарядний пристрій перегрівся.	ПОПЕРЕДЖЕННЯ. HOT BATTERY WAITING TO CHARGE АБО COLD BATTERY WAITING TO CHARGE АБО VERY LOW BATTERY WAITING TO CHARGE АБО HOT CHARGER WAITING TO CHARGE	Блимаючий жовтий 

## Тривале зберігання акумуляторів IMPRES 2 або IMPRES

За допомогою багатомісного зарядного пристрою IMPRES 2 оригінальні окремі акумулятори IMPRES 2 або IMPRES (літій-іонні або нікелеві) компанії Motorola Solutions можна підготувати до тривалого зберігання в місці з відповідними умовами. Інші типи акумуляторів спричинятимуть помилку. Якщо акумулятор IMPRES 2 підтримує режим сну (Sleep mode), то після завершення заряджання для тривалого зберігання зарядний пристрій переведе такий акумулятор до цього режиму.

Для тривалого зберігання готуйте тільки акумулятори типів IMPRES 2 або IMPRES. Перед установленням у зарядний пристрій від'єднайте акумулятор від радіостанції.

НЕ МОЖНА зберігати від'єднаний акумулятор у зарядному пристрої. Коли підготовку до тривалого зберігання завершено, негайно вийміть акумулятор із зарядного пристрою.

Налаштування для тривалого зберігання мають пріоритет перед налаштуваннями калібрування/відновлення. Літій-іонні акумулятори, підготовлені до тривалого зберігання, можуть не відповідати правилам авіаперевезення вантажів.

**Табл. 13:** Індикація під час підготовки до тривалого зберігання акумуляторів IMPRES 2 або IMPRES – акумулятор має пройти калібрування

Стан	Дисплей зарядного пристрою	Світлодіодний індикатор
Зарядний пристрій підключено до джерела живлення	IMPRES 2 CHARGER	Зелений протягом приблизно 1 секунди 
Виявлено акумулятор	IMPRES 2 BATTERY АБО IMPRES BATTERY	Акумулятор потребує калібрування: навперемінно жовтий і зелений впродовж 4 секунд 
Розрядження акумулятора	STORAGE DISCHARGE xxxx% Rated Cap	Постійний жовтий 
Швидке заряджання	STORAGE CHARGE xxx% Rated Cap	Постійний червоний 

**Табл. 13:** Індикація під час підготовки до тривалого зберігання акумуляторів IMPRES 2 або IMPRES – акумулятор має пройти калібрування (продовження)

Стан	Дисплей зарядного пристрою	Світлодіодний індикатор
Підготований до тривалого зберігання	LONGTERM STORAGE xxx% Rated Cap	Навперемінно жовтий і зелений 
Помилка <ul style="list-style-type: none"> <li>Не забезпечується належний електричний контакт між акумулятором і зарядним пристроєм.</li> <li>Акумулятор не належить до типу IMPRES 2 або IMPRES.</li> <li>Невідома обставина не дає змоги розрядити акумулятор.</li> <li>Зарядження було завершено до того, як могло бути досягнуто цільове значення для тривалого зберігання.</li> <li>Гніздо зарядного пристрою має нестандартний тип.</li> </ul>	ПОПЕРЕДЖЕННЯ. NOT CHARGEABLE REMOVE & REINSERT АБО WRONG BATT TYPE CANNOT LT STORE АБО CANNOT DISCHARGE FOR LT STORAGE АБО STORE INCOMPLETE Low Capacity:yy% АБО RADIO POCKET CANNOT LT STORE АБО CHARGING POCKET CANNOT LT STORE	Блимаючий червоний 
Режим очікування <ul style="list-style-type: none"> <li>Акумулятор очікує на швидке зарядження.</li> <li>Акумулятор перегрівся чи надто холодний, або рівень напруги занижений.</li> <li>Зарядний пристрій перегрівся.</li> </ul>	ПОПЕРЕДЖЕННЯ. HOT BATTERY WAITING TO CHARGE АБО COLD BATTERY WAITING TO CHARGE АБО VERY LOW BATTERY WAITING TO CHARGE АБО HOT CHARGER WAITING TO CHARGE	Блимаючий жовтий 

Українська

**Примітка.**

- У версії програмного забезпечення V1.05 впроваджено такі повідомлення:
  - «Cannot Discharge, for LT Storage» (Позрядження для тривалого зберігання неможливе)
  - «Store Incomplete, Low Capacity:yy%» (Підготовку до зберігання не завершено, низька ємність: yy%)
  - «Hot Charger, Waiting to Chрге» (Висока температура зарядного пристрою, очікування зарядження)

- У версії програмного забезпечення V1.11.01 впроваджено такі повідомлення:
  - «Wrong Batt Type, Cannot LT Store» (Неправильний тип акумулятора, підготовка до тривалого зберігання неможлива)
  - «Radio Pocket, Cannot LT Store» (Гніздо для радіостанції, підготовка до тривалого зберігання неможлива)
  - «Charging Pocket, Cannot LT Store» (Зарядне гніздо, підготовка до тривалого зберігання неможлива)

**Табл. 14:** Індикація під час підготовки до тривалого зберігання акумуляторів IMPRES 2 або IMPRES – калібрований акумулятор, має бути зарядженим до налаштованого рівня

Стан	Дисплей зарядного пристрою	Світлодіодний індикатор
Зарядний пристрій підключено до джерела живлення	IMPRES 2 CHARGER	Зелений протягом приблизно 1 секунди 
Виявлено акумулятор	IMPRES 2 BATTERY АБО IMPRES BATTERY	Постійний червоний 
Швидке заряджання	STORAGE CHARGE xxx% Rated Cap	Постійний червоний 
Підготований до тривалого зберігання	LONGTERM STORAGE xxx% Rated Cap	Постійний зелений 
Помилка <ul style="list-style-type: none"> <li>• Не забезпечується належний електричний контакт між акумулятором і зарядним пристроєм.</li> <li>• Акумулятор не належить до типу IMPRES 2 або IMPRES.</li> <li>• Невідома обставина не дає змоги розрядити акумулятор.</li> <li>• Заряджання було завершено до того, як могло бути досягнуто цільове значення для тривалого зберігання.</li> <li>• Гніздо зарядного пристрою має нестандартний тип.</li> </ul>	ПОПЕРЕДЖЕННЯ. NOT CHARGEABLE REMOVE& REINSERT АБО WRONG BATT TYPE CANNOT LT STORE АБО CANNOT DISCHARGE FOR LT STORAGE АБО STORE INCOMPLETE Low Capacity:yy% АБО RADIO POCKET CANNOT LT STORE АБО CHARGING POCKET CANNOT LT STORE	Блимаючий червоний 

**Табл. 14:** Індикація під час підготовки до тривалого зберігання акумуляторів IMPRES 2 або IMPRES – калібрований акумулятор, має бути зарядженим до налаштованого рівня (продовження)

Стан	Дисплей зарядного пристрою	Світлодіодний індикатор
<p>Режим очікування</p> <ul style="list-style-type: none"> <li>• Акумулятор очікує на швидке зарядження.</li> <li>• Акумулятор перегрівся чи надто холодний, або рівень напруги занижений.</li> <li>• Зарядний пристрій перегрівся.</li> </ul>	<p>ПОПЕРЕДЖЕННЯ.</p> <p>HOT BATTERY WAITING TO CHARGE АБО</p> <p>COLD BATTERY WAITING TO CHARGE АБО</p> <p>VERY LOW BATTERY WAITING TO CHARGE АБО</p> <p>HOT CHARGER WAITING TO CHARGE</p>	<p>Блимаючий жовтий </p>

**Табл. 15:** Індикація під час підготовки до тривалого зберігання акумуляторів IMPRES 2 або IMPRES – калібрований акумулятор, має бути розрядженим до налаштованого рівня

Стан	Дисплей зарядного пристрою	Світлодіодний індикатор
Зарядний пристрій підключено до джерела живлення	IMPRES 2 CHARGER	Зелений протягом приблизно 1 секунди 
Виявлено акумулятор	IMPRES 2 BATTERY АБО IMPRES BATTERY	Постійний жовтий 
Розрядження акумулятора	STORAGE DISCHARGE xxx% Rated Cap	Постійний жовтий 
Підготований до тривалого зберігання	LONGTERM STORAGE xxx% Rated Cap	Постійний зелений 



**Табл. 15:** Індикація під час підготовки до тривалого зберігання акумуляторів IMPRES 2 або IMPRES – калібрований акумулятор, має бути розрядженим до налаштованого рівня (продовження)

Стан	Дисплей зарядного пристрою	Світлодіодний індикатор
<p>Помилка</p> <ul style="list-style-type: none"> <li>Не забезпечується належний електричний контакт між акумулятором і зарядним пристроєм.</li> <li>Акумулятор не належить до типу IMPRES 2 або IMPRES.</li> <li>Невідома обставина не дає змоги розрядити акумулятор.</li> <li>Зарядження було завершено до того, як могло бути досягнуто цільове значення для тривалого зберігання.</li> <li>Гніздо зарядного пристрою має нестандартний тип.</li> </ul>	<p>ПОПЕРЕДЖЕННЯ.  NOT CHARGEABLE  REMOVE&amp; REINSERT  АБО  WRONG BATT TYPE  CANNOT LT STORE  АБО  CANNOT DISCHARGE  FOR LT STORAGE  АБО  STORE INCOMPLETE  Low Capacity:yy%  АБО  RADIO POCKET  CANNOT LT STORE  АБО  CHARGING POCKET  CANNOT LT STORE</p>	<p>Блимаючий червоний </p>
<p>Режим очікування</p> <ul style="list-style-type: none"> <li>Акумулятор очікує на швидке зарядження.</li> <li>Акумулятор перегрівся чи надто холодний, або рівень напруги занижений.</li> <li>Зарядний пристрій перегрівся.</li> </ul>	<p>ПОПЕРЕДЖЕННЯ.  HOT BATTERY  WAITING TO CHARGE  АБО  COLD BATTERY  WAITING TO CHARGE  АБО  VERY LOW BATTERY  WAITING TO CHARGE  АБО  HOT CHARGER  WAITING TO CHARGE</p>	<p>Блимаючий жовтий </p>

## Підготовка літій-іонних акумуляторів до транспортування

За допомогою багатомісного зарядного пристрою IMPRES 2 окремі акумулятори типів IMPRES 2, IMPRES або інші оригінальні літій-іонні акумулятори Motorola Solutions можна підготувати до транспортування відповідно до правил авіаперевезення вантажів. Інші типи акумуляторів спричинятимуть помилку. Якщо літій-іонний акумулятор IMPRES 2 підтримує режим сну (Sleep mode), то після завершення зарядження літій-іонного акумулятора для транспортування зарядний пристрій переведе такий акумулятор у цей режим.

Підготовка до транспортування літій-іонних акумуляторів від Motorola Solutions здійснюється тільки для акумуляторів окремо. Перед установленням у зарядний пристрій від'єднайте акумулятор від радіостанції.

НЕ МОЖНА зберігати від'єднаний акумулятор у зарядному пристрої. Коли підготовку до транспортування літій-іонного акумулятора завершено, негайно вийміть акумулятор із зарядного пристрою.

Налаштування для транспортування літієвих акумуляторів мають пріоритет перед налаштуваннями калібрування/відновлення.

## Акумулятор IMPRES 2 або IMPRES

**Табл. 16:** Індикація стану підготовки літій-іонного акумулятора до транспортування – акумулятор IMPRES 2 або IMPRES має пройти калібрування

Стан	Дисплей зарядного пристрою	Світлодіодний індикатор
Зарядний пристрій підключено до джерела живлення	IMPRES 2 CHARGER	Зелений протягом приблизно 1 секунди 
Виявлено акумулятор	IMPRES 2 BATTERY АБО IMPRES BATTERY	Акумулятор потребує калібрування: наперемінно жовтий і зелений  впродовж 4 секунд
Розрядження акумулятора	SHIP LI DISCHARGE xxx% Rated Cap	Постійний жовтий 
Швидке заряджання	SHIP LI CHARGE xxx% Rated Cap	Постійний червоний 
Підготовку літій-іонного акумулятора до транспортування завершено	LI READY TO SHIP xxx% Rated Cap	Наперемінно жовтий і зелений 
Помилка <ul style="list-style-type: none"> <li>Не забезпечується належний електричний контакт між акумулятором і зарядним пристроєм.</li> <li>Невідомий тип акумулятора або нікелевий акумулятор.</li> <li>Невідома обставина не дає змоги розрядити акумулятор.</li> <li>Заряджання було завершено до того, як було досягнуто цільове значення для підготовки до транспортування.</li> <li>Гніздо зарядного пристрою має нестандартний тип.</li> </ul>	ПОПЕРЕДЖЕННЯ. NOT CHARGEABLE REMOVE& REINSERT АБО WRONG BATT TYPE CANNOT SHIP LI АБО CANNOT DISCHARGE FOR LI SHIPMENT АБО SHIP INCOMPLETE Low Capacity:yy% АБО RADIO POCKET CANNOT SHIP LI АБО CHARGING POCKET CANNOT SHIP LI	Блимаючий червоний 

**Табл. 16:** Індикація стану підготовки літій-іонного акумулятора до транспортування – акумулятор IMPRES 2 або IMPRES має пройти калібрування (продовження)

Стан	Дисплей зарядного пристрою	Світлодіодний індикатор
<p>Режим очікування</p> <ul style="list-style-type: none"> <li>• Акумулятор очікує на швидке заряджання.</li> <li>• Акумулятор перегрівся чи надто холодний, або рівень напруги занижений.</li> <li>• Зарядний пристрій перегрівся.</li> </ul>	<p>ПОПЕРЕДЖЕННЯ.</p> <p>HOT BATTERY WAITING TO CHARGE АБО</p> <p>COLD BATTERY WAITING TO CHARGE АБО</p> <p>VERY LOW BATTERY WAITING TO CHARGE АБО</p> <p>HOT CHARGER WAITING TO CHARGE</p>	<p>Блимаючий жовтий </p>

### Примітка.

- У версії програмного забезпечення V1.05 впроваджено такі повідомлення:
  - «Ship Li Discharge, xxx% Rated Capacity» (Розрядження літійового акумулятора під час підготовки до транспортування, xxx% від ном. ємності)
  - «Ship Li Charge, xxx% Rated Capacity» (Зарядження літійового акумулятора під час підготовки до транспортування, xxx% від ном. ємності)
  - «Li Ready to Ship, xxx% Rated Capacity» (Літійовий акумулятор готовий до транспортування, xxx% від ном. ємності)
  - «Cannot Discharge, for Li Shipment» (Розрядження літійового акумулятора для транспортування неможливе)
  - «Ship Incomplete, Low Capacity:yy%» (Підготовку до транспортування не завершено, низька ємність: yy%)
- У версії програмного забезпечення V1.11.01 впроваджено такі повідомлення:
  - «Wrong Batt Type, Cannot Ship Li» (Неправильний тип акумулятора, підготовка до транспортування неможлива)

- «Radio Pocket, Cannot Ship Li» (Гніздо для радіостанції, підготовка до транспортування неможлива)
- «Charging Pocket, Cannot Ship Li» (Зарядне гніздо, підготовка до транспортування неможлива)

**Табл. 17:** Індикація стану підготовки літій-іонного акумулятора до транспортування – калібрований акумулятор IMPRES 2 або IMPRES, має бути зарядженим

Стан	Дисплей зарядного пристрою	Світлодіодний індикатор
Зарядний пристрій підключено до джерела живлення	IMPRES 2 CHARGER	Зелений протягом приблизно 1 секунди 
Виявлено акумулятор	IMPRES 2 BATTERY АБО IMPRES BATTERY	Постійний червоний 
Швидке заряджання	SHIP LI CHARGE xxx% Rated Cap	Постійний червоний 
Підготовку літій-іонного акумулятора до транспортування завершено	LI READY TO SHIP xxx% Rated Cap	Постійний зелений 
Помилка <ul style="list-style-type: none"> <li>• Не забезпечується належний електричний контакт між акумулятором і зарядним пристроєм.</li> <li>• Невідомий тип акумулятора або нікелевий акумулятор</li> <li>• Невідома обставина не дає змоги розрядити акумулятор.</li> <li>• Заряджання було завершено до того, як було досягнуто цільове значення для підготовки до транспортування.</li> <li>• Гніздо зарядного пристрою має нестандартний тип.</li> </ul>	ПОПЕРЕДЖЕННЯ. NOT CHARGEABLE REMOVE& REINSERT АБО WRONG BATT TYPE CANNOT SHIP LI АБО CANNOT DISCHARGE FOR LI SHIPMENT АБО SHIP INCOMPLETE Low Capacity:yy% АБО RADIO POCKET CANNOT SHIP LI АБО CHARGING POCKET CANNOT SHIP LI	Блимаючий червоний 

**Табл. 17:** Індикація стану підготовки літій-іонного акумулятора до транспортування – калібрований акумулятор IMPRES 2 або IMPRES, має бути зарядженим (продовження)

Стан	Дисплей зарядного пристрою	Світлодіодний індикатор
<p>Режим очікування</p> <ul style="list-style-type: none"> <li>• Акумулятор очікує на швидке заряджання.</li> <li>• Акумулятор перегрівся чи надто холодний, або рівень напруги занижений.</li> <li>• Зарядний пристрій перегрівся.</li> </ul>	<p>ПОПЕРЕДЖЕННЯ.</p> <p>HOT BATTERY WAITING TO CHARGE АБО</p> <p>COLD BATTERY WAITING TO CHARGE АБО</p> <p>VERY LOW BATTERY WAITING TO CHARGE АБО</p> <p>HOT CHARGER WAITING TO CHARGE</p>	<p>Блимаючий жовтий </p>

**Табл. 18:** Індикація стану підготовки літій-іонного акумулятора до транспортування – калібрований акумулятор IMPRES 2 або IMPRES, має бути розрядженим

Стан	Дисплей зарядного пристрою	Світлодіодний індикатор
Зарядний пристрій підключено до джерела живлення	IMPRES 2 CHARGER	Зелений протягом приблизно 1 секунди 
Виявлено акумулятор	IMPRES 2 BATTERY АБО IMPRES BATTERY	Постійний жовтий 
Розрядження акумулятора	SHIP LI DISCHARGE xxx% Rated Cap	Постійний жовтий 
Підготовку літій-іонного акумулятора до транспортування завершено	LI READY TO SHIP xxx% Rated Cap	Постійний зелений 

**Табл. 18:** Індикація стану підготовки літій-іонного акумулятора до транспортування – калібрований акумулятор IMPRES 2 або IMPRES, має бути розрядженим (продовження)

Стан	Дисплей зарядного пристрою	Світлодіодний індикатор
<p>Помилка</p> <ul style="list-style-type: none"> <li>Не забезпечується належний електричний контакт між акумулятором і зарядним пристроєм.</li> <li>Невідомий тип акумулятора або нікелевий акумулятор</li> <li>Невідома обставина не дає змоги розрядити акумулятор.</li> <li>Заряджання було завершено до того, як було досягнуто цільове значення для підготовки до транспортування.</li> <li>Гніздо зарядного пристрою має нестандартний тип.</li> </ul>	<p>ПОПЕРЕДЖЕННЯ.  NOT CHARGEABLE  REMOVE&amp; REINSERT  АБО  WRONG BATT TYPE  CANNOT SHIP LI  АБО  CANNOT DISCHARGE  FOR LI SHIPMENT  АБО  SHIP INCOMPLETE  Low Capacity:yy%  АБО  RADIO POCKET  CANNOT SHIP LI  АБО  CHARGING POCKET  CANNOT SHIP LI</p>	<p>Блимаючий червоний</p> 
<p>Режим очікування</p> <ul style="list-style-type: none"> <li>Акумулятор очікує на швидке заряджання.</li> <li>Акумулятор перегрівся чи надто холодний, або рівень напруги занижкий.</li> <li>Зарядний пристрій перегрівся.</li> </ul>	<p>ПОПЕРЕДЖЕННЯ.  HOT BATTERY  WAITING TO CHRGE  АБО  COLD BATTERY  WAITING TO CHRGE  АБО  VERY LOW BATTERY  WAITING TO CHRGE  АБО  HOT CHARGER  WAITING TO CHRGE</p>	<p>Блимаючий жовтий</p> 

## Інші акумулятори від Motorola Solutions

**Табл. 19:** Індикація стану підготовки літій-іонного акумулятора до транспортування – інші типи акумуляторів Motorola Solutions

Стан	Дисплей зарядного пристрою	Світлодіодний індикатор
Зарядний пристрій підключено до джерела живлення	IMPRES 2 CHARGER	Зелений протягом приблизно 1 секунди 
Виявлено акумулятор	MOTOROLA SOLUTIONS BATTERY	Постійний жовтий 
Розрядження акумулятора	SHIP LI DISCHARGE xxx% Rated Cap	Постійний жовтий 
Швидке зарядження	SHIP LI CHARGE xxx% Rated Cap	Постійний червоний 
Підготовку літій-іонного акумулятора до транспортування завершено	LI READY TO SHIP xxx% Rated Cap	Постійний зелений 
Помилка <ul style="list-style-type: none"> <li>Не забезпечується належний електричний контакт між акумулятором і зарядним пристроєм.</li> <li>Невідомий тип акумулятора або нікелевий акумулятор</li> <li>Невідома обставина не дає змоги розрядити акумулятор.</li> <li>Зарядження було завершено до того, як було досягнуто цільове значення для підготовки до транспортування.</li> <li>Гніздо зарядного пристрою має нестандартний тип.</li> </ul>	ПОПЕРЕДЖЕННЯ. NOT CHARGEABLE REMOVE& REINSERT АБО WRONG BATT TYPE CANNOT SHIP LI АБО CANNOT DISCHARGE FOR LI SHIPMENT АБО SHIP INCOMPLETE Low Capacity:yy% АБО RADIO POCKET CANNOT SHIP LI АБО CHARGING POCKET CANNOT SHIP LI	Блимаючий червоний 
Режим очікування <ul style="list-style-type: none"> <li>Акумулятор очікує на швидке зарядження.</li> <li>Акумулятор перегрівся чи надто холодний, або рівень напруги занизький.</li> <li>Зарядний пристрій перегрівся.</li> </ul>	ПОПЕРЕДЖЕННЯ. HOT BATTERY WAITING TO CHARGE АБО COLD BATTERY WAITING TO CHARGE АБО VERY LOW BATTERY WAITING TO CHARGE АБО HOT CHARGER WAITING TO CHARGE	Блимаючий жовтий 



## Меню налаштувань зарядного пристрою



Перш ніж переходити в режим налаштування зарядного пристрою, звільніть усі зарядні гнізда.

Клавіатуру зарядного пристрою розташовано під дисплеєм гнізда № 1.

Щоб відкрити меню налаштувань зарядного пристрою, одночасно натисніть стрілку вліво та стрілку вправо й утримуйте їх довше вибраної тривалості входу (за замовчуванням це 3 секунди).

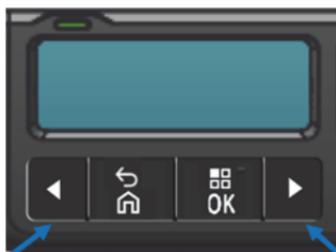

Стрілка вліво

Стрілка вправо

**Рис. 4:** Кнопки меню дисплея для входу в режим налаштування

### Головне меню

Після входу в режим налаштування зарядного пристрою відображається таке повідомлення:

```
Press OK to entr  
SETUP MENU
```

Після натискання кнопки «OK» на дисплеї з'явиться меню налаштувань.



Рис. 5: Меню налаштувань зарядного пристрою

## Навігація в меню налаштувань зарядного пристрою

Навігація в усіх пунктах меню налаштувань здійснюється таким чином:

- Натисніть стрілку вправо, щоб переглянути по черзі всі пункти меню.
- Натисніть стрілку вліво, щоб переглянути всі пункти меню у зворотному порядку.
- Натисніть OK, щоб увійти до вибраного меню або вибрати потрібний параметр.

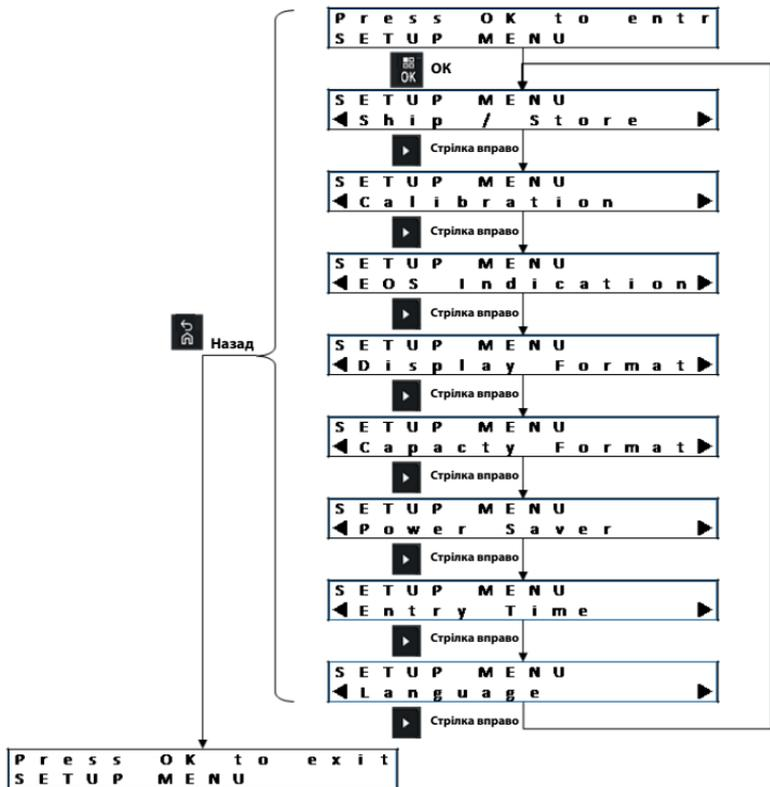
**Примітка.** Вибрані параметри позначено прапорцями.  
Функцію впроваджено у версії V1.11.01: натисніть «ОК» для відображення наступного гнізда на дисплеї гнізда № 1.

- Натисніть «Назад», щоб вийти з вибраного меню, а потім – ОК, щоб підтвердити вихід.

Якщо впродовж 10 хвилин не натиснуто жодної кнопки, зарядний пристрій самостійно вийде з режиму налаштування й повернеться до звичайного відображення повідомлень.

Вибрані налаштування зарядного пристрою зберігаються в енергонезалежній пам'яті. Вони не залежать від вимкнення й увімкнення живлення зарядного пристрою.

## **Меню транспортування або зберігання**

Меню «Ship / Storage» має чотири пункти:

- Disabled (Вимкнено)
- Ship Lithium-ion (Транспортування літій-іонного акумулятора)
- Long-Term Storage (Тривале зберігання)
- Long-Term Storage at 75% of Rated Capacity (Тривале зберігання із 75 % від номінальної ємності)

Налаштування «Ship Lithium-ion», «Long-Term Storage» та «Long-Term Storage at 75% of Rated Capacity» мають пріоритет перед налаштуваннями калібрування.



Рис. 6: Меню транспортування або зберігання

## Ship Lithium (Транспортування літій-іонного акумулятора)

Режим транспортування літій-іонного акумулятора задає стан заряду для літій-іонного акумулятора Motorola Solutions на низьке значення, дозволене для масового транспортування: приблизно 25 % від номінальної ємності.

Деякі акумулятори Motorola Solutions можуть бути повністю розрядженими перед зарядженням до обмеженого рівня, що відповідає режиму транспортування літій-іонного акумулятора. Це стосується акумуляторів IMPRES 2 або IMPRES, які раніше ніколи не калібрувалися або потребують нового калібрування, а також інших оригінальних акумуляторів від Motorola Solutions, які не належать до типів IMPRES 2 або IMPRES.

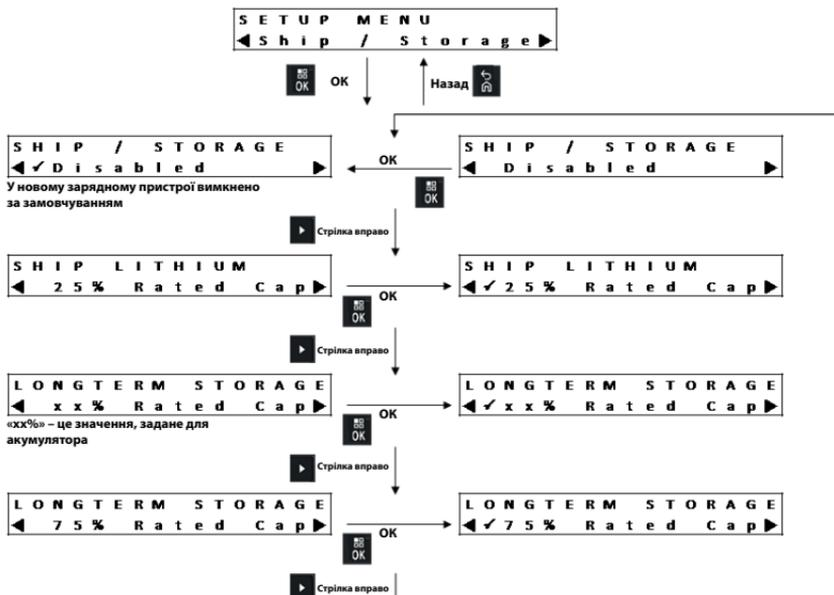
Режим транспортування літій-іонного акумулятора можна застосовувати тільки до оригінальних акумуляторів Motorola Solutions (IMPRES 2, IMPRES або інші літій-іонні акумулятори Motorola Solutions). Інші акумулятори (наприклад, невідомі або нікелеві акумулятори Motorola Solutions чи акумулятори Clamshell) спричиняють помилку.

## **Long-Term Storage (Тривале зберігання)**

Налаштування тривалого зберігання дає змогу зарядити акумулятори IMPRES 2 або IMPRES до стану заряду, прийнятого для тривалого зберігання. Зазвичай рівень заряду, розрахований на зберігання, значно нижчий, ніж повний заряд. Параметр  $xx\%$  є значенням, яке запрограмовано для акумуляторів IMPRES 2 або IMPRES або за замовчуванням становить 50 % від номінальної ємності. Налаштування «Long-Term Storage at 75 % Rated Capacity» (Тривале зберігання із зарядом 75 % від номінальної ємності) застосовується в ситуаціях, коли заряд акумулятора під час зберігання має залишатися на досить високому рівні, аби його не довелося довго заряджати, якщо пристрій буде потрібен негайно, або для забезпечення довшого терміну зберігання.

Деякі акумулятори IMPRES 2 або IMPRES можуть бути повністю розрядженими перед зарядженням до рівня, що відповідає параметрам тривалого зберігання. До таких акумуляторів належать, зокрема, акумулятори IMPRES 2 та IMPRES, які раніше не калібрувалися або потребують нового калібрування.

Режим тривалого зберігання можна застосовувати тільки до акумуляторів IMPRES 2 або IMPRES. Інші акумулятори (наприклад, невідомі або акумулятори Motorola Solutions, окрім IMPRES, чи акумулятори Clamshell) спричиняють помилку.

## **Акумулятори IMPRES 2 з режимом сну**

Деякі акумулятори IMPRES 2 підтримують режим сну (Sleep mode). Цей режим можна використовувати для збільшення часу до наступного зарядження акумулятора. Після завершення процесу зарядження для транспортування літій-іонного акумулятора або тривалого зберігання зарядний пристрій переведе такі акумулятори до режиму сну.

Установлення акумулятора IMPRES 2, який перебуває в режимі сну, у зарядний пристрій призведе до його виходу з цього режиму. Якщо акумулятор пройшов підготовку в режимі транспортування літій-іонного акумулятора, його встановлення в зарядний пристрій, налаштований на режим транспортування літій-іонного акумулятора, спричинить перехід акумулятора в режим сну. Якщо акумулятор пройшов підготовку в режимі тривалого зберігання, його встановлення в зарядний пристрій, налаштований на режим тривалого зберігання, спричинить перехід акумулятора до режиму сну.

## Меню калібрування

Пункти меню «Calibration» (Калібрування) дають змогу включити етап розряджання під час процесу калібрування/відновлення або пропустити цей етап. Розряджання передує етапу повного заряджання, яке є запорукою успішного калібрування/відновлення. Можливість пропустити етап розряджання стає в пригоді, коли потрібно якнайшвидше застосувати заряджений акумулятор. У цих випадках очікувати на повне розряджання може бути незручно.

Якщо акумулятор IMPRES 2 або IMPRES має пройти калібрування й уже був розряджений під час вставляння в зарядний пристрій, зарядний пристрій використовуватиме завершення заряджання як нагоду виконати калібрування акумулятора.



Рис. 7: Меню калібрування

## Меню повідомлення про закінчення терміну служби

Навіть якщо термін служби акумулятора IMPRES 2 або IMPRES добігає кінця, його ємність може бути більш ніж достатньою для полегшених умов експлуатації. Із цієї причини може бути бажаним вимкнення світлодіодної сигналізації закінчення терміну служби (індикатор **навперемінно червоний і зелений**).

У випадку з акумулятором APX NEXT XN вимкнення цієї індикації також вимикає індикацію кумулятивного впливу надмірної температури на акумулятор.

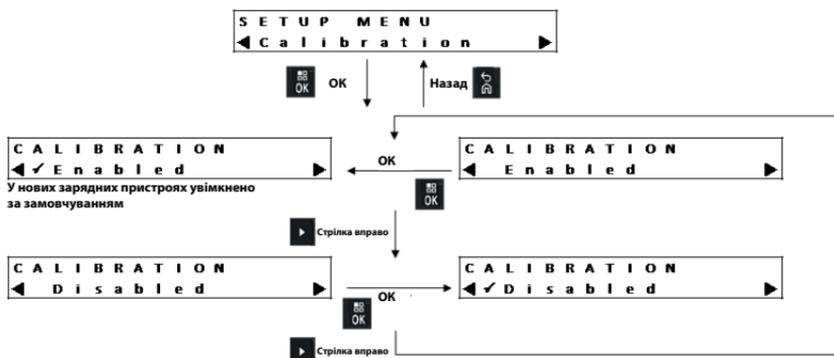

Рис. 8: Меню повідомлення про закінчення терміну служби

## Меню формату дисплея

Меню «Display Format» має чотири пункти:

- Normal – звичайна орієнтація (зарядний пристрій стоїть на столі).
- Inverted – обернена орієнтація (зарядний пристрій висить на стіні).
- Warnings only – лише попередження. Інші повідомлення не відображаються. Це налаштування застосовується як до звичайної, так і до оберненої орієнтації. Зразки попереджувальних повідомлень наведені в Табл. 6 – Табл. 12
- Під час штатної роботи дисплей вимкнено. Дисплей завжди активний у режимі налаштування (Setup Mode) та аналізу (Analyzer Mode).

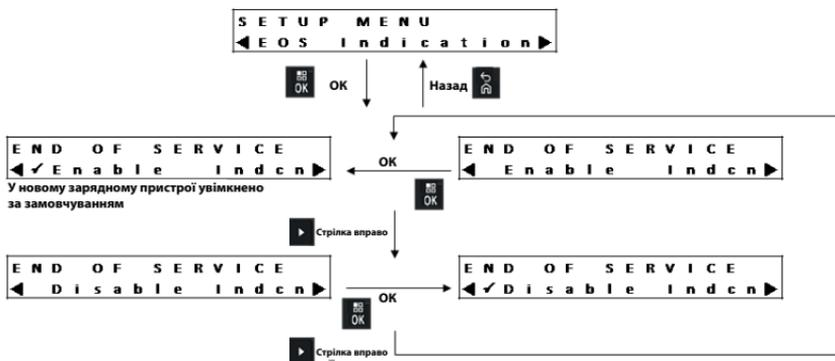

Рис. 9: Меню формату дисплея

## Меню формату вимірювання ємності

Ємність акумулятора відображається в одному з доступних форматів. Якщо ємність акумулятора відображається у відсотках, така відсоткова частка може стосуватися або потенційної ємності (повний заряд), або номінальної ємності. Зазвичай радіостанції IMPRES відображають ємність акумулятора у відсотках відносно потенційної ємності.



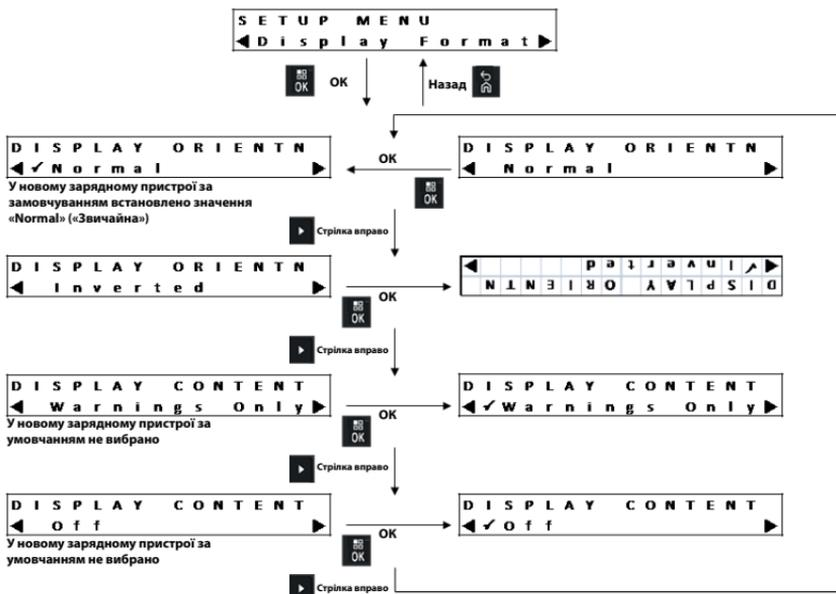

Рис. 10: Меню формату вимірювання ємності

Табл. 20: Параметри відображення ємності акумулятора

Формат	Опис
xxx0mAh	Наявний заряд (рівень заряду) в міліамперах на годину.
yyy%	Наявний заряд у відсотках відносно потенційної ємності або номінальної ємності. Коли ємність зазначено відносно потенційної ємності, її максимальне значення становить 100 %. Коли ємність зазначено відносно номінальної ємності, її максимальне значення може бути більше 100 %, особливо в нового акумулятора.
%BAR	Те саме, що і yyy%, але у вигляді шкали з восьми сегментів.

## Меню енергозбереження

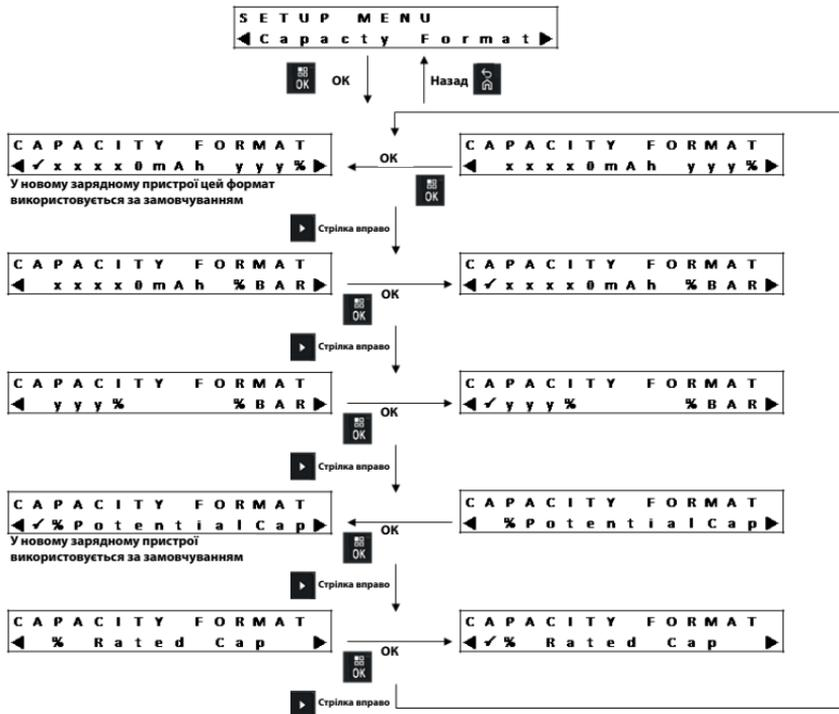
З метою дотримання визначених законодавствами деяких країн обмежень щодо споживання електроенергії приладами в режим очікування режим Power Saver (Енергозбереження) дає змогу автоматично вимикати всі гнізда, крім першого, якщо протягом певного часу не відбувається жодних подій. Подіями вважаються:

- заряджання радіостанції або акумулятора;
- калібрування/відновлення акумулятора;
- підготування оригінальних літій-іонних акумуляторів Motorola Solutions до транспортування;
- підготування акумулятора IMPRES 2 або IMPRES до тривалого зберігання;
- режим налаштування або режим аналізу зарядного пристрою;
- перепрограмування зарядного пристрою;
- зв'язок із системою керування парком акумуляторів IMPRES;
- блимання будь-якого світлодіодного індикатора.



Рис. 11: Меню енергозбереження

Гніздо № 1 залишається ввімкненим, але може перейти в режим сну. Щоб увімкнути інші гнізда, натисніть будь-яку кнопку на клавіатурі. Доки інші гнізда не буде ввімкнено, вони не реагуватимуть на вставляння або виймання радіостанцій або акумуляторів.

## Меню тривалості входу

Тривалістю входу є час утримання кнопки після її натискання, потрібний для входу зарядного пристрою в режим налаштування (Setup) або аналізу (Analyzer).

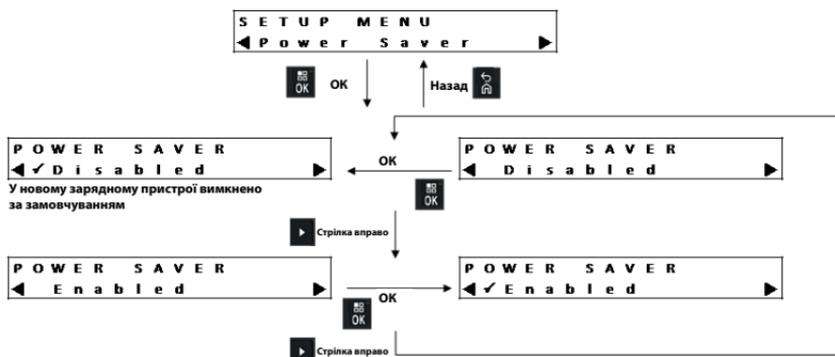

Рис. 12: Меню тривалості входу

## Меню вибору мови

Наразі дисплей зарядного пристрою цієї моделі підтримує одну мову: англійська (США).

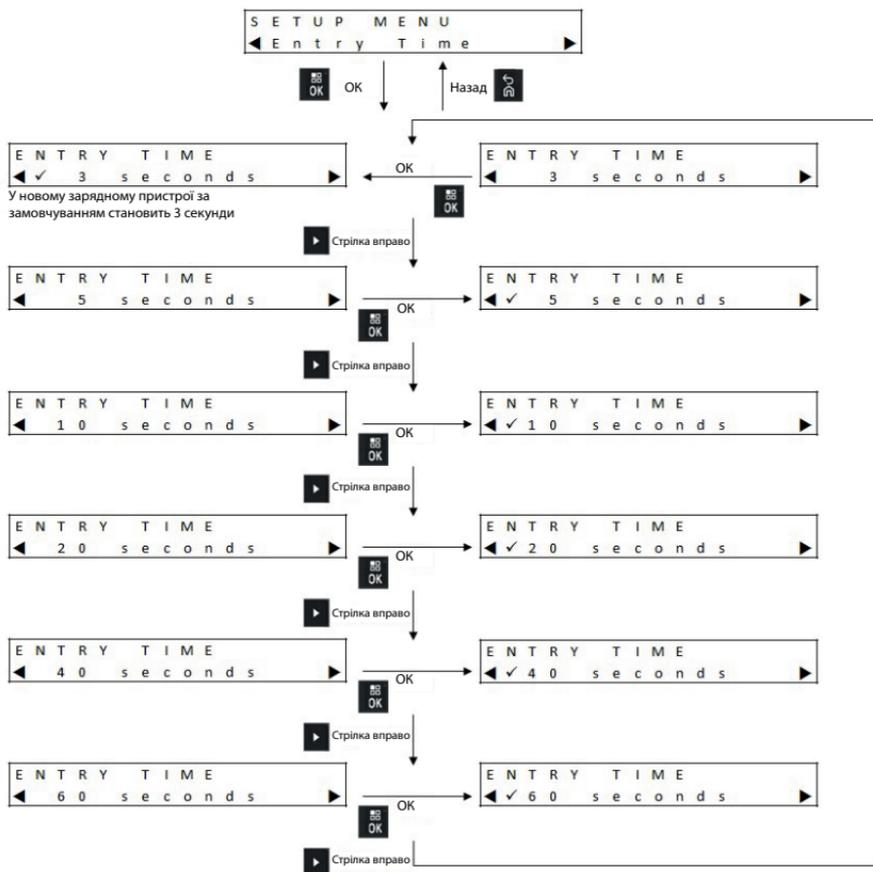

Рис. 13: Меню вибору мови

## Режим аналізу

Клавіатуру зарядного пристрою розташовано під дисплеєм гнізда № 1.

Щоб увійти до режиму аналізу, натисніть та утримуйте кнопку «OK» довше вибраної тривалості входу (за замовчуванням це 3 секунди).

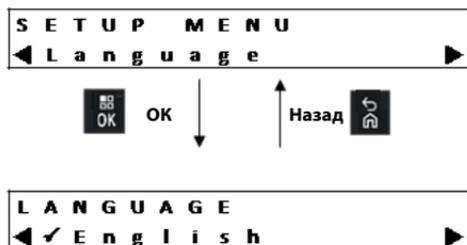

Рис. 14: Кнопка меню дисплея для входу в режим аналізу

Після входу в режим аналізу відображається таке повідомлення:

Press OK to entr  
ANALYZER MODE

Після натискання кнопки «OK» буде відображена доступна інформація про акумулятор.

## Режим аналізу версії V1.0

У версії програмного забезпечення V1.0 режим аналізу доступний тільки для гнізда № 1. Інформація аналізатора щодо гнізда № 1 та його вмісту відтворюється на дисплеї гнізда № 1. Якщо впродовж 10 хвилин не натиснуто жодної кнопки, зарядний пристрій самостійно вийде з режиму аналізу та повернеться до звичайного відображення повідомлень.



Рис. 15: Меню режиму аналізу версії V1.0

## Режим аналізу версії V1.05

Режим аналізу було вдосконалено у версії програмного забезпечення V1.05. Для зарядних пристроїв з окремими дисплеями для кожного гнізда інформація аналізатора відображається на дисплеї, розташованому поруч із відповідним гніздом. Під час перегляду інформації аналізатора гнізда № 1 інші дисплеї відображають інформацію аналізатора, яка стосується відповідного гнізда, розташованого поруч.

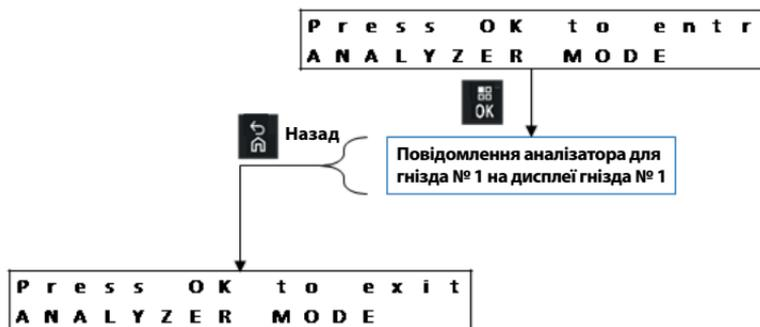

Рис. 16: Меню режиму аналізу версії V1.05

## Режим аналізу версії V1.11.01

Режим аналізу було вдосконалено ще раз у версії програмного забезпечення V1.11.01. Для зарядних пристроїв із дисплеєм лише для гнізда № 1 меню дисплея гнізда № 1 використовується для відображення інформації, що стосується будь-якого іншого гнізда зарядного пристрою. Також у цій версії залишились удосконалення з версії V1.05.

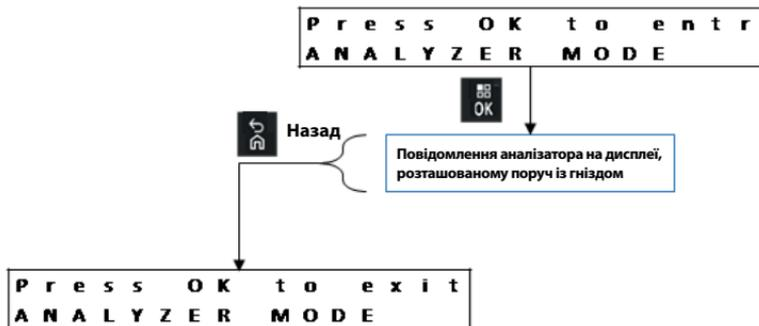

Рис. 17: Меню режиму аналізу версії V1.11.01

## Заміна акумуляторів у гнізді

Якщо витягнути акумулятор, а потім уставити в те ж гніздо такий самий або інший акумулятор, параметр, відображений для другого акумулятора, буде аналогічним до того, що відображався для першого акумулятора.

Наприклад, для акумулятора типу IMPRES 2 або IMPRES відображається параметр `Battery IMPRES Cycles` (Кількість циклів акумулятора IMPRES). Цей акумулятор витягають із гнізда. Інший акумулятор IMPRES 2 або IMPRES вставляють у це саме гніздо. Перший параметр, що відображається для другого акумулятора: `Battery IMPRES Cycles` (Кількість циклів акумулятора IMPRES).

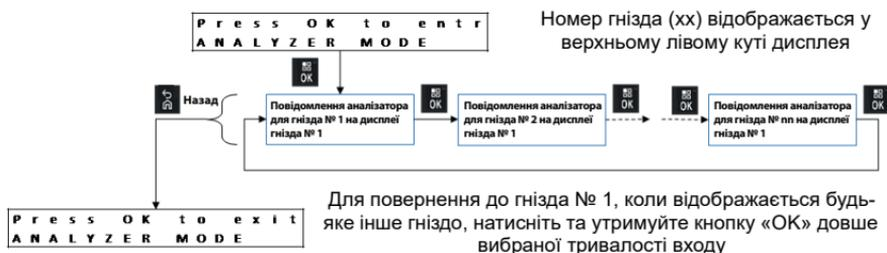
Однак другий акумулятор може не підтримувати той параметр, який відображався для першого акумулятора. У такому разі для другого акумулятора відображається ідентифікаційне повідомлення.

# Акумулятор IMPRES 2

## Дисплей, розташований поруч із гніздом



Рис. 18: Меню режиму аналізу акумулятора IMPRES 2 для дисплея, розташованого поруч з гніздом



## Дисплей гнізда № 1 відображає дані іншого гнізда

Номер гнізда (xx)  
відображається у верхньому  
лівому куті дисплея

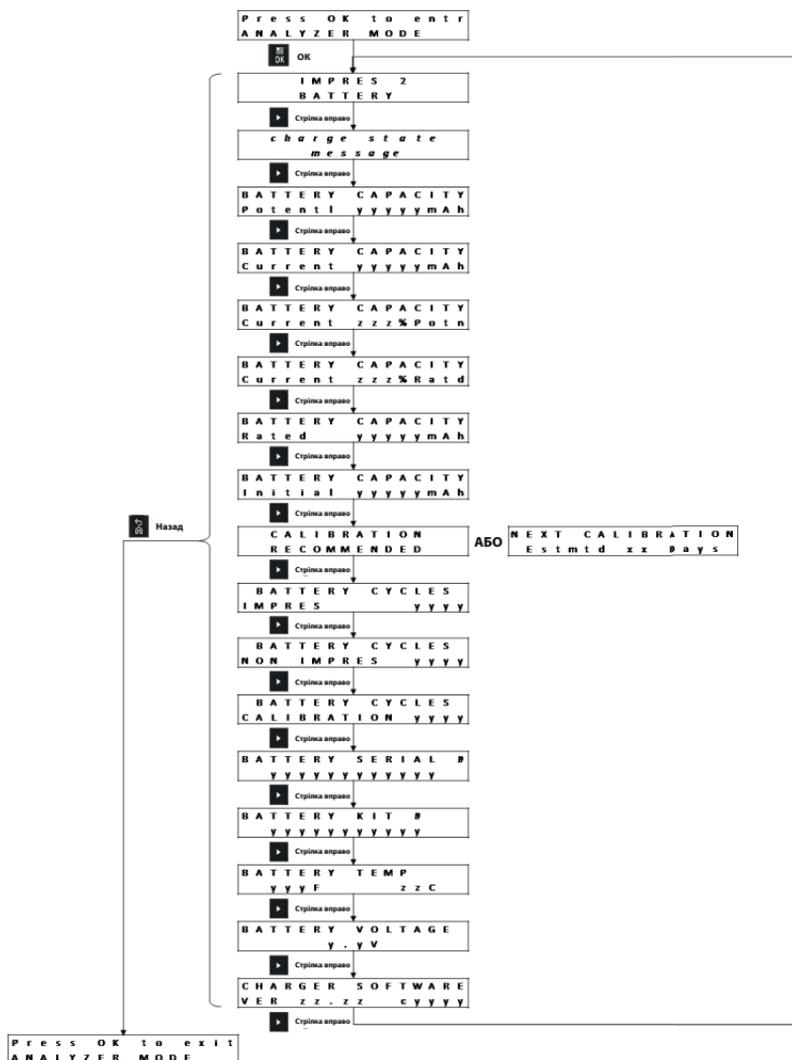

Рис. 19: Меню режиму аналізу акумулятора IMPRES 2 для іншого гнізда (окрім гнізда № 1)

# Акумулятор IMPRES

## Дисплей, розташований поруч із гніздом

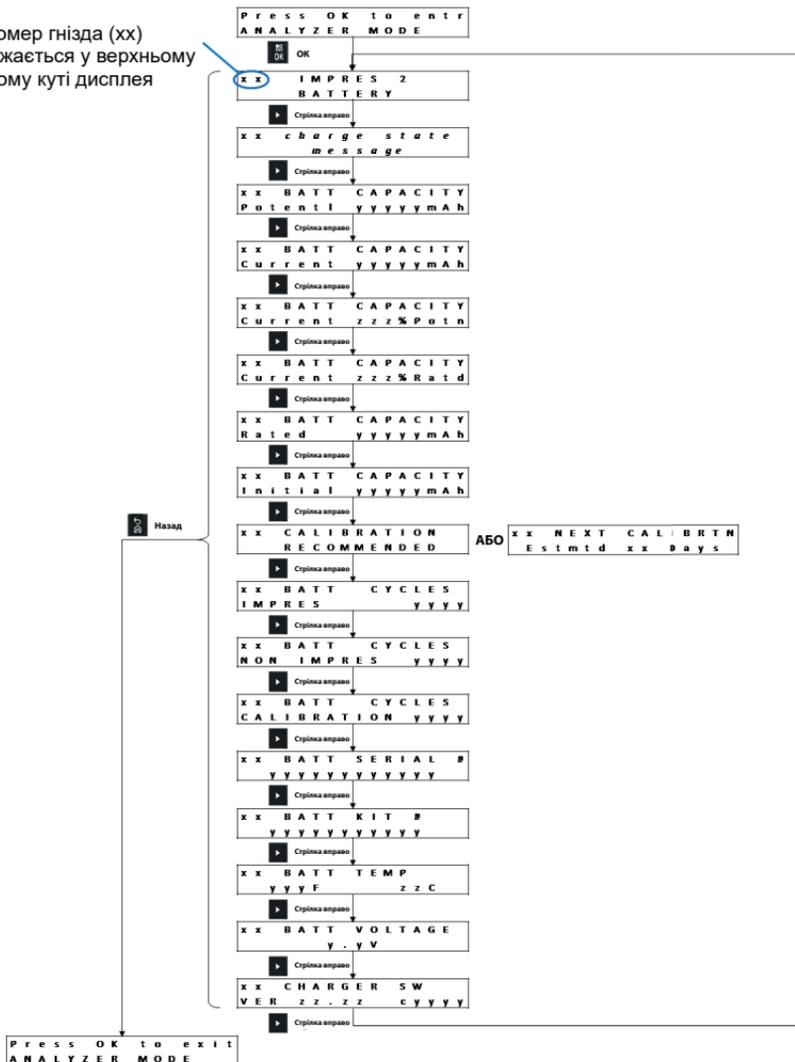

Рис. 20: Меню режиму аналізу акумулятора IMPRES для дисплея, розташованого поруч із гніздом

Українська

## Дисплей гнізда № 1 відображає дані іншого гнізда

Номер гнізда (xx)  
відображається у верхньому  
лівому куті дисплея

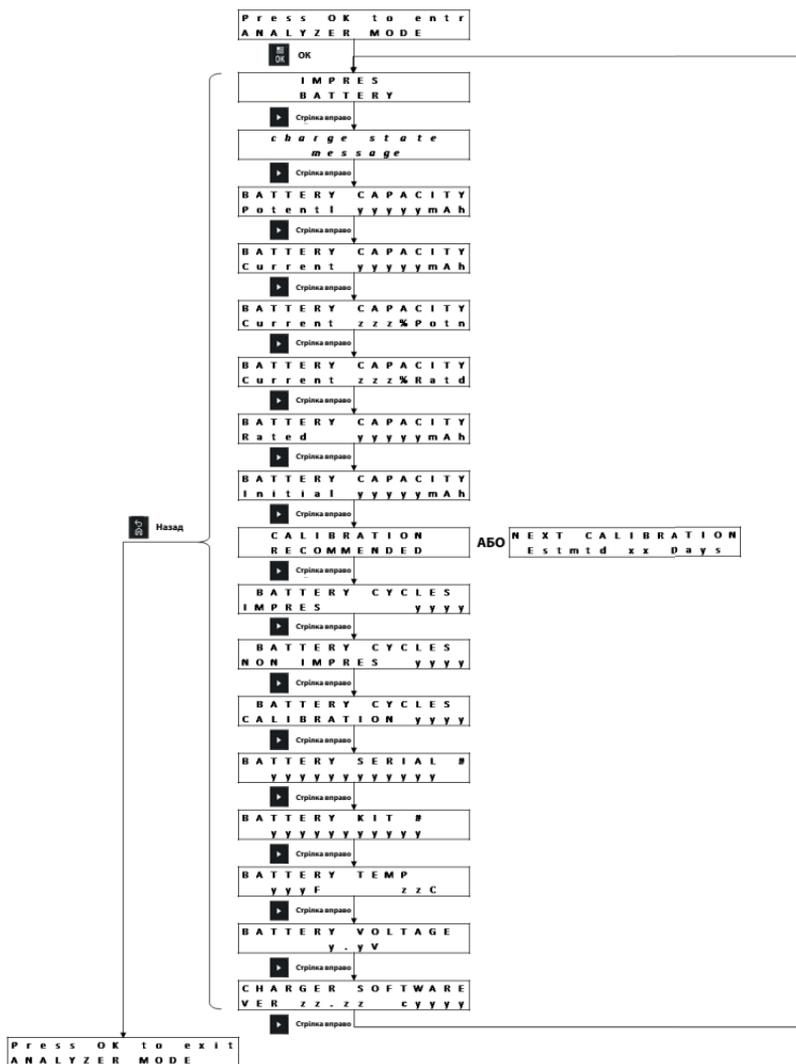

Рис. 21: Меню режиму аналізу акумулятора IMPRES для іншого гнізда (окрім гнізда № 1)

## Інші акумулятори від Motorola Solutions

### Дисплей, розташований поруч із гніздом

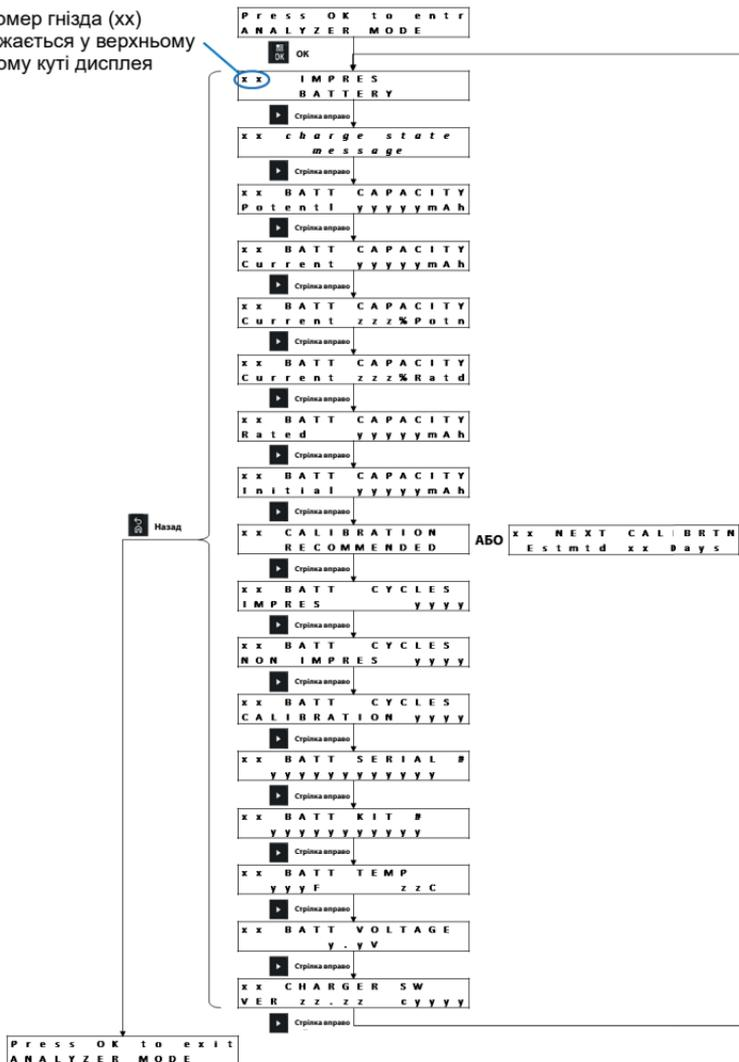

Рис. 22: Меню режиму аналізу інших акумуляторів від Motorola Solutions для дисплея, розташованого поруч із гніздом

## Дисплей гнізда № 1 відображає дані іншого гнізда

Номер гнізда (xx)  
відображається у верхньому  
лівому куті дисплея

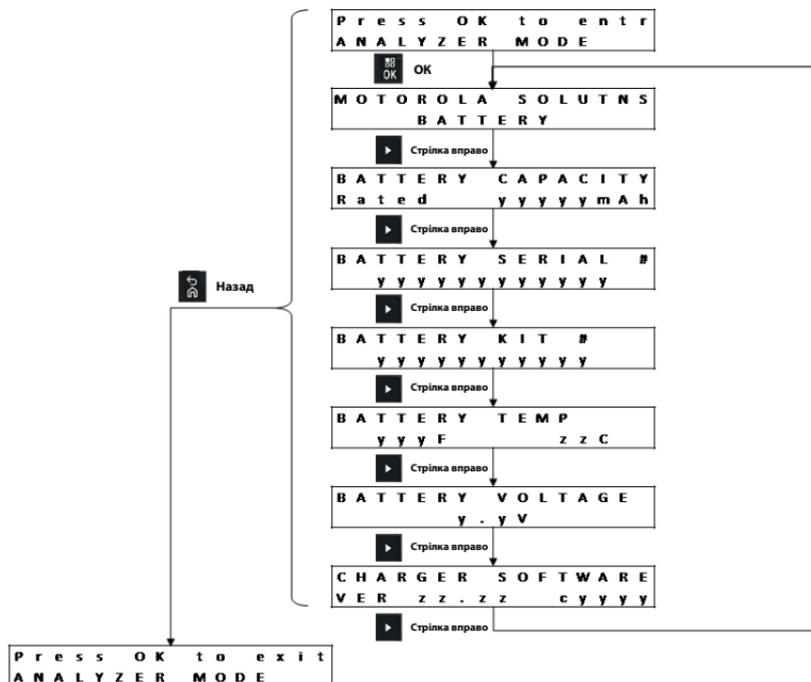

Рис. 23: Меню режиму аналізу інших акумуляторів від Motorola Solutions для іншого гнізда (окрім гнізда № 1)

## Невідомий тип акумулятора

### Дисплей, розташований поруч із гніздом

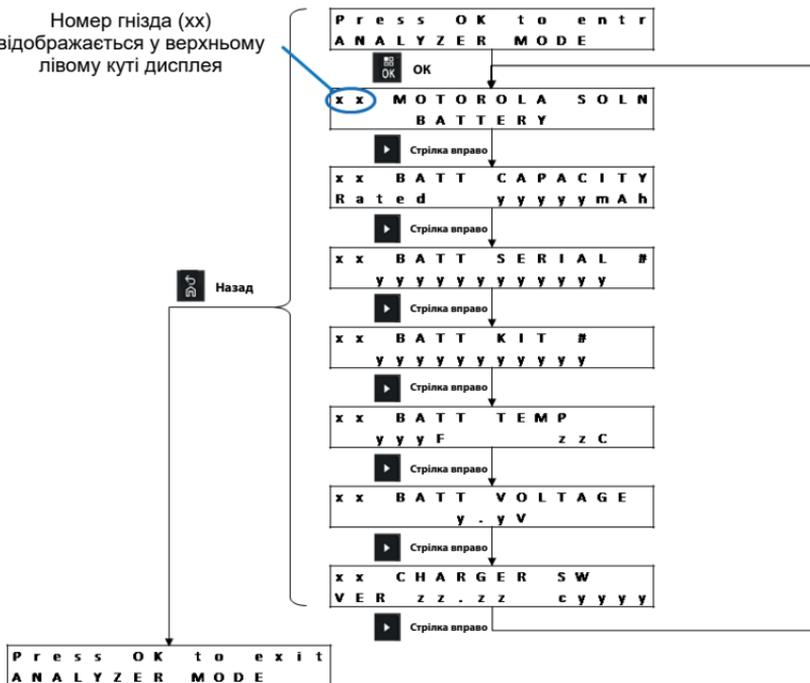

Рис. 24: Меню режиму аналізу невідомого типу акумулятора для дисплея, розташованого поруч із гніздом

### Дисплей гнізда № 1 відображає дані іншого гнізда

Номер гнізда (xx) відображається у верхньому лівому куті дисплея

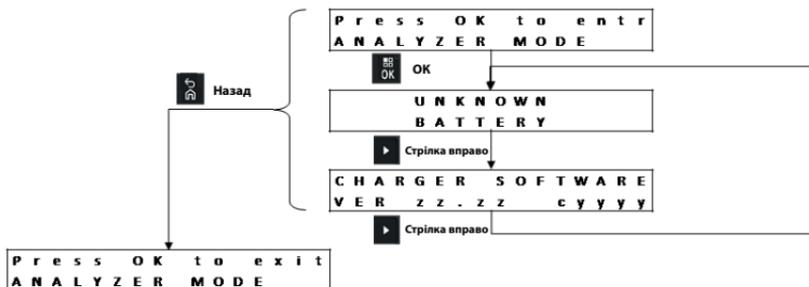

Рис. 25: Меню режиму аналізу невідомого типу акумулятора для іншого гнізда (окрім гнізда № 1)

## Вільне гніздо

### Дисплей, розташований поруч із гніздом

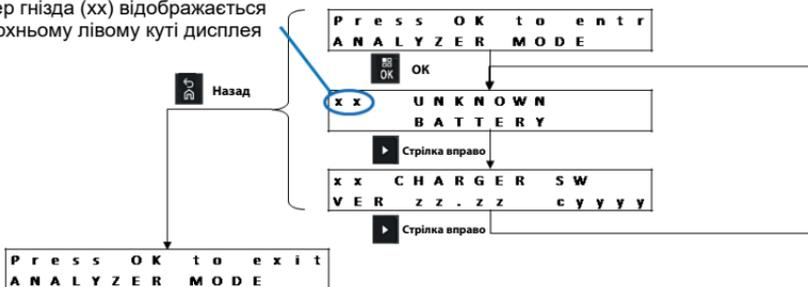

Рис. 26: Меню режиму аналізу для вільного гнізда, розташованого поруч із дисплеєм

### Дисплей гнізда № 1 відображає дані іншого гнізда

Номер гнізда (xx) відображається у верхньому лівому куті дисплея

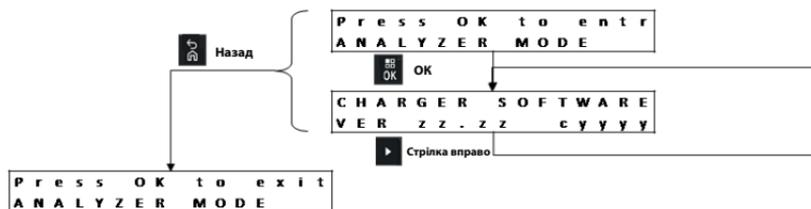

Рис. 27: Меню режиму аналізу для вільного гнізда (окрім гнізда № 1)

### Повідомлення про стан зарядного пристрою

Деякі акумулятори IMPRES 2 підтримують режим сну (Sleep mode). На завершення режимів підготовки літій-іонного акумулятора до транспортування, тривалого зберігання з зарядом xxx % або 75 % від номінальної ємності акумулятори, у яких передбачено режим сну, переходять у цей режим. Переглянувши повідомлення про стан заряду в меню режиму аналізу, ви зможете дізнатися про стан заряду акумуляторів, що перебувають у режимі сну.

**Табл. 21:** Увімкнено режим підготовки літійового акумулятора до транспортування, і акумулятор отримав відповідний заряд

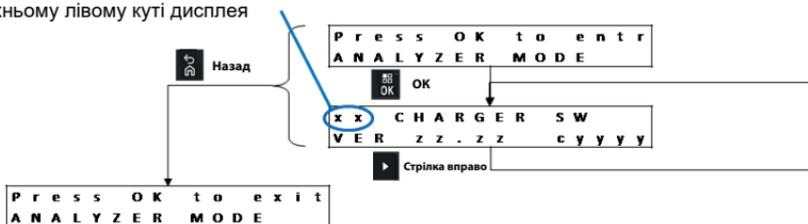
Дисплей, розташований поруч із гніздом	Дисплей гнізда № 1 відображає дані іншого гнізда
SHIP LI SLEEP xxx% Rated Cap	xx SHIP LI SLEEP xxx% Rated Cap

**Табл. 22:** Увімкнено режим підготовки до тривалого зберігання з зарядом xx %, і акумулятор отримав відповідний заряд

Дисплей, розташований поруч із гніздом	Дисплей гнізда № 1 відображає дані іншого гнізда
STORAGE SLEEP xxx% Rated Cap	xx STORAGE SLEEP xxx% Rated Cap

Наприклад, повідомлення про стан зарядного пристрою не відображається, якщо активовано режим підготовки до тривалого зберігання з зарядом xx %, а акумулятор був заряджений для тривалого зберігання з зарядом 75 % в іншому зарядному пристрої.

## Перепрограмування зарядного пристрою

Для перепрограмування зарядного пристрою потрібно підключити модуль обміну даними до комп'ютера за допомогою стандартного USB-кабелю. Для запуску процесу перепрограмування використовується система керування парком акумуляторів IMPRES. На дисплеї зарядного пристрою з'являються вказані далі повідомлення.

Запит на виймання акумуляторів із гнізд зарядного пристрою перед перепрограмуванням:

REPROGRAMMING  
REMOVE BATTERIES

Усі гнізда вільні:

REPROGRAMMING  
WAITING FOR DATA

Завантажуються дані для перепрограмування:

REPROGRAMMING  
Progress yyy%



Якщо на зарядному пристрої кожне гніздо має окремий дисплей, відображуване на ньому значення у відсотках показує, скільки відсотків даних успішно завантажено у відповідне гніздо. Якщо зарядний пристрій має лише один дисплей (для гнізда № 1), значення у відсотках показує, скільки всього даних було завантажено в усі гнізда.

Помилка перепрограмування певного гнізда:

```
REPROGRAMMING  
POCKET#xx FAILED
```

Гніздо зарядного пристрою з зазначеним номером буде працювати у звичайному режимі з попередньою версією ПЗ.

Завантаження даних для перепрограмування завершено.

Зарядження є завершальним етапом процесу перепрограмування.

```
IMPRES 2  
CHARGER
```

Процес перепрограмування успішно завершено.

```
REPROGRAMMING  
COMPLETE
```

Зарядний пристрій почне працювати у звичайному режимі зі щойно завантаженим ПЗ. Після завершення перепрограмування зарядного пристрою користувацькі налаштування буде збережено.

## Усунення несправностей

**Табл. 23:** Усунення несправностей:  
звичайне зарядження

Проблема	Рішення
Зелений світлодіодний індикатор гнізда не миготить протягом приблизно 1 секунди після ввімкнення зарядного пристрою.	Перевірте, чи надійно вставлено шнур живлення в зарядний пристрій і розетку мережі живлення змінного струму. Перевірте, чи надходить електроенергія до цієї розетки. Перевірте плавкі запобіжники, за потреби замініть їх.

**Табл. 23:** Усунення несправностей:  
звичайне заряджання (продовження)

Проблема	Рішення
<p>Акумулятор або радіостанцію вставлено в гніздо, але світлодіодний індикатор цього гнізда залишається вимкненим, а акумулятор не ідентифікується на розташованому поруч із гніздом дисплеї.</p>	<p>Якщо це гніздо не є гніздом № 1 та активовано режим енергозбереження (Power Saver), натисніть кнопку меню. Див. нижче.</p>
<p>Червоний світлодіодний індикатор блимає, а на дисплеї (якщо є) відображається: NOT CHARGEABLE REMOVE&amp; REINSERT або акумулятор Motorola Solutions установлено в гнізді, але на дисплеї (якщо є) відображається: UNKNOWN BATTERY</p>	<p>Вийміть акумулятор або радіопристрій із гнізда. Перевірте електричні контакти акумулятора й гнізда зарядного пристрою на предмет забруднення, корозії або фізичних пошкоджень. Переконайтеся, що акумулятор належить до переліку акумуляторів, схвалених компанією Motorola Solutions. Акумулятори інших моделей не завжди можливо зарядити. Протріть контакти акумулятора сухою тканиною. Вимкніть живлення зарядного пристрою, а потім протріть електричні контакти гнізда сухою тканиною. Спробуйте вставити в це гніздо інший акумулятор. Якщо це допомогло усунути проблему, виведіть несправний акумулятор з експлуатації. Якщо проблема повторюється з іншим акумулятором, виведіть зарядний пристрій з експлуатації.</p>
<p>Після завершення калібрування навперемінно блимають червоний і зелений індикатори.</p>	<p>Термін служби акумулятора IMPRES 2 або IMPRES може добігати кінця. Такий акумулятор придатний для використання, однак доступна ємність може бути замалою для складних умов експлуатації протягом тривалого часу. Стосується лише акумулятора APX NEXT XN: акумулятор піддавався впливу високої температури більше 10 хвилин. Цей акумулятор рекомендується вилучити з експлуатації.</p>

Українська

**Табл. 23:** Усунення несправностей:  
звичайне заряджання (продовження)

Проблема	Рішення
Після під'єднання  акумулятора до зарядного пристрою напереми́нно протягом 4 секунд блимають жовтий і зелений індикатори.	Акумулятор IMPRES 2 або IMPRES потребує калібрування/ відновлення. За наступної можливості встановіть акумулятор у зарядний пристрій IMPRES 2 з активованою функцією калібрування й дайте змогу зарядному пристрою завершити калібрування (постійний зелений).
У режимі аналізу дисплей гнізда № 1 може відображати дані іншого гнізда.	Зарядний пристрій не може визначити дані для відображення щонайменше від одного з інших гнізд.

**Табл. 24:** Усунення несправностей: заряджання для тривалого зберігання

Проблема	Рішення
Червоний світлодіодний індикатор блимає, а на дисплеї (якщо є) відображається: WRONG BATT TYPE CANNOT LT STORE АБО CANNOT DISCHARGE CANNOT LT STORE 	Вийміть акумулятор із гнізда. Переконайтеся, що акумулятор HE приєднано до радіопристрою. Переконайтеся, що акумулятор належить до типу IMPRES 2 або IMPRES. Акумулятори інших типів спричинять помилку. Протріть електричні контакти акумулятора IMPRES 2 або IMPRES сухою тканиною. Вимкніть живлення зарядного пристрою, а потім протріть електричні контакти гнізда сухою тканиною. Спробуйте замінити акумулятор на інший акумулятор IMPRES 2 або IMPRES. Якщо це допомогло усунути проблему, виведіть несправний акумулятор IMPRES 2 або IMPRES з експлуатації. Якщо проблема повторюється з іншими акумуляторами IMPRES 2 або IMPRES, виведіть зарядний пристрій з експлуатації.

**Табл. 24:** Усунення несправностей: заряджання для тривалого зберігання (продовження)

Проблема	Рішення
<p>Червоний світлодіодний індикатор блимає, а на дисплеї (якщо є) відображається:</p> <p>STORE INCOMPLETE Low Capacity:yy%</p>	<p>Потенційна ємність акумулятора IMPRES 2 або IMPRES може бути меншою, ніж значення, вибране для тривалого зберігання. Термін служби такого акумулятора може добігати кінця.</p>
<p>Червоний світлодіодний індикатор блимає, а на дисплеї (якщо є) відображається:</p> <p>RADIO POCKET CANNOT LT STORE</p> <p>АБО</p> <p>CHARGING POCKET CANNOT LT STORE</p>	<p>Гніздо зарядного пристрою не є стандартним гніздом для заряджання акумулятора (через електричні контакти між зарядним пристроєм та акумулятором).</p> <ul style="list-style-type: none"> <li>Гніздо для радіопристрою є спеціальним гніздом, у якому акумулятор з'єднується з радіопристроєм, тобто акумулятор не має зовнішніх контактів і заряджається через електричні контакти радіопристрою.</li> <li>Зарядне гніздо є таким, у якому енергія зарядного пристрою використовується для особливої мети, наприклад живлення зарядних портів USB.</li> </ul> <p>Переставте акумулятор у стандартне гніздо або замініть гніздо для радіопристрою або зарядне гніздо на стандартне.</p>

**Табл. 25:** Усунення несправностей: заряджання для транспортування літій-іонного акумулятора

Проблема	Рішення
<p>Червоний світлодіодний індикатор блимає, а на дисплеї (якщо є) відображається:</p> <p>WRONG BATT TYPE CANNOT SHIP LI</p>	<p>Вийміть акумулятор із гнізда. Переконайтеся, що акумулятор HE приєднано до радіопристрою.</p> <p>Переконайтеся, що акумулятор належить до типів IMPRES 2, IMPRES або є іншим літій-іонним акумулятором, схваленим компанією Motorola Solutions. Акумулятори інших типів спричинять помилку.</p> <p>Протріть електричні контакти акумуляторів IMPRES 2, IMPRES або іншого літій-іонного акумулятора, схваленого компанією Motorola Solutions, сухою тканиною.</p> <p>Вимкніть живлення зарядного пристрою, а потім протріть електричні контакти гнізда сухою тканиною.</p> <p>Спробуйте замінити акумулятор на інший акумулятор IMPRES 2, IMPRES або літій-іонний акумулятор, схвалений компанією Motorola Solutions. Якщо це допомогло усунути проблему, виведіть з експлуатації несправний акумулятор IMPRES 2, IMPRES або літій-іонний акумулятор, схвалений компанією Motorola Solutions.</p> <p>Якщо проблема повторюється з іншими акумуляторами IMPRES 2, IMPRES або літій-іонним акумулятором, схваленим компанією Motorola Solutions, виведіть зарядний пристрій з експлуатації.</p>
<p>Червоний світлодіодний індикатор блимає, а на дисплеї (якщо є) відображається:</p> <p>SHIP INCOMPLETE Low Capacity:yy%</p>	<p>Потенційна ємність оригінального літій-іонного акумулятора Motorola Solutions може бути меншою, ніж рівень заряду для транспортування літій-іонного акумулятора. Термін служби такого акумулятора може добігати кінця.</p>

**Табл. 25:** Усунення несправностей: заряджання для транспортування літій-іонного акумулятора (продовження)

Проблема	Рішення
<p>Червоний світлодіодний індикатор блимає, а на дисплеї (якщо є) відображається:</p> <p>RADIO POCKET CANNOT LT STORE</p> <p>АБО</p> <p>CHARGING POCKET CANNOT SHIP LI</p>	<p>Гніздо зарядного пристрою не є стандартним гніздом для заряджання акумулятора (через електричні контакти між зарядним пристроєм та акумулятором).</p> <ul style="list-style-type: none"> <li>Гніздо для радіопристрою є спеціальним гніздом, у якому акумулятор з'єднується з радіопристроєм, тобто акумулятор не має зовнішніх контактів і заряджається через електричні контакти радіопристрою.</li> <li>Зарядне гніздо є таким, у якому енергія зарядного пристрою використовується для особливої мети, наприклад живлення зарядних портів USB.</li> </ul> <p>Переставте акумулятор у стандартне гніздо або замініть гніздо для радіопристрою або зарядне гніздо на стандартне.</p>

## Система Battery Fleet Management IMPRES

Програмне забезпечення для керування парком акумуляторів IMPRES Battery Fleet Management автоматично збирає важливі дані з акумуляторів класу IMPRES або IMPRES 2 під час заряджання в пристрої IMPRES. Важливими є дані про термін використання, ємність, кількість циклів заряджання та історію калібрувань/ відновлень, дату виробництва та дату введення в експлуатацію. Програма Battery Fleet Management IMPRES аналізує отримані дані, повідомляє про фізичний стан акумуляторів і надає рекомендації щодо їхньої заміни. Це дає змогу швидко й ефективно розв'язувати питання щодо можливості використання вживаних акумуляторів на менш відповідальних ділянках, купівлі нових акумуляторів на заміну, а також виявляти нестачу акумуляторів.

Система Battery Fleet Management IMPRES надає важливі дані щодо стану акумуляторів:

- Сигналізує про зменшення ємності акумулятора до неприпустимого рівня.
- Дає користувачу впевненість у тому, що ємності вистачить на всю робочу зміну.
- Виявляє акумулятори малої ємності, які вже час виводити з експлуатації.
- Запобігає непередбачуваним перервам і перебоям у роботі.
- Допомогає уникнути зайвих витрат через передчасне виведення акумуляторів з експлуатації.

- Забезпечує оптимальний розподіл і використання зарядних пристроїв.

Програма Battery Fleet Management IMPRES є масштабованим програмним засобом, який можна пристосувати і до потреб підприємств з одним об'єктом, і до потреб складних розгалужених систем, як показано на Рис. 28. Система керування парком акумуляторів IMPRES підтримує:

- один сервер адміністрування системи;
- 19 віддалених клієнтів;
- 25 зарядних пристроїв IMPRES або зчитувальних пристроїв для акумуляторів IMPRES на кожного клієнта;
- 25 000 акумуляторів IMPRES на одному об'єкті або на географічно розділених ділянках (загальна кількість акумуляторів у системі не повинна перевищувати 25 000).



**Рис. 28:** Керування акумуляторами IMPRES за допомогою мережі зарядних пристроїв

Система керування парком акумуляторів IMPRES складається з трьох основних компонентів:

- прикладне програмне забезпечення;
- ліцензійний ключ;
- кабель USB для підключення зарядного пристрою IMPRES 2, комунікаційного модуля IMPRES 2, інтерфейсного блока зарядного пристрою IMPRES або зчитувача даних акумулятора IMPRES до основного комп'ютера, на якому встановлений віддалений клієнт.

Використовуйте наявні звіти для створення власних звітів, щоб отримувати інформацію, яка є необхідною для вашої організації. Дані зберігаються у вашій базі даних; їх можна експортувати у файл Excel™ або роздрукувати. Програма керування парком акумуляторів IMPRES збирає та структурує велику кількість даних, завдяки чому ви можете:

- переглянути миттєвий звіт про стан всього парку акумуляторів;
- оцінювати відповідність акумуляторів вашим критеріям продуктивності;
- визначати, які акумулятори найближчим часом доведеться замінити;
- вирішувати, коли саме потрібно купувати нові акумулятори;
- отримувати звіт про загублені акумулятори;
- оптимізувати процес використання зарядних пристроїв;
- стежити за всіма пристроями в межах системи.

Serial Number	Alias	Group	Radio Family	ISE Number	Chemistry	ISE	Rated Capacity	Potential Capacity	Date of First Use
100000185479	Sam	Building 1	VT5 5000/3500/2000	HW000118	NiCd	No	1823	1891	01/11/2009
100000185480	Max	Security	APR	WNTN7973A	NiMH	No	2100	1680	03/15/2009
100000185488	Michael	Security	APR	WNTN7973A	NiMH	Yes	2000	1600	01/04/2009
100000185511	Paul	Administration	HT102/PRO Series	HW00028A	NiCd	No	1550	1240	01/4/2009
100000185512	Paula	Building 1	VT5 5000/3500/2000	WNTN4978	NiMH	Yes	1900	1360	07/24/2009
100000185538	Richard	Building 1	VT5 2000/3750/1975/1550	WNTN7973A	Li-Ion	No	2000	2440	01/04/2009
100000185811	Active	Home	APR	HW000128	NiCd	No	2000	1600	01/5/2009
100000185813	Mark	Building 2	VT5 2000/3750/1975/1550	WNTN7973A	Li-Ion	No	2000	1440	01/11/2009
100000185814	Gene	Building 1	VT5 2000/3750/1975/1550	WNTN7973A	Li-Ion	No	2000	1440	01/2/2009
100000186120	Bob	Home	APR	HW00028A	NiCd	Yes	2000	1600	05/17/2009
100000186221	Carl	Administration	HT102/PRO Series	HW00028A	NiMH	Yes	1600	1100	01/12/2009
100000411387	Paul	Building 1	VT5 5000/3500/2000	WNTN4978	NiMH	Yes	2000	1200	02/11/2008
100000411200	Steve	Building 1	VT5 5000/3500/2000	HW000118	NiCd	No	1823	1080	01/5/2009
100000538903	John	Security	APR	WNTN7973A	Li-Ion	Yes	1600	2911	01/21/2009
100000539202	Frank	Building 1	VT5 5000/3500/2000	WNTN7973A	NiMH	No	2100	1491	01/11/2008
100000641717	Mark	Building 2	VT5 5000/3500/2000	WNTN7973A	Li-Ion	Yes	1950	2804	01/18/2009
100000642208	Doc	Administration	HT102/PRO Series	HW00028A	Li-Ion	No	2100	1528	01/20/2009
100000643370	Mary	Administration	HT102/PRO Series	HW00028A	NiCd	No	1550	1100	01/10/2009
100000643915	Paul	Building 1	APR	WNTN7973A	NiMH	No	2100	1491	01/2/2009
100000643922	Tom	Security	APR	WNTN7973A	Li-Ion	Yes	1600	2911	01/20/2009
100000643927	Will	Administration	HT102/PRO Series	HW00028A	NiCd	No	1550	1100	01/10/2009
100000644221	Joe	Building 2	VT5 5000/3500/2000	HW00028A	NiMH	No	2000	2079	01/6/2007
100000644230	Paul	Administration	HT102/PRO Series	HW00028A	Li-Ion	Yes	1400	166	01/12/2009
100000647223	Frank	Building 1	APR	WNTN7973A	NiMH	No	2100	1380	01/20/2008
100000647224	Tom	Security	APR	WNTN7973A	Li-Ion	Yes	1400	166	01/12/2007
100000647225	Tom	Security	APR	WNTN7973A	NiMH	No	2100	1444	01/11/2008
100000647226	Tom	Security	APR	WNTN7973A	Li-Ion	Yes	1400	166	01/12/2007
100000647227	Tom	Security	APR	WNTN7973A	NiMH	No	2100	1444	01/11/2008
100000647228	Tom	Security	APR	WNTN7973A	Li-Ion	Yes	1400	166	01/12/2007
100000647229	Tom	Security	APR	WNTN7973A	NiMH	No	2100	1444	01/11/2008
100000647230	Tom	Security	APR	WNTN7973A	Li-Ion	Yes	1400	166	01/12/2007
100000647231	Tom	Security	APR	WNTN7973A	NiMH	No	2100	1444	01/11/2008
100000647232	Tom	Security	APR	WNTN7973A	Li-Ion	Yes	1400	166	01/12/2007
100000647233	Tom	Security	APR	WNTN7973A	NiMH	No	2100	1444	01/11/2008
100000647234	Tom	Security	APR	WNTN7973A	Li-Ion	Yes	1400	166	01/12/2007
100000647235	Tom	Security	APR	WNTN7973A	NiMH	No	2100	1444	01/11/2008
100000647236	Tom	Security	APR	WNTN7973A	Li-Ion	Yes	1400	166	01/12/2007
100000647237	Tom	Security	APR	WNTN7973A	NiMH	No	2100	1444	01/11/2008
100000647238	Tom	Security	APR	WNTN7973A	Li-Ion	Yes	1400	166	01/12/2007
100000647239	Tom	Security	APR	WNTN7973A	NiMH	No	2100	1444	01/11/2008
100000647240	Tom	Security	APR	WNTN7973A	Li-Ion	Yes	1400	166	01/12/2007
100000647241	Tom	Security	APR	WNTN7973A	NiMH	No	2100	1444	01/11/2008
100000647242	Tom	Security	APR	WNTN7973A	Li-Ion	Yes	1400	166	01/12/2007
100000647243	Tom	Security	APR	WNTN7973A	NiMH	No	2100	1444	01/11/2008
100000647244	Tom	Security	APR	WNTN7973A	Li-Ion	Yes	1400	166	01/12/2007
100000647245	Tom	Security	APR	WNTN7973A	NiMH	No	2100	1444	01/11/2008
100000647246	Tom	Security	APR	WNTN7973A	Li-Ion	Yes	1400	166	01/12/2007
100000647247	Tom	Security	APR	WNTN7973A	NiMH	No	2100	1444	01/11/2008
100000647248	Tom	Security	APR	WNTN7973A	Li-Ion	Yes	1400	166	01/12/2007
100000647249	Tom	Security	APR	WNTN7973A	NiMH	No	2100	1444	01/11/2008
100000647250	Tom	Security	APR	WNTN7973A	Li-Ion	Yes	1400	166	01/12/2007
100000647251	Tom	Security	APR	WNTN7973A	NiMH	No	2100	1444	01/11/2008
100000647252	Tom	Security	APR	WNTN7973A	Li-Ion	Yes	1400	166	01/12/2007
100000647253	Tom	Security	APR	WNTN7973A	NiMH	No	2100	1444	01/11/2008
100000647254	Tom	Security	APR	WNTN7973A	Li-Ion	Yes	1400	166	01/12/2007
100000647255	Tom	Security	APR	WNTN7973A	NiMH	No	2100	1444	01/11/2008
100000647256	Tom	Security	APR	WNTN7973A	Li-Ion	Yes	1400	166	01/12/2007
100000647257	Tom	Security	APR	WNTN7973A	NiMH	No	2100	1444	01/11/2008
100000647258	Tom	Security	APR	WNTN7973A	Li-Ion	Yes	1400	166	01/12/2007
100000647259	Tom	Security	APR	WNTN7973A	NiMH	No	2100	1444	01/11/2008
100000647260	Tom	Security	APR	WNTN7973A	Li-Ion	Yes	1400	166	01/12/2007
100000647261	Tom	Security	APR	WNTN7973A	NiMH	No	2100	1444	01/11/2008
100000647262	Tom	Security	APR	WNTN7973A	Li-Ion	Yes	1400	166	01/12/2007
100000647263	Tom	Security	APR	WNTN7973A	NiMH	No	2100	1444	01/11/2008
100000647264	Tom	Security	APR	WNTN7973A	Li-Ion	Yes	1400	166	01/12/2007
100000647265	Tom	Security	APR	WNTN7973A	NiMH	No	2100	1444	01/11/2008
100000647266	Tom	Security	APR	WNTN7973A	Li-Ion	Yes	1400	166	01/12/2007
100000647267	Tom	Security	APR	WNTN7973A	NiMH	No	2100	1444	01/11/2008
100000647268	Tom	Security	APR	WNTN7973A	Li-Ion	Yes	1400	166	01/12/2007
100000647269	Tom	Security	APR	WNTN7973A	NiMH	No	2100	1444	01/11/2008
100000647270	Tom	Security	APR	WNTN7973A	Li-Ion	Yes	1400	166	01/12/2007
100000647271	Tom	Security	APR	WNTN7973A	NiMH	No	2100	1444	01/11/2008
100000647272	Tom	Security	APR	WNTN7973A	Li-Ion	Yes	1400	166	01/12/2007
100000647273	Tom	Security	APR	WNTN7973A	NiMH	No	2100	1444	01/11/2008
100000647274	Tom	Security	APR	WNTN7973A	Li-Ion	Yes	1400	166	01/12/2007
100000647275	Tom	Security	APR	WNTN7973A	NiMH	No	2100	1444	01/11/2008
100000647276	Tom	Security	APR	WNTN7973A	Li-Ion	Yes	1400	166	01/12/2007
100000647277	Tom	Security	APR	WNTN7973A	NiMH	No	2100	1444	01/11/2008
100000647278	Tom	Security	APR	WNTN7973A	Li-Ion	Yes	1400	166	01/12/2007
100000647279	Tom	Security	APR	WNTN7973A	NiMH	No	2100	1444	01/11/2008
100000647280	Tom	Security	APR	WNTN7973A	Li-Ion	Yes	1400	166	01/12/2007
100000647281	Tom	Security	APR	WNTN7973A	NiMH	No	2100	1444	01/11/2008
100000647282	Tom	Security	APR	WNTN7973A	Li-Ion	Yes	1400	166	01/12/2007
100000647283	Tom	Security	APR	WNTN7973A	NiMH	No	2100	1444	01/11/2008
100000647284	Tom	Security	APR	WNTN7973A	Li-Ion	Yes	1400	166	01/12/2007
100000647285	Tom	Security	APR	WNTN7973A	NiMH	No	2100	1444	01/11/2008
100000647286	Tom	Security	APR	WNTN7973A	Li-Ion	Yes	1400	166	01/12/2007
100000647287	Tom	Security	APR	WNTN7973A	NiMH	No	2100	1444	01/11/2008
100000647288	Tom	Security	APR	WNTN7973A	Li-Ion	Yes	1400	166	01/12/2007
100000647289	Tom	Security	APR	WNTN7973A	NiMH	No	2100	1444	01/11/2008
100000647290	Tom	Security	APR	WNTN7973A	Li-Ion	Yes	1400	166	01/12/2007
100000647291	Tom	Security	APR	WNTN7973A	NiMH	No	2100	1444	01/11/2008
100000647292	Tom	Security	APR	WNTN7973A	Li-Ion	Yes	1400	166	01/12/2007
100000647293	Tom	Security	APR	WNTN7973A	NiMH	No	2100	1444	01/11/2008
100000647294	Tom	Security	APR	WNTN7973A	Li-Ion	Yes	1400	166	01/12/2007
100000647295	Tom	Security	APR	WNTN7973A	NiMH	No	2100	1444	01/11/2008
100000647296	Tom	Security	APR	WNTN7973A	Li-Ion	Yes	1400	166	01/12/2007
100000647297	Tom	Security	APR	WNTN7973A	NiMH	No	2100	1444	01/11/2008
100000647298	Tom	Security	APR	WNTN7973A	Li-Ion	Yes	1400	166	01/12/2007
100000647299	Tom	Security	APR	WNTN7973A	NiMH	No	2100	1444	01/11/2008
100000647300	Tom	Security	APR	WNTN7973A	Li-Ion	Yes	1400	166	01/12/2007

Рис. 29: Звіт про акумулятори, які використовуються зараз



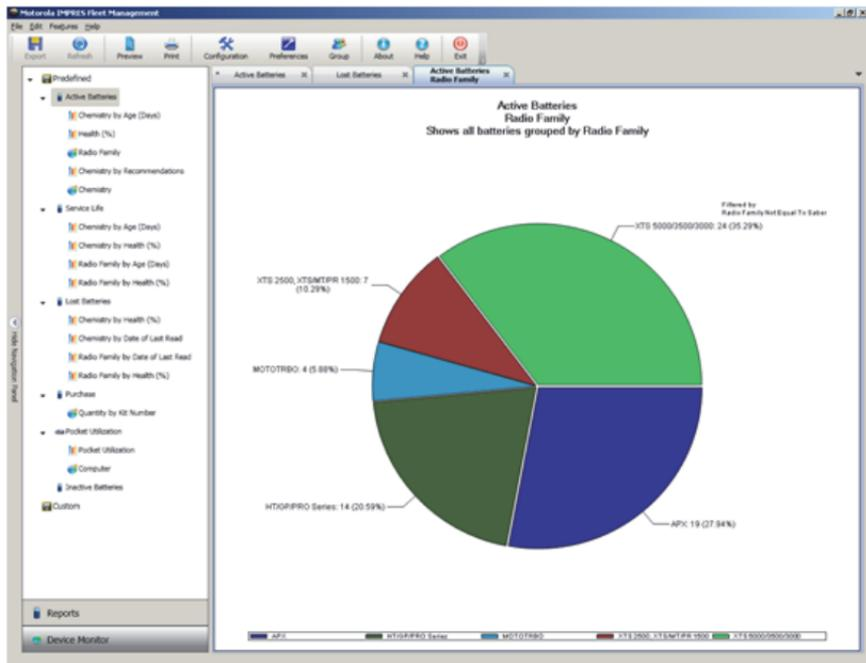

**Рис. 30:** Акумулятори, які використовуються сімейством радіостанцій





Рис. 32: Використання гнізд зарядного пристрою

## Настінний кронштейн для багатомісного зарядного пристрою

Для цього багатомісного зарядного пристрою доступний настінний кронштейн (номер компонента: 0705559L01). Для замовлення зверніться до місцевого дилера. Порядок установки показано нижче.

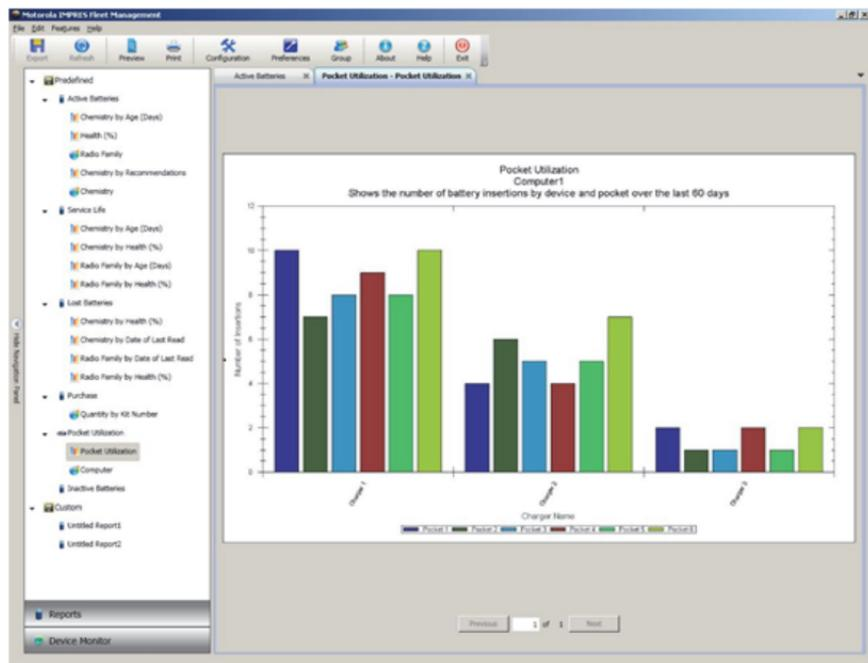

ПОПЕРЕДЖЕННЯ

- Закріплювати кронштейн на стіні має лише кваліфікований спеціаліст. Недотримання цієї вимоги становить велику небезпеку та може спричинити травмування або пошкодження майна.
- Не закріплюйте кронштейн на стіні, що не витримає його вагу з зарядним пристроєм. Якщо стіні, на якій кріпиться кронштейн, бракує міцності, кронштейн може впасти та спричинити травми.
- Не кріпите кронштейн на стіні, що може зазнати впливу вібрації або механічних ударів.



Рис. 33: Кріпильні отвори й розташування фіксаторів

## Кріплення багатомісного зарядного пристрою на настінному кронштейні

1. Розмістіть настінний кронштейн у потрібному місці та позначте на поверхні стіни місця, де мають розташовуватися монтажні отвори.

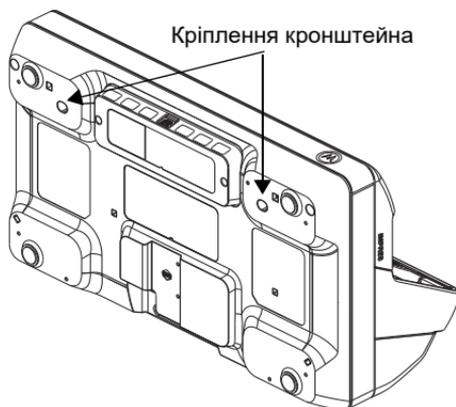
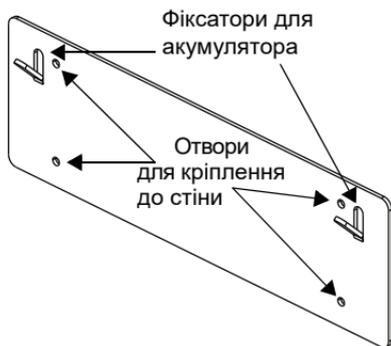

Застереження

Перш ніж виконувати різання, свердління чи вкручувати монтажні гвинти, переконайтеся, що в місці кріплення в стіні не проходять електричні дроти, кабелі або труби.

2. Закріпіть кронштейн на стіні за допомогою кріпильного обладнання відповідно до матеріалу стіни. Просвердліть у стіні отвори в позначених місцях.
3. Закріпіть кронштейн, вставивши гвинти в монтажні отвори та надійно закрутивши їх.

**Примітка.** У разі кріплення кронштейна на дерев'яному стояку каркаса або бетонній чи цегляній поверхні рекомендовано використовувати самонарізні гвинти завдовжки приблизно 40 мм (1,5 дюйма) з різьбою М10–М16 і шайби відповідного розміру (не входять до комплекту).

4. Розмістіть багатомісний зарядний пристрій на настінному кронштейні.

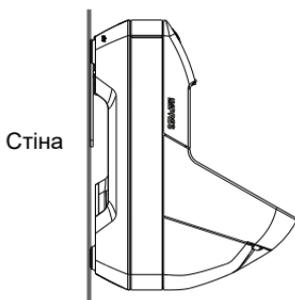

**Рис. 34:** Зарядний пристрій, закріплений у настінному кронштейні

# Notes



**EU Contact:**

Motorola Solutions, Czerwone Maki 82,  
30-392 Krakow, Poland

**Контактна інформація:**

Моторола Солюшинс Системз Польща  
вул. Червоне Маки, 82,  
30-392 Краків,  
Польща

MOTOROLA, MOTO, MOTOROLA SOLUTIONS and the Stylized M logo are trademarks or registered trademarks of Motorola Trademark Holdings, LLC and are used under license. All other trademarks are the property of their respective owners.

© 2016 and 2022 Motorola Solutions, Inc. All rights reserved.

**MN002407A01-AH**